

AQUAIRS-25

of Water to Air Space Heaters



**INSTALLATION, COMMISSIONING
& SERVICING INSTRUCTIONS**

Aquair S-25

These instructions are to be left with the User



**Johnson
& Starley**



Johnson & Starley Ltd
Rhosili Road
Brackmills, Northampton
NN4 7LZ

CONTENTS

1	Features	3
2	General Description	3
3	Building Standards & Regulations	4
4	Safety Information <i>Handling the Unit</i> <i>Electrical Supply</i>	4
5	Technical Data	4
6	Positioning & Preparation	5
7	Installation Instructions <i>Downflow Installation</i> <i>Water Connections</i> <i>Electrical Harness</i>	5
8	Return Air System	5
9	Electrical	6
10	Circuit Diagram	6
11	Fan Performance	6
12	Operating Mode <i>High Temperature Mode</i> <i>Low Temperature Mode</i>	7
13	Commissioning <i>Setting Maximum Speed</i> <i>Setting Minimum Speed</i> <i>With Therimsta-stat Fitted</i> <i>With No Thermista-stat Fitted</i>	7
14	Servicing & Maintenance <i>Routine Maintenance</i> <i>PCB Replacement</i> <i>PCB Removal</i> <i>Fan Removal</i> <i>Heat Exchanger Removal</i> <i>Air Filter Removal</i>	7
15	Faulty Finding	8
16	Dimensions	10
17	Spares List	10
18	Exploded Diagram	11

In the interest of continuous development Johnson and Starley reserve the right to change specification without prior notice.
Johnson and Starley prides itself on it's ability to supply spare parts quickly and efficiently.

1. FEATURES

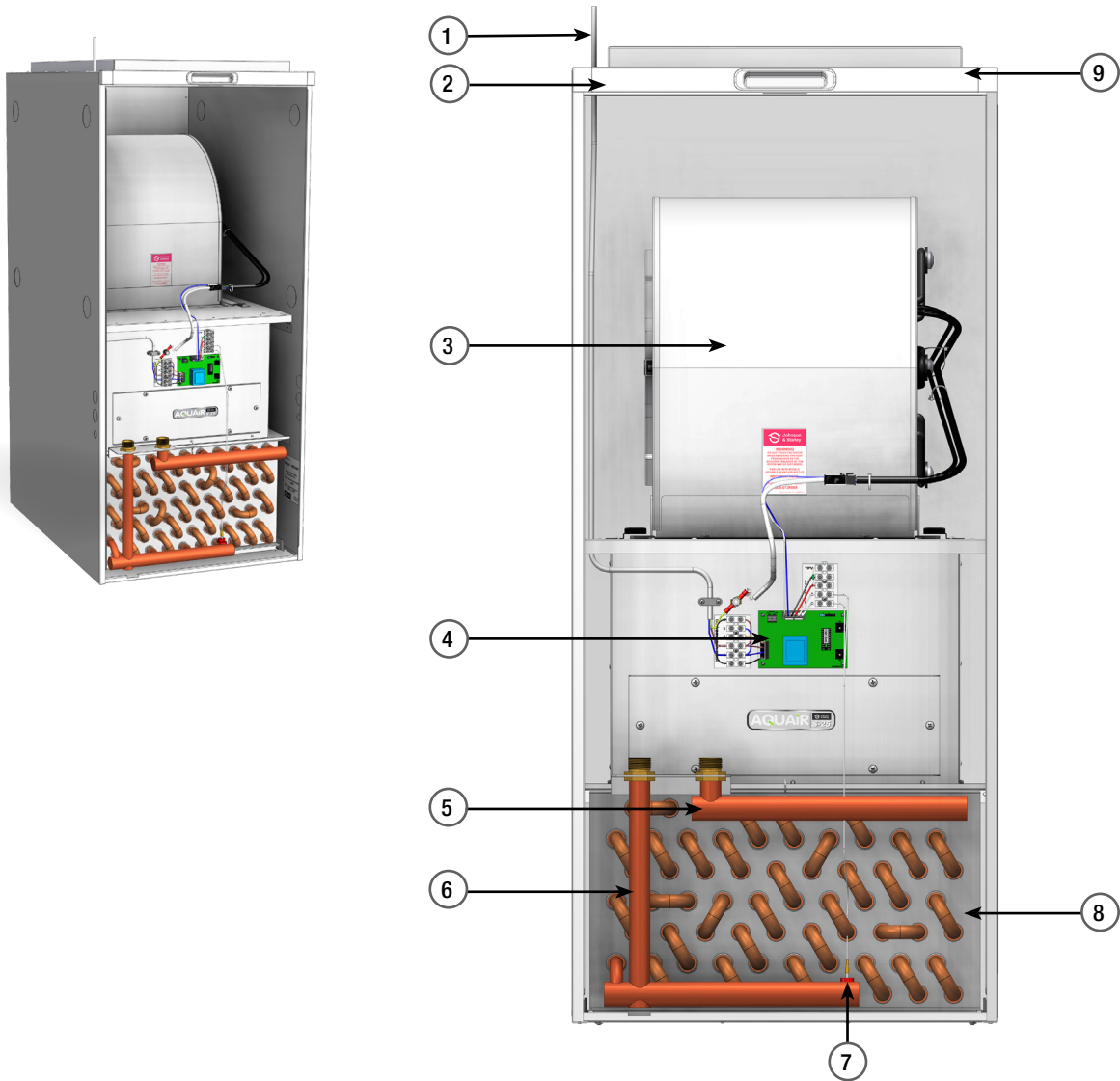

FIGURE 1. AQUAIR S-25 FEATURES

1	Mains Supply
2	Air Filter
3	Air Circulation Fan with EC Technology
4	PCB Control Board

5	Hot water return to heat source
6	Hot water flow from heat source
7	Flow Sensor
8	Heat Exchanger
9	Spigot Frame

2. GENERAL DESCRIPTION

- 2.1 AQUAIR S is a water to air heat exchange unit with a heat output of 25kW (assuming a hot water supply at 80°C is available). Modairflow control is incorporated. A wire mesh filter is fitted as standard. The unit requires a supply of hot water at a minimum temperature of 60°C. Water connections are left or right handed through knockouts in the sides of the cabinet.
- 2.2 The air is drawn in through the air filter or Cleanflow air cleaner (if fitted) and the heat exchanger by a centrifugal fan, and is discharged through the opposite end of the unit. A Summer Air Circulation switch (optional) provides the facility to supply unheated air to the air outlets during warm weather. An external timer (not provided) will be required if it is necessary to set the periods of operation.
- 2.3 The Aquair S Unit has been designed to allow downflow configuration only.

3. BUILDING STANDARDS & REGULATIONS

NOTE: Installation shall be in accordance with the following

- **Building Standards (Scotland) (Consolidation) Regulations**
- **Building Regulations Part L**
- **The Water Fittings Regulations or Water byelaws in Scotland**
- **Model and Local Authority Byelaws**
- **BS 5720** Mechanical Ventilation and Air Conditioning in Buildings
- **BS 7671** Institute of Electrical Engineers (I.E.E) Wiring Regulations
- **Health & Safety Document No. 635.**
- **The Electricity at Work Regulations, 1989.**

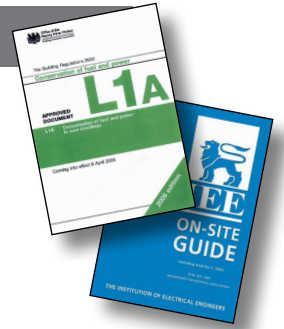

IMPORTANT: This appliance is CE certificated for safety and performance. It is important that no modifications are made to this appliance, unless fully approved in writing by Johnson & Starley Ltd.

If in doubt please Ring Johnson & Starley Ltd on Telephone: 01604 762881.

* The manufacturers instructions supplied must not be taken as overriding any statutory requirements.

4. SAFETY INFORMATION

4.2 HANDLING THE UNIT

- 4.2.1 The weight of the this appliance exceeds that recommended for a one-man lift. It will therefore be necessary to gain assistance at times during the removal from its packaging and during installation procedure. Manoeuvring the boiler may include the use of a sack truck and involve lifting, pushing and pulling.
- 4.2.2 It should be noted that this appliance may contain sharp edges. Care **MUST** be taken when handling the appliance to prevent injury. We advise the engineer to wear suitable P.P.E.
- 4.2.3 Once the appliance has been fired beware that certain parts will be hot to the touch.
- 4.2.4 Do not install flues during rain, high winds or in severe weather conditions.

4.1 ELECTRICAL SUPPLY

- 4.1.1 Ensure the mains supply voltage, frequency, number of phases and power rating comply with details on the rating label.
- 4.1.2 All wiring must be in accordance with the appropriate standards.
- 4.1.3 Ensure safety regulations and practices are adhered to when installing and using this appliance.

5. TECHNICAL DATA

TABLE 1	ITEM		S-25
	Nominal Rated Output	kW	25
	Air on Temperature	°C	20
	Air off Temperature	°C	67
	Water Supply Temperature	°C	80
	Water Return Temperature	°C	55
	Water Flow Rate	l/s	0.25
	Air Volume	m ³ /h	1584
	Water Connections	bsp	¾
	Maximum Water Pressure	Bar	3
	Maximum Power Consumption	W	530W
	Dimensions mm	H/W/D	1078 x 480 x 710
	Return Air Frame	mm	587 x 400
	Electrical Supply	A	230V, 50Hz, fuse rated at 3A
	Weight	kg	70kg

6. POSITIONING & PREPARATION

- 6.1 The unit should be positioned to suit any duct work. Mount on a plenum, if necessary or frame strong enough to hold the unit, avoiding any strain being placed on associated pipe and duct work.
- 6.2 Once the position of the unit has been decided, make sure all extra ancillaries are installed ready for the units installation. A list of the ancillaries is available by contacting Johnson & Starley Ltd, Tel: 01604 762881.
- 6.3 Make sure all the electrical cables are in place.
- 6.4 It is important that the system is flushed thoroughly prior to installation. Failure to do so could result in the appliance a blockage and cause damage to the system and reduce the efficiency. This MUST to comply with the water treatment guidelines.
- IMPORTANT: It is recommended that the water system be drained and flushed prior to the installation of the unit. A strainer must be fitted upstream of the unit.**
- 6.5 Clearance of 750mm is required at the front of the casing for servicing and replacement of the heat exchanger. It is recommended that provision be made for complete removal of the unit.
- 6.6 Sufficient clearance must be provided for the assembly of ducting and pipework.

7. INSTALLATION INSTRUCTIONS

- 7.1 The Aquair S-25 appliance exceed the recommended weight for a one-man lift as detailed in the Manual Handling Operations,1992 Regulations.
- 7.2 The once the unit has been unpacked unscrew the transit plate from the base of the unit and discard.

NOTE: This unit could contain sharp edges and care MUST be taken when handling.

7.3 DOWNFLOW INSTALLATION *See Figure 2*

- 7.3.1 Remove the filter cover to expose the two screw holding the door in place. Remove the screws and gently pull and lift the door off the unit.
- 7.3.2 Lift the appliance onto the plenum or base support and position correctly. Seal the joint with the appropriate sealing material.
- 7.3.3 The water connections to the unit should be by compression fittings that are suitable for the duty and isolation valves must be fitted to facilitate the removal of the heat exchanger assembly.
- 7.3.4 If a return air duct is not to be fitted, the top of the unit must be suitably guarded to prevent any blockage.

7.4 WATER CONNECTIONS

The water connections to the unit should be compression type fittings that are suitable for the duty of the appliance. Isolation valves must **be fitted to facilitate the removal of the heat exchanger assembly.**

NOTE: Care must be taken with the heat exchanger matrix is fragile and is easily damaged.

7.5 ELECTRICAL HARNESS

Re-route the harness cable through the side knockout. Using the grommet attached, to seal the hole.

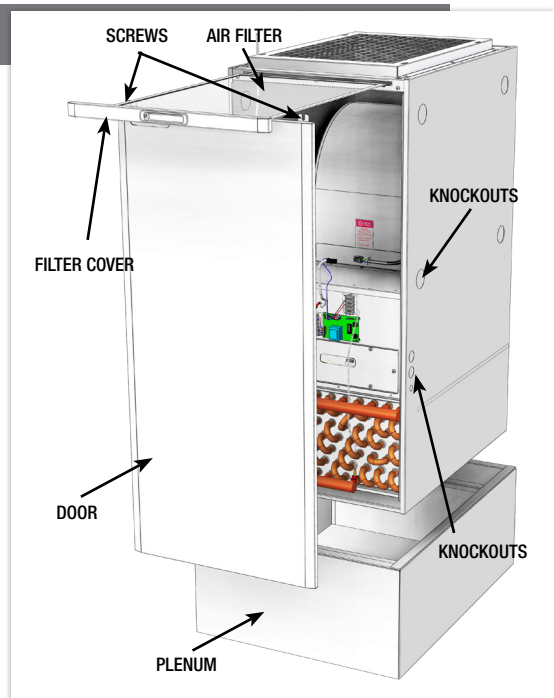

FIGURE 2. DOWNFLOW CONFIGURATION

8. RETURN AIR SYSTEM

- 8.1 The return air system should be constructed of fire-resistant material. It is important that the correct size of return air grilles and ducting is used. Refer to table below for return air duct size, flexible duct size and the return air grille size at maximum output.

TABLE 2	DUCT EQUIVALENT SIZE	FLEXIBLE DUCT SIZE	RETURN AIR GRILLE
S-25	600 x 400mm (23" x 16")	508mm (20") dia	4200cm ² (in ²)

- 8.2 An adequate and unobstructed return air path is required from areas not served by a directly ducted return and to which warm air is delivered. All such rooms should be fitted with relief grilles which have a free area of 0.0088m²/kW (1in²/250Btu/h) of heat supplied to the room. The only exceptions are kitchens, bathrooms and WC.'s.

9. ELECTRICAL

- 9.1 The appliance is supplied with PVC sheathed, 3 core 0.75mm² csa rated at 6A, connected to a terminal block and exiting through the casing at the top left hand front. The cable is suitable for a 230V 50Hz single phase supply.
- 9.2 The means of isolating the appliance MUST be via a double pole switch with a contact separation of at least 3mm in both poles, and fused at 3A. If switched live is fitted, a triple pole switch should be used.

10. CIRCUIT DIAGRAM

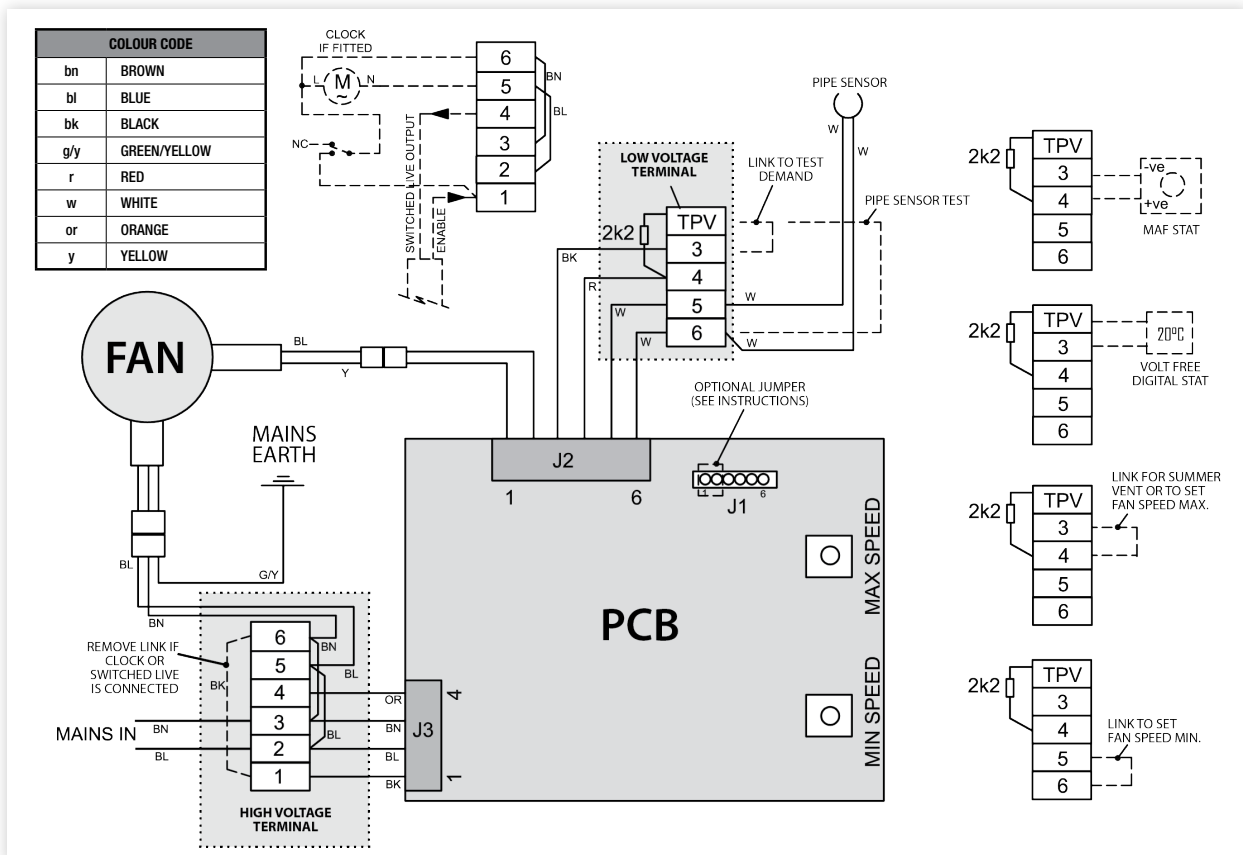

FIGURE 4. AQUAIR S-25 CIRCUIT DIAGRAM

11. FAN PERFORMANCE

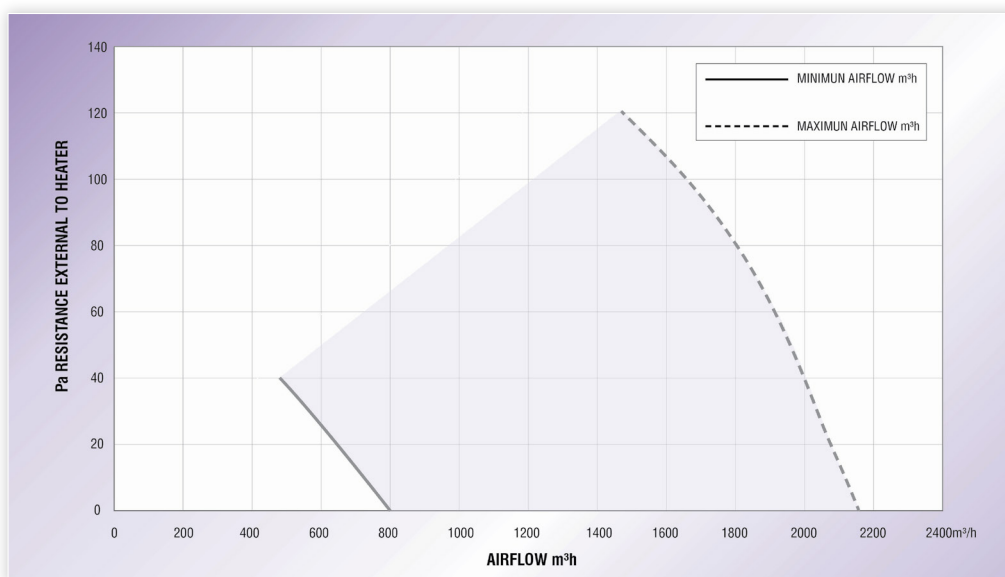

FIGURE 3. FAN PERFORMANCE GRAPH

12. OPERATING MODES

12.1 HIGH TEMPERATURE MODE

- 12.1.1 For high temperature mode the J1 pins 1 + 2 has NO jumper.
- 12.1.2 With a thermista-stat connected (see note*), the fan will run when a water temperature of 60°C is reached and stops when the water temperature falls to 42°C. The fan speed is controlled by the thermista-stat demand.
- 12.1.3 With no thermista-stat connected, the fan will run when a water temperature of 44°C is reached, the fan speed is controlled by the water temperature. The maximum fan speed reached when the water temperature is at 60°C.

12.2 LOW TEMPERATURE MODE

- 12.2.1 For low temperature mode J1 has a jumper across pins 1 + 2.
- 12.2.2 With the thermista-stat connected, the fan will run when a water temperature of 33°C is reached and stops when the water temperature falls to 20°C. The fan speed is controlled by the thermista-stat demand.
- 12.2.3 With no thermista-stat connected, the fan will run when a water temperature of 22°C is reached, the fan speed is controlled by the water temperature. The maximum fan speed reached when the water temperature is at 32°C.

NOTE: Thermista-stat to be ordered separately.

13. COMMISSIONING

- 13.1 Ensure the heater is correctly fitted with water and all air vented from the flow and return circuits.
- 13.2 Switch on electrical supply.
- 13.3 **Setting maximum speed.**
Make a short across thermista-stat connections, if fitted, and adjust the fan speed as required, remove the short.
- 13.4 **Setting minimum fan speed.**
Make a short across the pipe sensor and adjusted the fan speed as required, remove short.
- 13.5 **WITH THERMISTA-STAT FITTED**
 - 13.5.1 Turn up thermista-stat to call for heat.
 - 13.5.2 Check for 230V on switch live out.
 - 13.5.3 With the water at the required temperature ensure fan starts
 - 13.5.4 Allow the system to warm up and check temperature rise across unit is 40°C.
 - 13.5.5 Set water differential to 20°C using lock shield valve or equivalent.
 - 13.5.6 Turn off thermista-stat and check there is NO 230V on switch live out.
 - 13.5.7 Check fan stops when water cools to required temperature.
- 13.6 **WITH NO THERMISTA-STAT FITTED**
 - 13.6.1 With the water at the required temperature ensure fan starts.
 - 13.6.2 Allow the system to warm up and check temperature rise across unit is 40°C.
 - 13.6.3 Set water differential to 20°C using lockshield valve or equivalent.
 - 13.6.4 Check fan stops when water cools to required temperature.

14. SERVICING & MAINTENANCE

14.1 ROUTINE MAINTENANCE

IMPORTANT: Before carrying out any work on the unit, ALWAYS ENSURE THAT IT IS ISOLATED FROM THE MAINS ELECTRICAL SUPPLY.

Remove the filter and unscrew the two retaining screws holding the front cover on the unit, gently pull it forward. Maintenance should be carried out at least once per year.

- 14.1.1 Check that the heat exchanger airways are free from obstructions. If necessary, clean with a vacuum cleaner from the air inspection panel, taking care to not damage the airways.

CAUTION: THE ELEMENTS OF THE HEAT EXCHANGER ARE VERY FRAGILE.

- 14.1.2 Check the condition of the external strainer, cleaning as necessary.
- 14.1.3 Check that the air filter is being regularly cleaned in accordance with the User's Instructions.

14.2 PCB REPLACEMENT

Ensure that the electrical supply is switched off and isolated.

14.3 PCB REMOVAL

- 14.3.1 Disconnect the wiring at the PCB terminal block.
- 14.3.2 Release the 4 clips securing the PCB and withdraw the panel, disconnecting the fan supply lead at the fan tray terminal block.
- 14.3.3 Reassembly or replacement is in reverse order.

14.4 FAN REMOVAL

- 14.4.1 Ensure that the electrical supply is switched off and isolated.
- 14.4.2 Disconnect the 2 inline connectors on the fan assembly.
- 14.4.3 Release the screws securing the fan and withdraw it from the location runners.
- 14.4.4 Refitment or replacement is in reverse order.

14.5 HEAT EXCHANGER REMOVAL

- 14.5.1 Ensure that the electrical supply is switched off and isolated.
- 14.5.2 Close the isolating valves and drain down the unit.
- 14.5.3 Release the clip and remove the heat exchanger and its associated pipework from the unit.
- 14.5.4 Refitment or replacement is in reverse order. Ensure that all air locks are expelled, and check for water soundness.

14.6 AIR FILTER REMOVAL

- 14.6.1 Remove the filter cover.
- 14.6.2 Remove the two air filters out by sliding it from the front of the unit.

15. FAULT FINDING

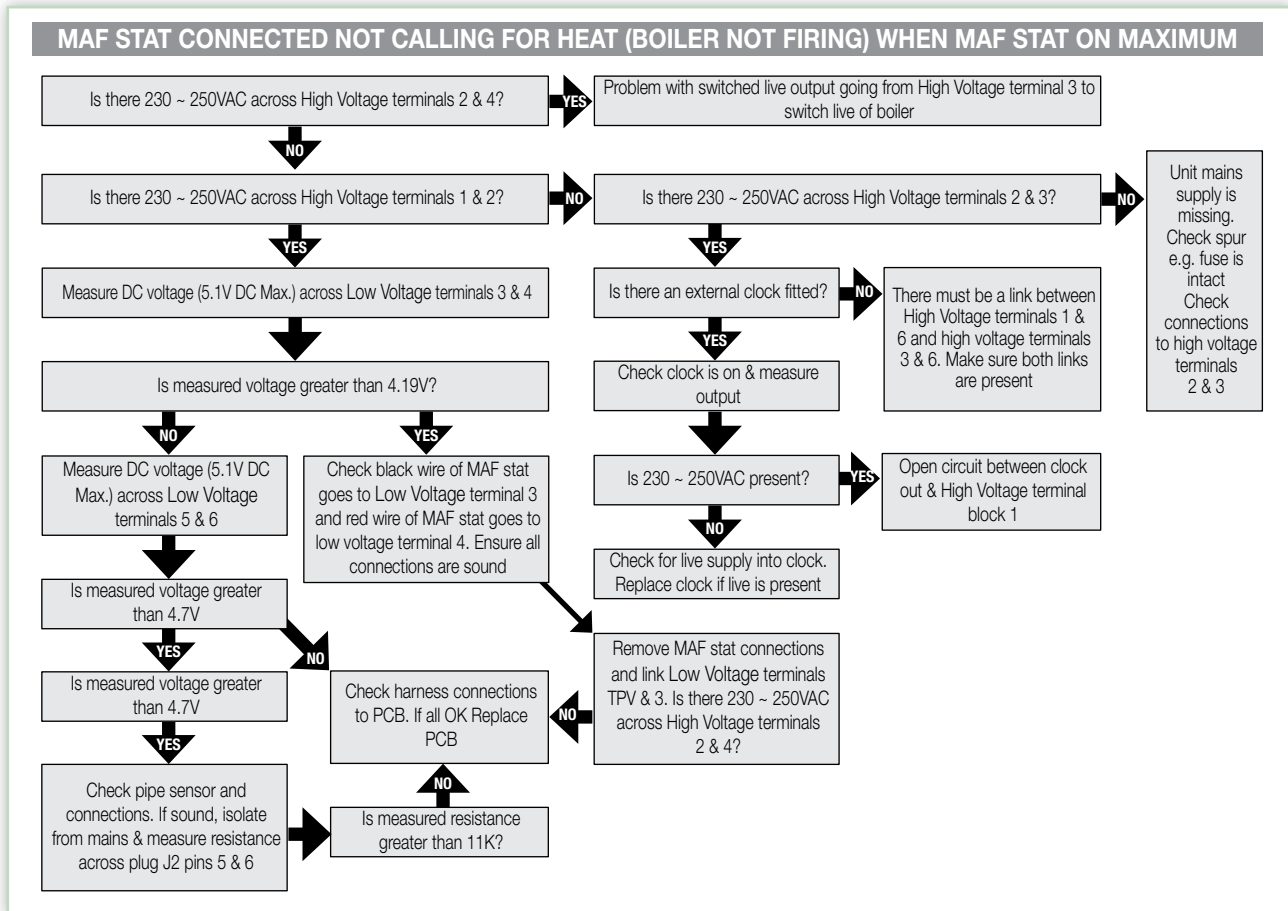

FAN NOT OPERATING WHEN PIPE IS ABOVE 60°C

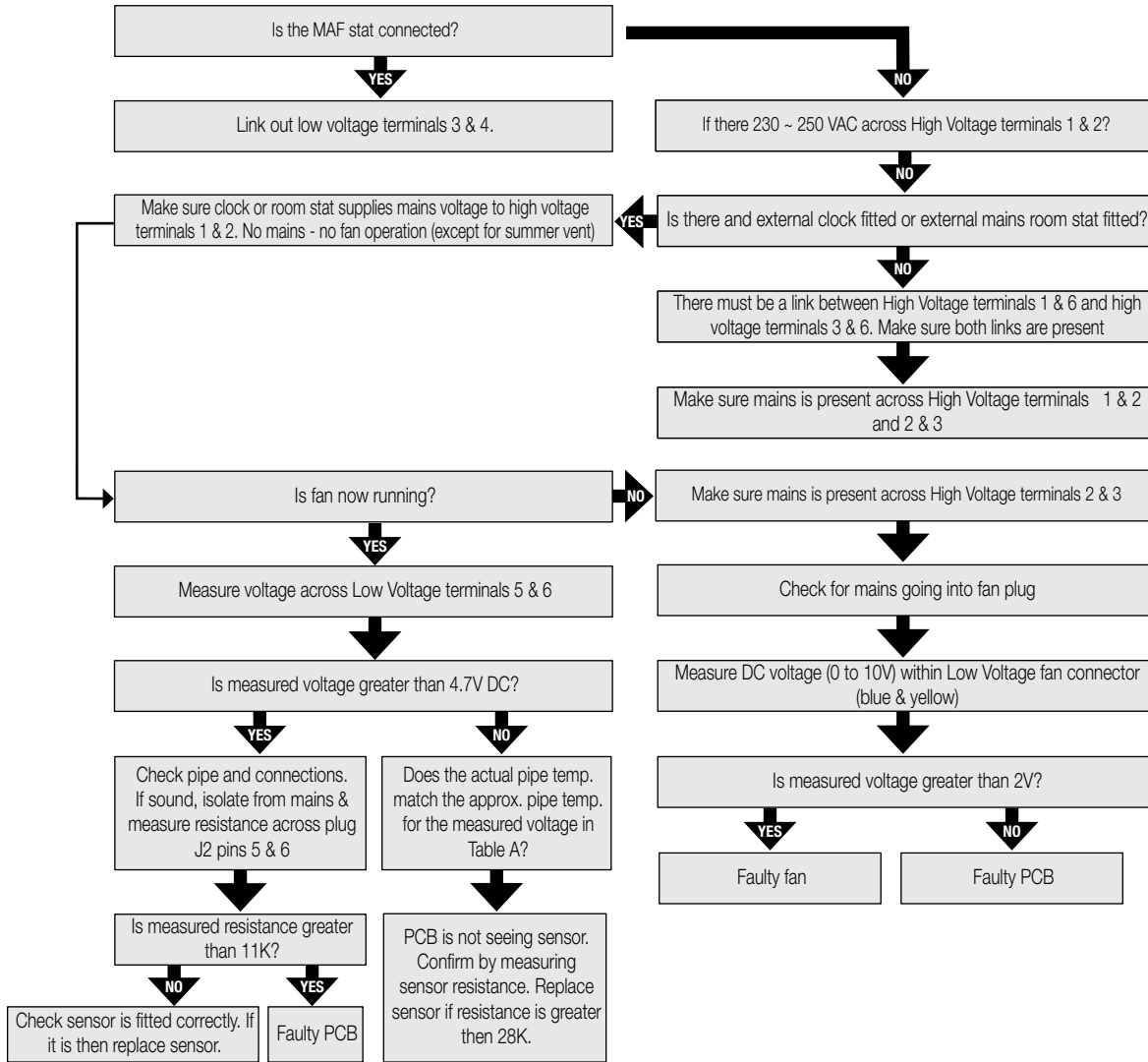

DC VOLTAGE ACROSS PIPE SENSOR	APPROX. PIPE TEMP. °C	DC VOLTAGE ACROSS PIPE SENSOR	APPROX. PIPE TEMP. °C	DC VOLTAGE ACROSS PIPE SENSOR	APPROX. PIPE TEMP. °C	DC VOLTAGE ACROSS PIPE SENSOR	APPROX. PIPE TEMP. °C
3.24	10	2.13	33	1.26	56	0.73	79
3.19	11	2.08	34	1.23	57	0.71	80
3.14	12	2.04	35	1.20	58	0.70	81
3.09	13	1.99	36	1.17	59	0.68	82
3.04	14	1.95	37	1.15	60	0.66	83
2.99	15	1.91	38	1.12	61	0.65	84
2.94	16	1.87	39	1.09	62	0.63	85
2.89	17	1.83	40	1.07	63	0.63	86
2.84	18	1.79	41	1.04	64	0.60	87
2.79	19	1.75	42	1.02	65	0.59	88
2.75	20	1.71	43	0.99	66	0.58	89
2.70	21	1.67	44	0.97	67	0.56	90
2.65	22	1.63	45	0.95	68	0.55	91
2.60	23	1.59	46	0.92	69	0.54	92
2.55	24	1.56	47	0.90	70	0.53	93
2.50	25	1.52	48	0.88	71	0.51	94
2.45	26	1.49	49	0.86	72	0.50	95
2.40	27	1.45	50	0.84	73	0.49	96
2.36	28	1.42	51	0.82	74	0.48	97
2.31	29	1.39	52	0.80	75	0.47	98
2.26	30	1.35	53	0.78	76	0.46	99
2.22	31	1.32	54	0.76	77	0.45	100
2.17	32	1.29	55	0.75	78		

TABLE A

16. DIMENSIONS

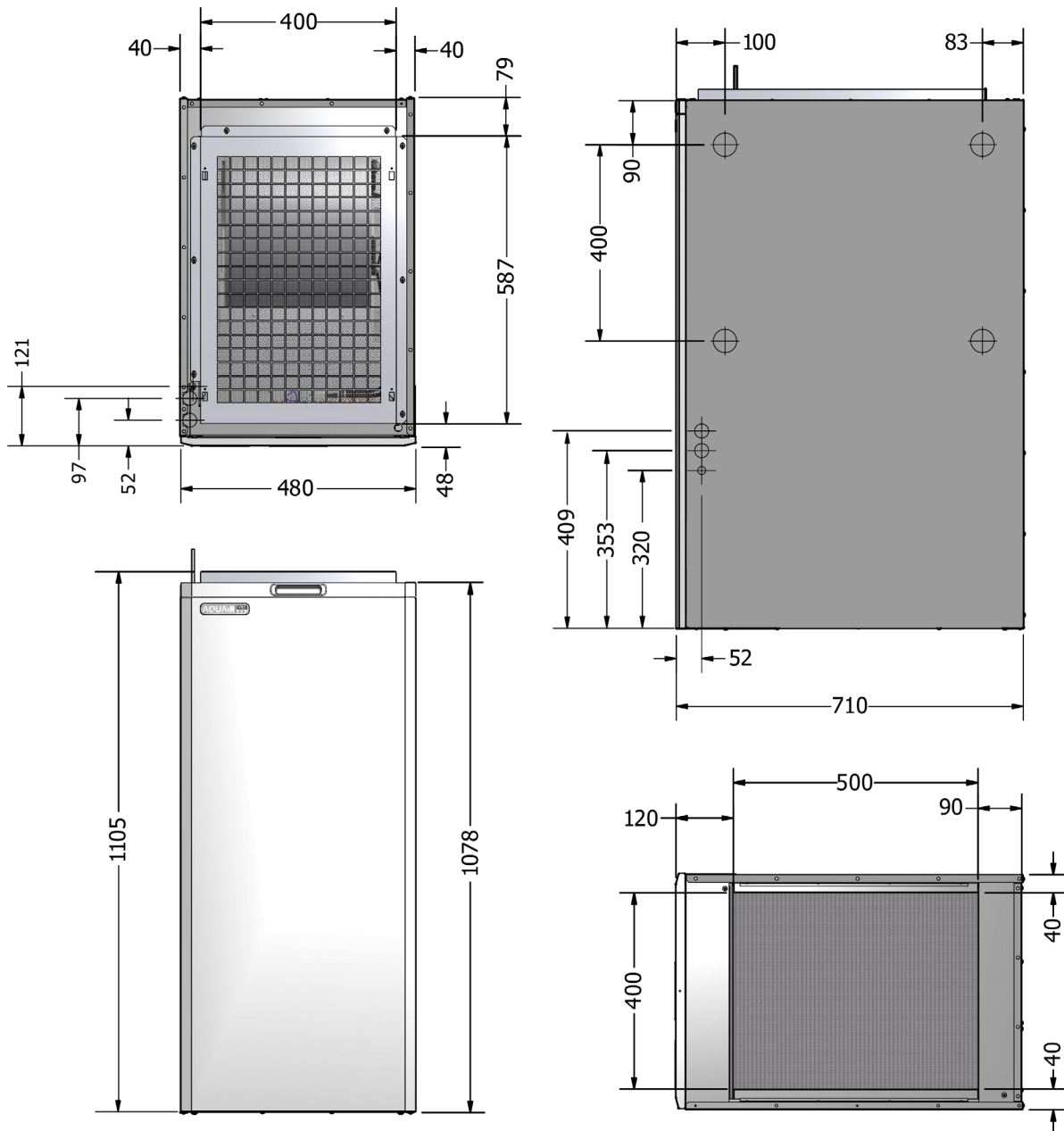

FIGURE 7. AQUAIR S-25 DIMENSIONS

17. SPARES LIST

ITEM	DESCRIPTION	QTY	S-25
1	Air filter	2	AQ25-0185005
2	Air circulation fan with EC technology	1	1000-0525980
3	PCB control board	1	1000-0526275
4	Temperature flow sensor	1	1000-0526505
5	Front Cover	1	AQ25-0199005
6	Heat exchanger	1	AQ25-0138005
7	Thermista-stat (<i>not shown</i>)	1	BOS01242

18. EXPLODED DIAGRAM

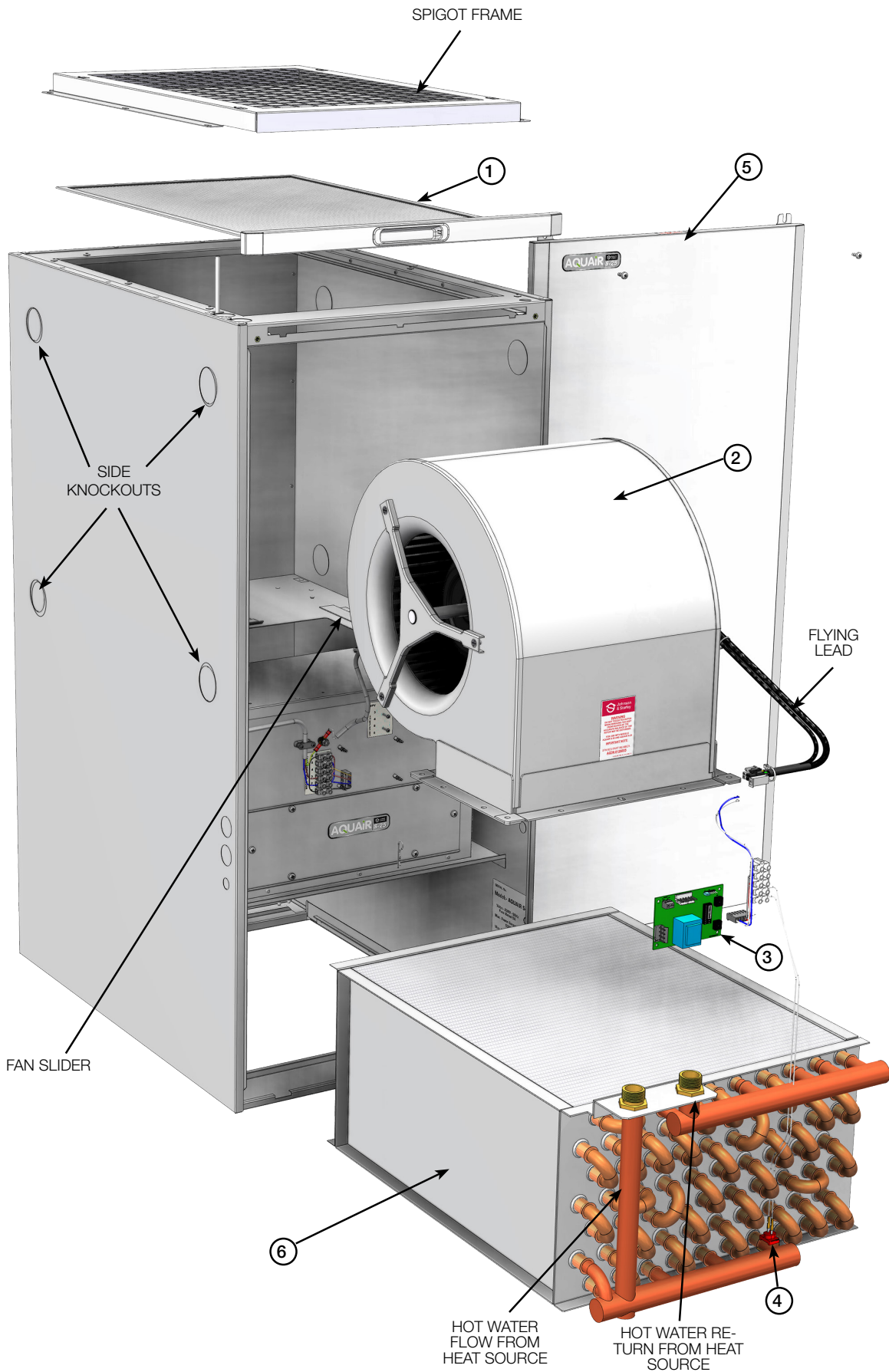

FIGURE 8. AQUAIR S-25 EXPLODED DIAGRAM



Johnson & Starley Ltd
Rhosili Road, Brackmills,
Northampton NN4 7LZ

sales@johnsonandstarley.co.uk
customer.service@johnsonandstarley.co.uk
service@johnsonandstarley.co.uk
marketing@johnsonandstarley.co.uk

Reception/Customer Service
01604 762881

