



sustainable solutions **under one roof**

HEATING / HOT WATER / VENTILATION

Publication No. ZZ 1410-4
December 2016

WARMCAIR C46D

Condensing Air Heater

High Efficiency Downflow
Condensing Air Heater



INSTALLATION, COMMISSIONING
& SERVICING INSTRUCTIONS

WarmCair C46D - G.C. No. 42-415-21

These instructions are to be left with the User



www.johnsonandstarley.co.uk

CONTENTS

The Benchmark Scheme	2	15	Handing Over	17
1 Features	3	16	Servicing & Maintenance	18
2 General Description	3		<i>Servicing Schedule</i>	
3 Building Standards & Regulations	4		<i>Servicing Sequence</i>	
4 Safety & Gas Information	5		<i>Component Checklist</i>	
<i>General Safety Information</i>			<i>Gaining Access for Servicing</i>	
<i>Gas Categories</i>			<i>Main Burner Assembly</i>	
<i>Gas Supply</i>			<i>Ignition & Flame Detection Electrode</i>	
5 Technical Data	5		<i>Heat Exchanger/Combustion Chamber</i>	
6 Heater Positioning	6		<i>Combustion Air Fan</i>	
7 Heater Compartment Clearances	6		<i>Air Circulations Fan</i>	
8 Duct System	7		<i>Condensate Drain Piped</i>	
<i>Return Air</i>			<i>Condensate Pump</i>	
<i>Warm Air Delivered</i>		17	Parts Replacements	22
9 Flue Instructions	8		<i>Control Panel</i>	
<i>Flue Configuration</i>			<i>Air Circulation Fan</i>	
<i>Diagram of Terminal Position</i>			<i>Return Air Temperature Sensor</i>	
<i>Types of Flue Systems</i>			<i>Flue Temperature Sensor</i>	
<i>Flue Terminal Positions</i>			<i>High Limit Temperature Sensor</i>	
<i>Plume Terminal Outlets</i>			<i>Air Pressure Switch</i>	
<i>Flue Requirements & General Information</i>			<i>Condensate Drain Pump</i>	
<i>Conventional 60/100mm Flue Accessories Part No.s</i>			<i>Main Ignition/Control PCB</i>	
<i>Optional Roof Outlets</i>			<i>Gas Valve & Venturi Assembly</i>	
<i>The Extended Horizontal Flue System</i>			<i>Burner Assembly</i>	
11 Condensate Pump & Drain Tube	13		<i>Ignition Electrodes</i>	
<i>Condensate Pump</i>			<i>Flame Detections Electrodes</i>	
<i>Technical Data</i>			<i>Combustion Air Fan</i>	
<i>Condensate Tube Routing Options</i>		18	Control Panel Modes	25
11 Gas	14	19	Fault Code & Blocking Code Table	26
12 Electrical	14	20	Fault Finding Flowcharts	27
<i>Mains Supply</i>		21	Defect Diagnosis for the Circulation Air Fan	29
<i>Thermista-stat & Its Location</i>		22	Functional Wiring Diagrams	30
13 Fitting Instructions	15	23	Dimensions	32
14 Commissioning	15	24	List of Spares	33
<i>System Balancing</i>		26	Ancillaries	36
<i>Lighting the Main Burner</i>		27	Code of Practice	37
<i>Gas Rate Check</i>		28	Benchmark Checklist and Service Record	48



PLEASE READ THESE INSTRUCTIONS CAREFULLY BEFORE STARTING INSTALLATION. LEAVE THESE INSTRUCTION WITH THE USER OR AT THE GAS METER AFTER INSTALLATION

The Benchmark Scheme

Benchmark places responsibilities on both manufacturers and installers. The purpose is to ensure that customers are provided with the correct equipment for their needs, that it is installed, commissioned and serviced in accordance with the manufacturer's instructions by competent persons and that it meets the requirements of the appropriate Building Regulations. The Benchmark Checklist can be used to demonstrate compliance with Building Regulations and should be provided to the customer for future reference.

Installers are required to carry out installation, commissioning and servicing work in accordance with the Benchmark Code of Practice which is available from the Heating and Hotwater Industry Council who manage and promote the Scheme.

Visit www.centralheating.co.uk for more information.

In the interest of continuous development Johnson and Starley reserve the right to change specification without prior notice. Johnson and Starley prides itself on it's ability to supply spare parts quickly and efficiently.

1. FEATURES

Appliance Classification:

The WarmCair C46D has been tested and CE certified by B.S.I Ltd for use with NATURAL gas G20.

FEATURES

1. 60/100mm to 80/125mm Adapter
2. 60/100mm Flue Turret
3. Combustion Measuring Point
4. Time Control
5. PCB Control Wiring Panel
6. Sliding Flue Connector
7. Flue Collector Box
8. Flue Sensor
9. Condense Outlet
10. Inspection Glass
11. Condense Trap Assembly
12. Condensing Pump Outlet Pipe Hose
13. Condense Pump
14. Duct Temperature Sensor
15. Gas Cock
16. ESYS
17. Gas Valve
18. Ignition & Detection Electrodes
19. High Limit Temperature Sensor
20. Combustion Air fan Assembly
21. Return Air Sensor
22. Fan Failure Sensor
23. Air Circulation Fan
24. MMI Control Panel
25. Return Air Filter

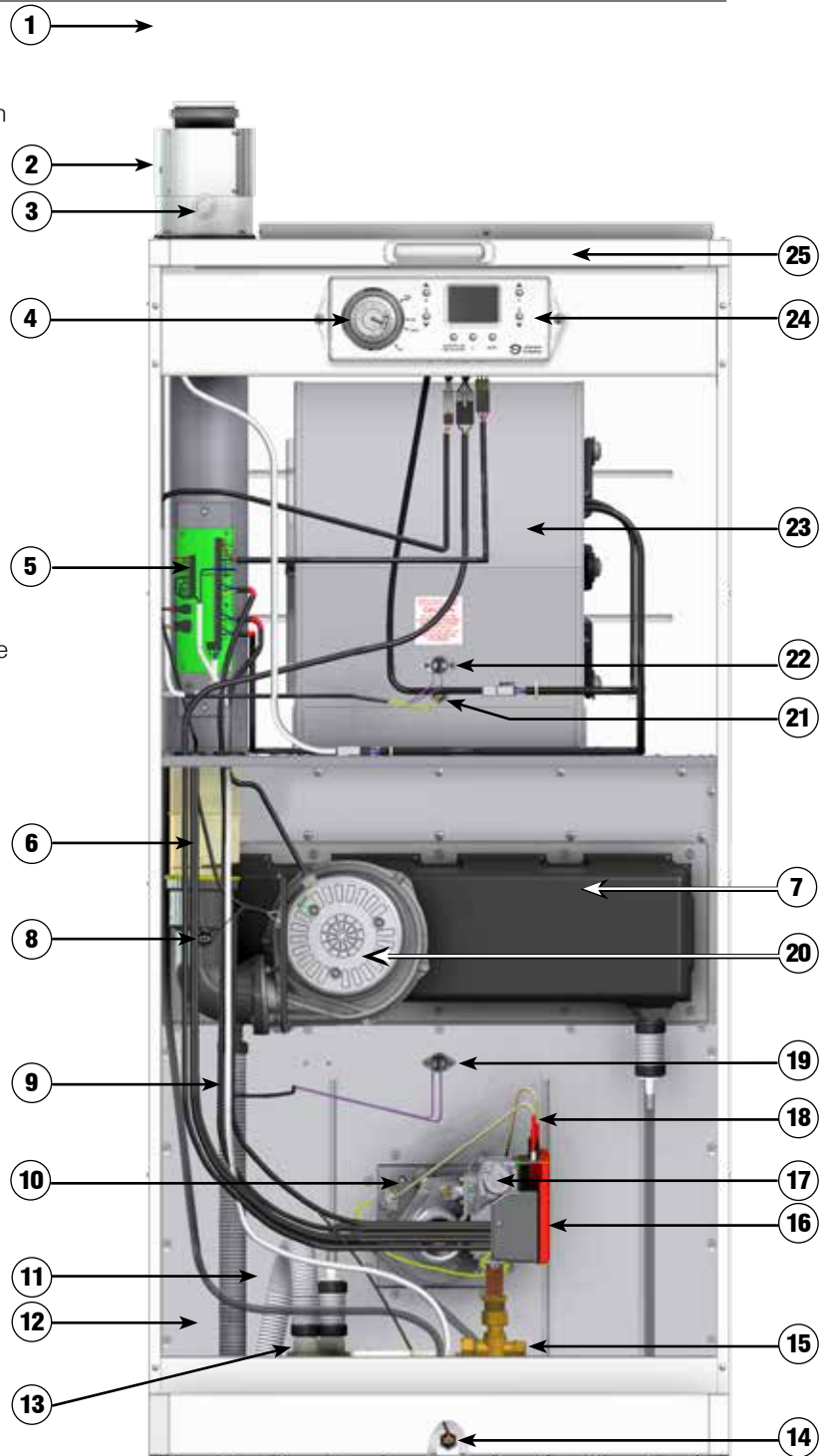

FIGURE 1. C46D FEATURES

2. GENERAL DESCRIPTION

- 2.1 The WarmCair C46D is a highly efficient condensing gas fired downflow forced convection air heater. Significant reductions in Low Carbon and NO_x emissions are achieved. It has been designed to provide the user with on demand Warm Air Central Heating. Using sophisticated controls enabling it to provide the precise amount of heat output to match demand. It is room sealed, with a stainless steel heat exchanger, using a vertical or horizontal Concentric Flue System. The WarmCair C46D air heater is ideally suited for new built dwellings and the replacement of existing non-condensing air heaters.
- 2.2 The air heater output modulates 40.48kW (145.73MJ/h, 138,118 Btu/h) down to 13.2kW (47.52MJ/h, 45,038Btu/h) "Summer Air Circulation" of unheated air is available by manual selection (see the user's instructions).

3. BUILDING STANDARDS & REGULATIONS



STATUTE LAW DEFINES THAT ALL GAS APPLIANCES MUST BE INSTALLED BY COMPETENT PERSONS, i.e. GAS SAFE REGISTERED INSTALLERS.

GAS SAFE MEMBERSHIP ENQUIRIES TEL: 0800 408 5500 IN ACCORDANCE WITH THE GAS SAFETY (INSTALLATION AND USE) REGULATIONS (CURRENT EDITION).

FAILURE TO COMPLY WITH THESE REGULATIONS MAY LEAD TO PROSECUTION.



3.1 INSTALLATION REGULATIONS

- Gas Safety (Installation and Use) Regulations (as amended)
-
- Model and Local Authority Byelaws
- Health & Safety Document No. 635.
- The Electricity at Work Regulations
- Institute of Electrical Engineers (I.E.E) Wiring Regulations
- British System Design Manual “Gas Fired Warm Air Heating”
- EN Regulations No. 1196 Supplementary Instructions - Condensing Air Heaters

3.2 BUILDING STANDARDS AND REGULATIONS

Where no specific instructions are given, reference should be made to the relevant British Standard Code of Practice.

Building Standards (Scotland) (Consolidation) Regulations

Building Regulation (Northern Ireland)

Building Regulations Part L

- BS 6891 Installation of Low Pressure Gas Pipework of up to 28mm (R1) in domestic premises (2nd family gases).
- BS 5440:1 Flues (for gas appliances of rated input not exceeding 70 kW).
- BS 5440:2 Ventilation (for gas appliances of rated input not exceeding 70 kW).
- BS 5864 Installation of Gas Fired Ducted Air Heaters

IMPORTANT: This appliance is CE certificated for safety and performance. It is important that no modifications are made to this appliance, unless fully approved in writing by Johnson & Starley Ltd. If in doubt please ring Johnson & Starley Ltd on Telephone 01604 762881.



GAS LEAKS

DO NOT OPERATE ANY ELECTRICAL SWITCHES, OR USE A NAKED FLAME TURN OFF THE GAS SUPPLY. VENTILATE THE AREA BY OPENING DOORS AND WINDOWS.

CALL THE NATIONAL GAS EMERGENCY SERVICE ON
0800 111999

4. SAFETY & GAS INFORMATION

PLEASE READ THESE INSTRUCTIONS CAREFULLY BEFORE COMMENCING WITH THE INSTALLATION

4.1 GENERAL SAFETY INFORMATION

- 4.1.1 Ensure the mains supply voltage, frequency, number of phases and power rating comply with details on the rating label.
- 4.1.2 All wiring must be in accordance with the appropriate standards. The equipment must be supplied with a double pole isolator switch.
- 4.1.3 Ensure safety regulations and practices are adhered to when installing and using this equipment.
- 4.1.4 The weight of this appliance exceeds that recommended for a one-man lift. It will therefore be necessary to gain assistance at times during the installation procedure.
- 4.1.5 It should be noted that this appliance may contain sharp edges. Care MUST be taken when handling the appliance to prevent injury.
- 4.1.6 Once the appliance has been fired beware that certain parts will be hot to the touch.
- 4.1.7 Do not install flues during rain, high winds or in severe weather conditions.

4.2 GAS INFORMATION

4.2.1 Gas Categories

- a. The appliance is certified as a CAT I 2H (20) appliance.

4.2.2 Gas Supply

- a. The gas installation must be completed in accordance with the relevant standards (BS 6891).
- b. The supply must be capable of providing a steady inlet working pressure to the appliance of 20 mbar at a rate of 4.29m³/h or 151.34ft³/h (Calculated with a Gas C of 38.7MJ/m³)
- c. The installation must be tested for gas tightness using suitable methods. The Pipework should also be purged of air in accordance with the IG Publication Standard.

5. TECHNICAL DATA

C46D						
WEIGHT	96kg					
GAS	G20					
GAS SUPPLY PRESSURE	20mbar					
GAS CATEGORY	I 2 H					
COUNTRIES OF INSTALLATION	GB & IE					
ELECTRICAL SUPPLY	250v ~ 50Hz fused 5A 670 watts					
	MAXIMUM			MINIMUM		
	kW	MJ/h	Btu/h	kW	MJ/h	Btu/h
INPUT (GROSS)	46	165.6	156,952	15	54	51,180
OUTPUT	40.48	145.73	138,118	13.2	47.52	45,038
GAS RATE CV 1037 Btu/FT ³	4.29m ³ /h (151.34ft ³ /h)			1.4m ³ /h (49.35ft ³ /h)		
BURNER % CO ²	9 ± 1			9 ± 1		

TABLE 1. C46D TECHNICAL DATA

6. HEATER POSITIONING

- 6.1 This heater is not suitable for external installation unless it is protected from the elements by a suitable enclosure. The enclosure must provide the clearance for installation, servicing and maintenance as well as the correct level of ventilation. The selected position should allow for a suitable flue system to be installed.
- 6.2 When installed in a timber frame building guidance should be taken from the Gas Industry Publication IGE/UP-7 (Guide for Gas Installations in Timber Frame Housing).
- 6.3 BS 6798 gives details of the essential features for a compartment or cupboard where a gas appliance is to be installed. An existing cupboard may require modifications.
- 6.4 If the heater is installed in a room containing a bath or shower it is important to locate the electrical switch in a position where it cannot be touched by anyone using the bath or shower. The current IEE Wiring Regulations (BS 7671) for England and electrical provision of the Building Regulations for Scotland gives details.
- 6.5 Room ventilation for the heater is not necessary as the heater draws its combustion air from the outside of the building, cupboard or compartment ventilation is not necessary providing that the minimum clearances are maintained. However, reference should be made to BS 5440 Pt. 2.
- IMPORTANT:** This appliance must be completely level. It MUST NOT lean in any direction. Otherwise it will cause problems with the condense draining.

7. HEATER COMPARTMENT CLEARANCES (see BS 5864)

- 7.1 **IMPORTANT** - If the heater is to be fitted to an existing base duct (warm air plenum), always ensure when installing the appliance, the rear of the heater is aligned with the rear of the base duct. If there is any overhang or blanking off it will be at the front of the heater. In any event, blanking plates must be mechanically secured and all joints sealed.
- 7.2 When the heater is fitted into a compartment, a minimum clearance from the compartment walls of 3mm ($\frac{1}{8}$ ") at the sides, rear and front must be left. Where clearances are less than 75mm, internal surface must be lined with non-combustible material and the compartment must be of a fixed rigid structure. However, there is no requirement for the use of non-combustible material at the front of the unit. Consideration should also be given to the space required for the removal and replacement of the filter tray and the entry of the gas and electrical supplies. If gas connections are made from a side entry, a minimum clearance of 75mm (3") is required at that side.
- 7.3 For service access, a minimum of 450mm (18") is required at the front of the heater. Space must also be allowed, in a compartment installation, to permit the removal of the heater.
- 7.4 In airing cupboard installations, the part used as the air heater 7.1 must comply with the relevant section of BS 5864 and must be completely separated by either a non-combustible partition or a perforated metal partition with the perforations not exceeding 13mm ($\frac{1}{2}$ "). The secondary flue must be a tight fit where it passes through the partition and must be suitably protected. See BS 5440: Part 1.
- 7.5 In under-stairs installations, the compartment must comply with the relevant section of BS 5864, provided that in addition all internal surfaces (including the base) are non-combustible or lined with non-combustible material. This requirement is applicable only to dwellings of more than two storeys.
- 7.6 In free-standing installations, (refer to the instructions packed with top closure kit), only one or two walls will be in close proximity to the air heater; these must be non-combustible.
- 7.7 Where the air heater is to be installed onto a combustible surface and under-floor ducting used, a suitable base tray MUST be used in order to provide insulation.
- NB. Where a base plenum is used no base tray is required!
- 7.8 Although two permanent ventilation openings are not required, consideration should be given to the amount of heat emitted by any ductwork present in the compartment, otherwise the compartment temperature could increase and will affect the safe operation of the appliance and its controls.

8. DUCT SYSTEM (See British Design Manual - Gas fired Warm Air Heating)

8.1 RETURN AIR

- 8.1.1 Room-sealed appliances may be installed without return air ducting, provided that the path between the return air grille and the appliance return air inlet is protected in such a manner that the required air-flow will be maintained at all times. The return air grille **MUST** have a free area of not less than 4200cm² (652in²). It is recommended that the return air duct not be routed directly from the main living area, but from a convenient central area serving the remainder of the dwelling.
- 8.1.2 The return air system should be constructed of fire-resistant material. The flue shall not be run through an area serving as a return air plenum. It is extremely important that the correct size of return air grilles and ducting is used. The return air duct area should not be less than 2059cm² (320in²). If flexible duct is used the duct diameter should not be less than 508mm (20") diameter.
- 8.1.3 An adequate and unobstructed return air path is essential from areas not served by a directly ducted return and to which warm air is delivered. All such rooms should be fitted with relief grilles which have a free area of 0.0088m²/kW (1in²/250Btu/h) of heat supplied to the room. The only exceptions are kitchens, bathrooms and WC.'s.
- 8.1.4 The return air duct should allow for ease of removal for access to the flue.
- 8.1.5 All duct work in the room or internal space in which the heater is installed shall be mechanically secured and sealed with ducting tape.

8.2 WARM DELIVERED AIR

- 8.2.1 All duct work, including riser ducts, should be fully insulated with 50mm (2") fibre-glass or similar. If short extended duct runs are taken below floor level these should be similarly insulated and in addition wrapped with a sound vapour proof barrier. They must also be protected from crushing.
- 8.2.2 The duct system should be carefully designed (as given in the guidelines in the British System Design Manual) to suit the needs of specific heating requirements and building layout. The type of duct system (e.g. radial/extended plenum stepped) should be installed using the least number of fittings to minimise airflow resistance. The base duct, which equalises the air pressure to supply ducts, must be constructed to support the weight of the heater, which must be sealed using self-adhesive foam strip, ducting tape or sealing compound. All ducting and blanking plates must be mechanically secured and sealed.

9. FLUE INSTRUCTIONS

- 9.1 The WarmCair C46D Condensing Air Heater is certified as a warm air heater with corresponding flue systems according to EU Directive 2009/142/EC on gas-fired devices. These installation instructions are covered by this certification and are referred to in the design approval test certificate.
- 9.2 The installation of the warm air heater and flue system must be in accordance with the Gas Safety (Installation and Use) Regulations 1998 and the Building Regulations. If no specific instructions are given, reference should be made to the relevant codes of practice.

THESE RELEVANT STANDARDS SHOULD BE FOLLOWED

BS 5440:1 Flues and ventilation for gas appliances of rated heating input not exceeding 70kW (net) : Flues

BS 5440:2 Flues and ventilation for gas appliances of rated heating input not exceeding 70kW (net) : Air Supply
Ensure all legislation, regulations and directives mentioned are observed.

- 9.3 The air/flue duct operates at very low temperatures therefore no clearance is necessary between the air duct and the adjacent services.
- 9.4 Ensure while installation work is being carried out that no debris such as swarf, filings or fragments of mortar are allowed to remain in the air/flue duct.

9.5 FLUE CONFIGURATIONS

NOTE: Vertical Appliance adaptor is fitted as part of the air heater.

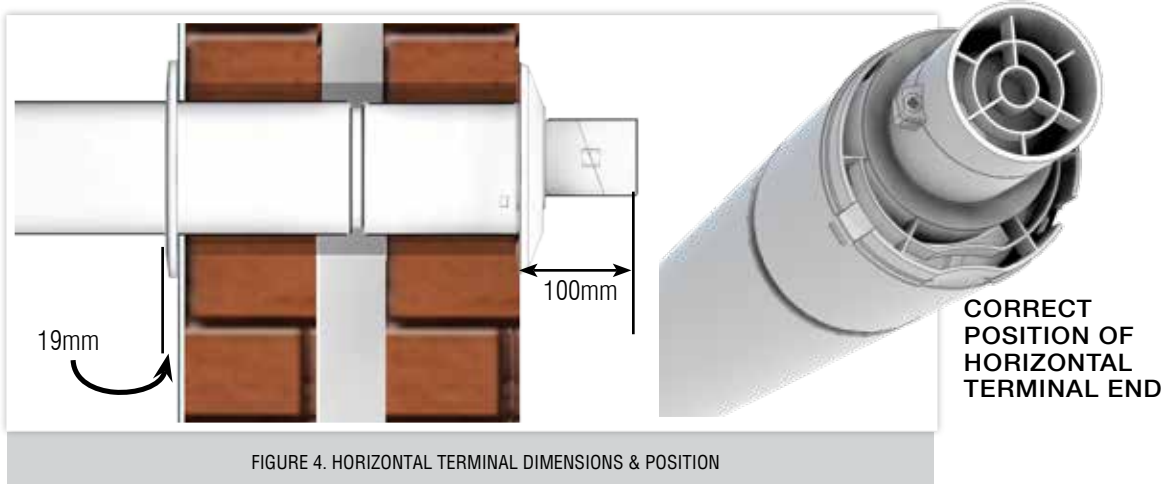
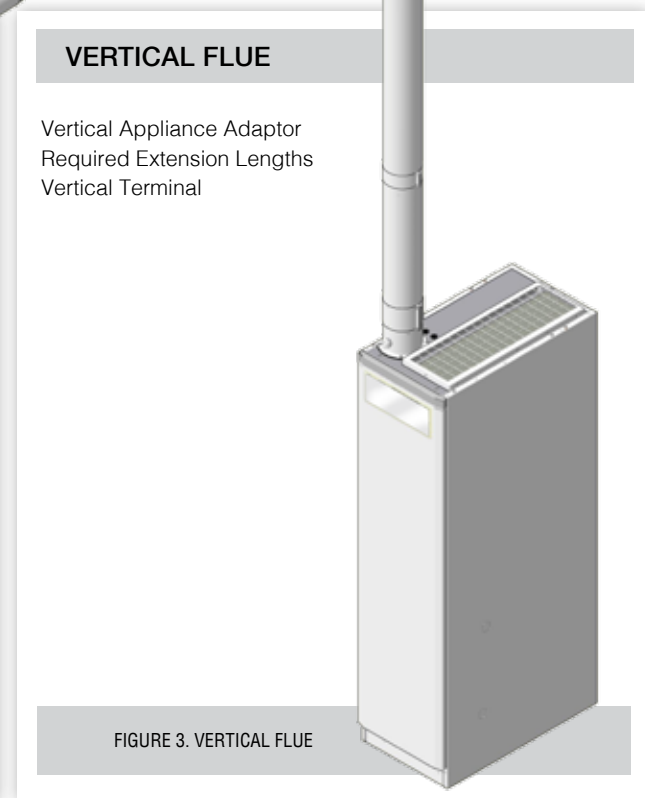
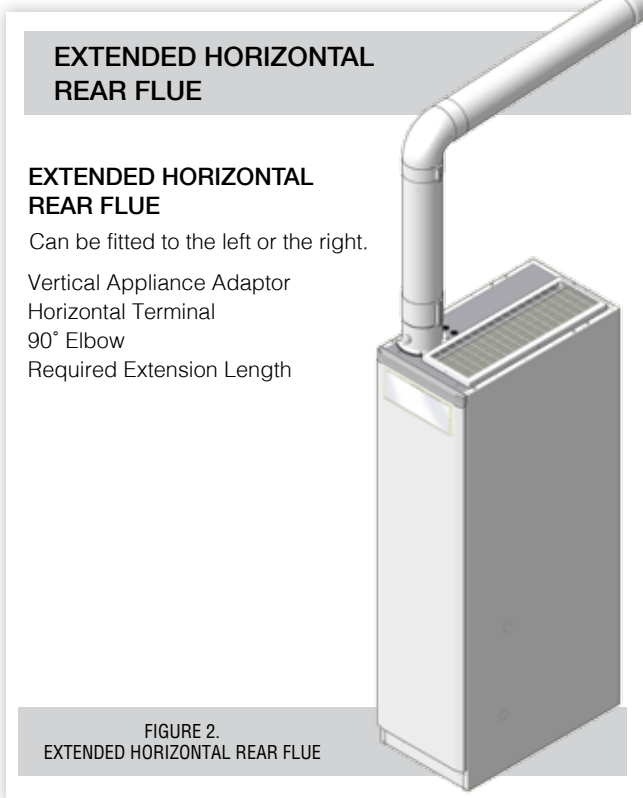



FIGURE 5. TERMINAL POSITIONS

	TERMINAL POSITION	MINIMUM DISTANCE
A	Directly below an opening, air brick, opening window etc	300mm
B	Above an opening, air brick, opening window, etc.	300mm
C	Horizontally to an opening, air brick, opening window etc.	300mm
D	Below gutters, soil pipes or drain pipes.	75mm
E	Below eaves.	200mm
F	Below balconies.	200mm
G	From a vertical drain pipe or soil pipe.	150mm
H	From an internal or external corner. Greater than 450mm protrusion.	300mm
I	Above ground, roof or balcony level.	300mm
J	From a surface facing the terminal.	600mm
K	From a terminal facing the terminal.	1,200mm
M	Vertically from a terminal on the same wall.	1,500mm
N	Horizontally from a terminal on the same wall.	300mm
Q	Above intersection with roof.	530mm
P	From a vertical structure on the roof	300mm
R	From the terminal to the boundary	300mm

TABLE 2. TERMINAL DIMENSIONS

9.6 TYPE OF FLUE SYSTEMS

Two types of flue systems are available for the C46D.

- i) The standard concentric flue system 80/125mm (125mm diameter)
- ii) A Flexible flue kit (FFK) 80/125mm (125mm diameter) For further information contact the sales office at Johnson & Starley Ltd. Telephone 01604 762881.

9.7 FLUE TERMINAL POSITIONS

9.7.1 The following information provides the general requirements for siting flue terminals. As part of the recommendation given in BS 1550 Part 1. For IE recommendations, see the current issue of I.S. 813 “Domestic Gas Installations.” Also publication a “Guide for Gas Installations in Timber Framed Housing DM2” or consult your local gas region, They MUST be consulted when installing the appliance into a timber-framed building.

NOTE: Due to the nature of the warm air heater, water vapour will discharge from the flue. This should be taken into account when siting the flue

9.7.2 Both the extended horizontal and vertical terminals must be positioned on the outside of the building and the free passage of air must be available at all times. It is not recommended to position the terminal close to projections especially under a balcony or near to a drainpipe. See Figure 3.

9.7.3 Ensure that combustion products cannot enter the building where the heater is installed or near to any other building where doors or windows may be open.

9.7.4 Recommended terminal positions for both extended horizontal and vertical flues are shown and flue components and installation options are also detailed.

9.7.5 The flue MUST NOT be installed under a car port.

9.8 PLUME TERMINAL OUTLETS

9.8.1 A flue duct outlet of an appliance should be at least 600mm from the boundary line when facing it and at least 300mm from the boundary line when running parallel to it. See Figure 6.

NOTE: When the flow of products is at an angle to the boundary, the 600mm dimension may be measured in the direction of the flow, as long as the terminal is not less than 300mm from the boundary.

9.8.2 It is recommended the terminals are not sited within 2m of an opening in an adjacent building or within 2m of the boundary facing the terminal if the plume is likely to cause a nuisance to a neighbour, e.g discharging over a walkway or patio.

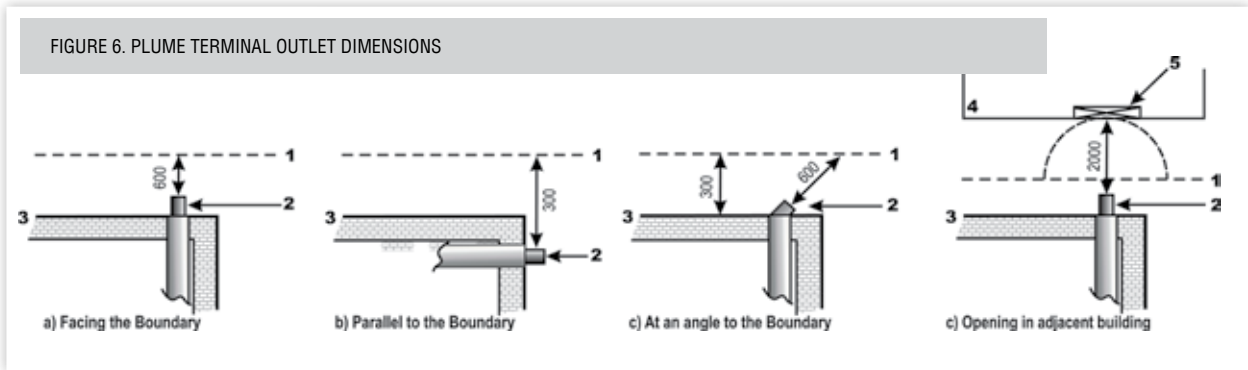

9.9 FLUE REQUIREMENTS & GENERAL INFORMATION

9.9.1 Extended horizontal and vertical concentric flues (80/125mm diameter) with balanced terminals may be installed on the WarmCair C46D warm air heater.

9.9.2 If an extended horizontal flue is being used it must have a continuous fall back towards the appliance of 3° (52mm) per meter. This ensures that condensate runs back into the appliance from the flue system for safe discharge via the condensate waste pipe. Reference should be made to Table 5 for relevant part numbers.

9.9.3 The maximum length of flue permissible is 10 meters including terminal

9.9.4 The minimum vertical flue length is 1.25m from the top of the appliance case to the top of the terminal.

9.9.5 Longer flues may be fitted, however the input of the appliance will be reduced accordingly.

9.9.6 Elbows may be fitted within the flue system with a corresponding reduction in overall flue.

9.9.7 Guidelines for the maximum flue length are as follows.

HORIZONTAL FLUE			VERTICAL FLUE	
UNIT TURRET	90° ELBOW	STRAIGHT 1m FLUE	90° ELBOW	STRAIGHT 1m FLUE
1	-	12	-	12
1	1	8	1	8
1	2	6	2	6
1	3	4	3	4
When using 45° elbows: 2 x 45° elbow = 1 x 90° elbow				

TABLE 3

9.10 CONVENTIONAL 80/125mm FLUE ACCESSORY PARTS No's

	DESCRIPTION		COLOUR	QTY	APPLICATION	PART No.
1	800mm Horizontal Terminal		White	1	Horizontal	1000-0023830
2	Vertical Adaptor 60mm to 80mm		White	1	Vertical	1000-0023810
3	45° Elbow		White	1	Horizontal & Vertical	1000-0020110
4	90° Elbow		White	1	Horizontal & Vertical	1000-0020100
5	500mm Straight Extension		White	1	Horizontal & Vertical	1000-0025590
6	1000mm Straight Extension		White	1	Horizontal & Vertical	1000-0023840
7	2000mm Straight Extension		White	1	Horizontal & Vertical	1000-0025600
8	Flat Roof Weather Collar			1	Vertical	1000-0014890
9	Pitched Roof Collar		Black	1	Vertical	1000-0014900
10	Wall Fixing Bracket 125mm			1	Horizontal & Vertical	1000-0016620
11	1140mm Vertical Terminal		White/Black	1	Vertical	1000-0023820
12	Plume Management Kit		Black	1	Horizontal & Vertical	1000-0020730
13	1000mm Extension Flue 80mm		Black	1	Horizontal & Vertical	1000-0020740
14	90° Elbow 80mm Ø		Black	1	Horizontal & Vertical	1000-0020680
15	45° Elbow 80mm Ø		Black	2	Horizontal & Vertical	1000-0020670
16	Wall Fixing Bracket 80mm		Black	1	Horizontal & Vertical	1000-0020090
17	Flexible Flue Kit 80/125mm	5m	Black	1	Flexible	FFK5
		10m				FFK10
18	Flexible Black Outer Pipe	5m	Black	1	Flexible	1000-0026030
		10m				1000-0025930
19	Flexible Grey Inner Pipe	5m	Grey	1	Flexible	1000-0026040
		10m				1000-0025940
20	Outer/Inner Rigid to Flex Adapter		Grey	1	Flexible	1000-0025950
21	Outer Flex to Rigid Connector		Grey	1	Flexible	1000-0025970
22	Flex to Rigid Transition Connector		White	1	Flexible	1000-00225960
23	Transition Sealing Ring			1	Flexible	1000-0026010
24	Inner Flex to Rigid Connector		Grey	2	Flexible	1000-0025980
25	Outer Flue Pipe Sealing Rings			2	Flexible	1000-0025990
26	Inner Flue Pipe Sealing Rings			1	Flexible	1000-0026000
27	Flue Support Kit			1	Flexible	1000-0026020
28	Draw Cone & Rope			1	Flexible	1000-0026050
29	Chimney Terminal Kit 80/125mm		Black	1	Vertical	CTK-80/125
30	Slimline Terminal		Black	1	Vertical	1000-0026650
31	Flue Terminal Connector		Grey	1	Vertical	1000-0026670
32	Chimney Cover Plate		Grey	1	Vertical	1000-0026640
33	Circlip			1	Vertical	1000-0026680

TABLE 4. 80/125mm FLUE COMPONENTS

9.11 EXTENDED HORIZONTAL FLUE SYSTEM

Extended horizontal flue set up comprises of:

- The required flue lengths up to a length of 10m
- 800mm Horizontal Terminal
- 90° Elbow
- Inside Wall Cover Plate
- Outside Wall Cover Plate
- 125mm Diameter Clamp (1 per flue length)



FIGURE 7. EXTENDED HORIZONTAL FLUE

OPTIONAL ROOF OUTLETS AVAILABLE

9.12 FLAT ROOF OPTION

The Flat Roof Collar.

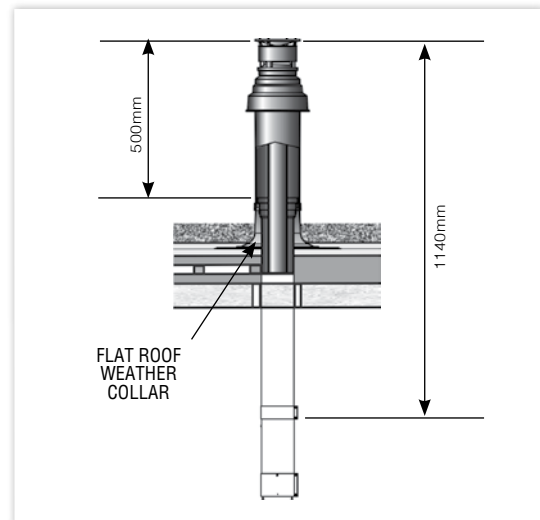

FIGURE 8. OPTIONAL ROOF OUTLET

9.13 PITCHED ROOF OPTION

A Pitched Roof Collar can be fitted on a pitched roof with an angle of between 20° to 50° pitch.

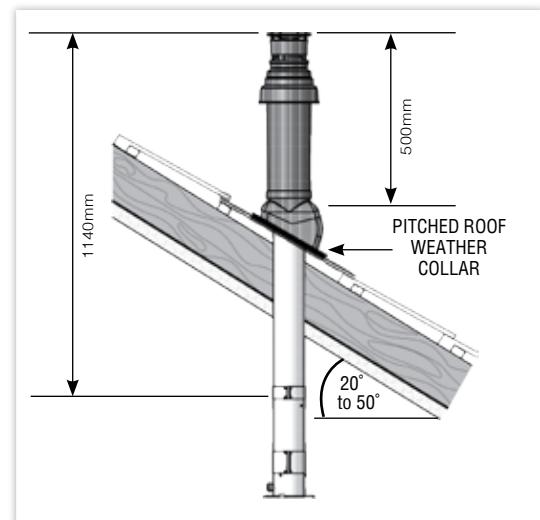

FIGURE 9. OPTIONAL ROOF OUTLETS

10. CONDENSATE PUMP & DRAIN TUBE

10.1 CONDENSATE PUMP

10.1.1 Supplied with 6mm x 7m condense tube. Condense adapter and 2 x clips

SAFETY NOTE: If the pump fails, the safety float switch will shut off the heater operation.

10.1.2 DO NOT HANDLE PUMP IN WET CONDITIONS OR WITH WET HANDS

10.1.3 To reduce the risk of electric shock, ensure the electrical supply is permanently wired to earth

10.1.4 TECHNICAL DATA

- a) Tank capacity : 0.7L
- b) High level safety cut out.
- c) Outlet size 6mm I.D.
- d) Maximum water temperature: 60°

10.1.5 Where the tubing from the pump is connected directly to the soil stack or waste pipe, there must always be either a waste trap after the tubing connections, or a 75mm U trap formed within the tubing.

10.1.6 Where the tubing from the pump is connected to an external soil and vent stack extra care is necessary to ensure that the condense pipe could not be blocked through the condense freezing.

10.1.7 The tank pump uses small bore (6mm) flexible hose which can be **routed above or below doors, windows and under kitchen cabinets.**



FIGURE 11. CONDENSE PUMP

10.2 CONDENSATE TUBE ROUTING OPTIONS

- Option A. Routing to outside drain via sink
- Option B. Routing to drain pipe via roof
- Option C. Routing to bath waste
- Option D. Routing under floor to sink waste

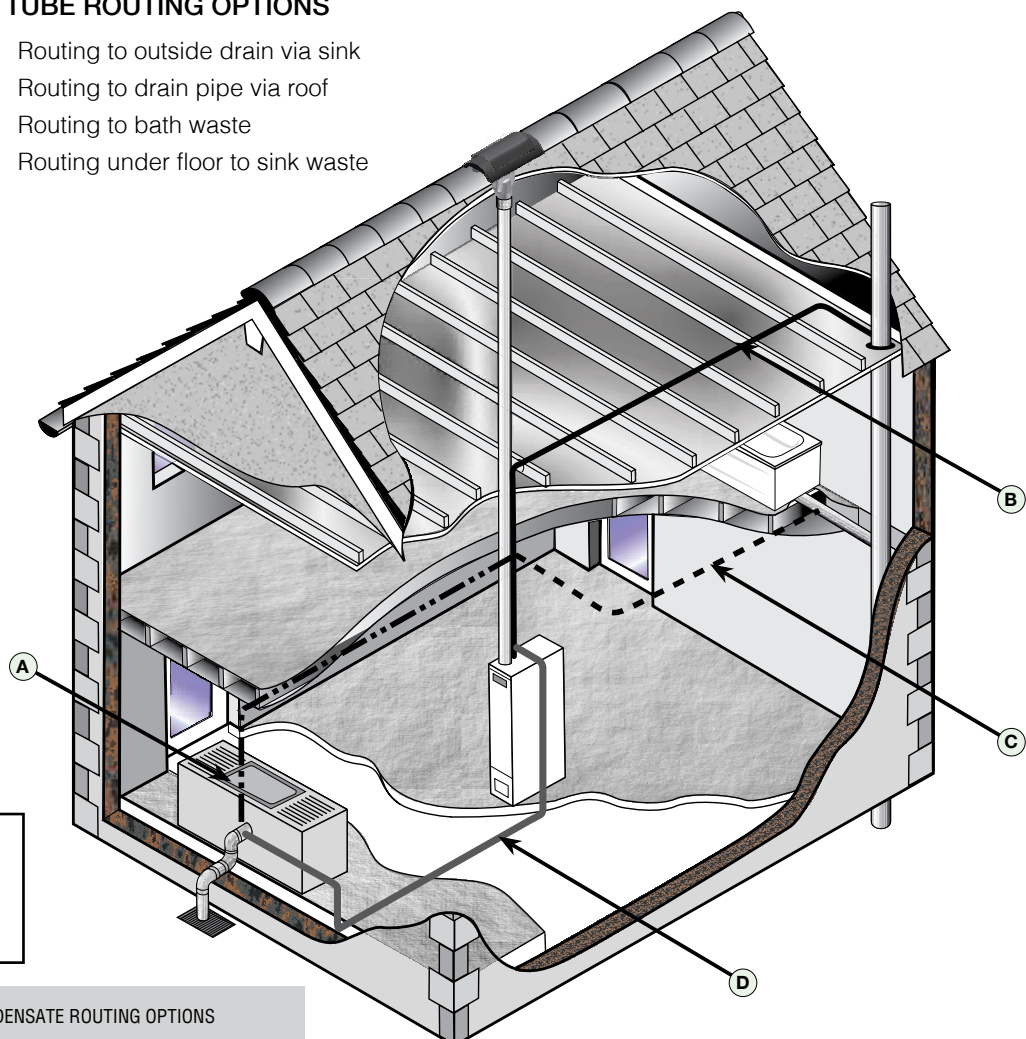

FIGURE 12. CONDENSATE ROUTING OPTIONS

11. GAS (See BS 5864 and BS 6891)

- 11.1 The local gas supply conditions MUST be adequate for the specified burner pressures as stated in the technical specification (section 5).
- 11.2 An independent gas supply pipe from the meter is to be preferred wherever possible. Where this is not possible, the pipe must be capable of taking the complete input of the heater and all other gas appliances being served by the same pipe. This supply should be suitably sized to conform to British Standards requirements of no more than 1.0 mbar (0.4" wg) pressure drop (See table of discharge in BS 6891).
- 11.3 The ¾" union gas cock (supplied) MUST be fitted to the gas inlet of the heater for easy isolation during servicing. The gas pipe should be fitted and installed so as to be durable, substantial and gas tight. To assist in determining where a gas connection may not be tight, a leak detection fluid should be applied around the connection. Under no circumstances should a flame be used to locate a gas leak. Gas entry to the air heater is through either side or the base, to a 22mm compression fitting.

12. ELECTRICAL

WARNING: THIS APPLIANCE MUST BE EARTHED!

12.1 MAINS SUPPLY

The heater is supplied with mains cable (PVC sheathed, heat resisting to 85°C), 3 core: Brown; Blue; Green/Yellow, 6A, 0.75mm²), connected to a terminal block and exiting through the heater at the left hand top. The cable is suitable for a 230V 50Hz supply and requires connection to the fixed wiring using a double pole switched, fused spur with a contact separation of at least 3mm in ALL poles. The fuse fitted must be rated 5A to BS 1362. Connections must also be in accordance with the current edition of I.E.E Regulation BS 7671.

NOTE: If, for any reason, the heater is re-wired, then 3 core cable that meets the above specification MUST be used. Under NO circumstances, should 5 core cable be used for the combined purpose of supplying power to the heater and connecting the thermista-stat!

- Fan delay and overheat (limit controls) are not adjustable and are factory set.
- An Open Therm Controller is supplied which acts like a room thermostat.

12.2 THERMISTA-STAT AND ITS LOCATION

This appliance can be interfaced with the following:-

- Open therm room units (supplied).
- 33k NTC room temperature sensor.
- 230 VAC room thermostats.

12.2.1 The room-stat should be located where there is free air circulation and positioned approx. 1.5m (5ft) from the floor.

12.2.2 Avoid the following locations:

- In a room where temperature is greatly affected by the sun or any other heat source, e.g. radiant fire, wall light fittings or TV set.
- Near an outside door or windows, or on an outside wall.
- Where it will be affected by warm air ducts, diffusers, waste pipes or the heater itself.
- Where it will be subjected to vibration.

12.2.3 Refer to wiring diagram 1 for the installation of the thermista-stat. See Figure 32.

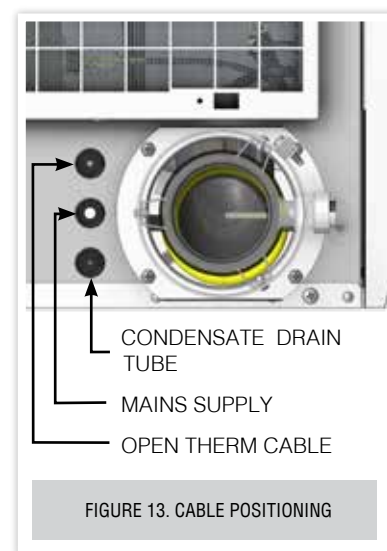

13. FITTING INSTRUCTIONS

CAUTION: This appliance exceeds the recommended weight for a one man lift as detailed in the Manual Handling Operations, 1992 Regulations.

It should be noted that this appliance could contain sharp edges and care MUST be taken when handling.

13.1 FITTING THE APPLIANCE

- 13.1.1 Making sure the plenum is clear from all debris, lift the appliance into place.
- 13.1.2 Using a spirit level it is important the appliance is completely level, this appliance MUST NOT lean or tilt in any direction. This will cause problems with the condensate draining.
- 13.1.3 Seal the unit to the plenum, using ducting tape (not supplied). Ensure a good seal is made.
- 13.1.4 Installation of the condensate tube is a maximum of 10 meters. There should be no trapped kinks in this length of tube.
- 13.1.5 Fix all connections to the appliance ready for commissioning.

14. COMMISSIONING

- 14.1 After installation of the appliance, you MUST do the following:
 - 14.1.1 Test for gas leakage using proprietary detection fluid and seal any leaks found.
 - 14.1.2 Carry out preliminary electrical system checks.
 - 14.1.3 Ensure that:
 - a. the filter, fan and fan compartments are free from obstructions.
 - b. all registers or grilles are open and conform to design specifications.
 - c. the return, relief and ventilation air installations are adequate.
- 14.2 Switch the air heater electrical Supply ON.
- 14.3. To fill the flue condensate trap, disconnect the sliding flue connector and slowly pour tap water into the elbow until you hear the condensate pump operating. Failure to do this will result in a whistling sound. Check for leaks.

NOTE: The appliance must be connected to the mains for the pump to operate.

14.4 SYSTEM BALANCING

- 14.4.1 Press button '7' to put the appliance into Summer Air Circulation mode.
- 14.4.2 Balance the system to provide the required volume proportions at the warm air outlets.

FIGURE 14. CONTROL PANEL

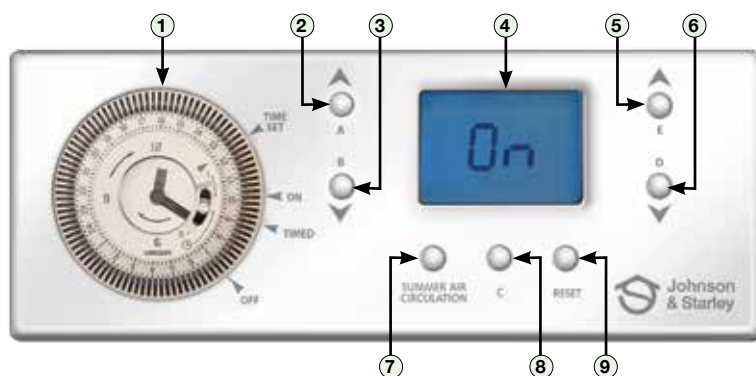
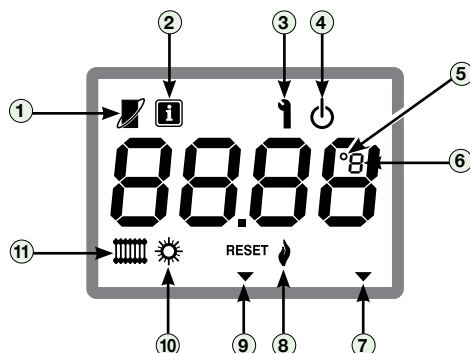

FIGURE 15. LED READ OUT



CONTROL PANEL

1	Time control
2	A +
3	B -
4	LED Display
5	E +
6	D -
7	Summer Air Circulation
8	C
9	Reset

LED READ OUT

1	Open therm symbol
2	Installer mode indicator
3	Service indicator
4	Stand by
5	Degrees
6	Error - 'e' or celsius - 'c'
7	Reset button indicator
8	Flame indicator
9	Button 'c' indication
10	Summer circulation
11	Central heating

NOTE: If the system includes ceiling diffusers, the air through these should be NOT LESS THAN 1.5m/s (300ft/min), except for very small rooms, (i.e. bathrooms etc.). Outlet faces may require partial blanking in order to achieve this.

14.3 LIGHTING MAIN BURNER

- 14.3.1 Turn on the gas supply to the heater.
- 14.3.2 Set both switches on the time control unit to the "OFF" position.
- 14.3.3 Set the thermista-stat to "MAX".
- 14.3.4 Turn on the mains power supply to the heater
- 14.3.5 Set the "AIR HEATER" switch on the time control to "CONT." and observe the ESYS status indicator.
- 14.3.6 The ignitor will spark for 5 seconds during which time the main burners SHOULD ignite and the igniter will stop.
- 14.3.7 The ESYS on the control panel will run through the ID setting, when finished it shows a flashing "--" sign. This shows its ready.
- 14.3.8 If, after the 5 second period, the main burner has ignited the ESYS will show "ON" and the blue LED "ON" light on the indicator panel will remain steady.
- 14.3.9 If the main burner fails to ignite, you have 4 more attempts at ignition.
- 14.3.10 In the event of a lockout "1" and the ignition and main burners failing to ignite, reference should be made to Table 4 in the fault finding section of these instructions in order to establish the fault condition.
- 14.3.11 Allow the air heater to operate for a minimum of 15 minutes to ensure stability.
- 14.3.12 Reset the thermista-stat to the desired comfort level
- 14.3.13 Set the time control to the desired "on and "off" periods.

14.4 GAS RATE CHECK

- 14.4.1 There is no burner pressure test with this air heater. It has a 1-1 ratio Valve.
 - 14.4.2 Natural Gas (G20) consumption is calculated using gross CV 38.7 MJ/m³ or 34.9 MJ/m³ net. Maximum rate 4.29m³/h (151.34ft³/h) and minimum rate 1.4m³/h (49.35ft³/h).
- 14.5 Complete all relevant sections of the Benchmark Commissioning Checklist located on the inside back pages.

NOTE
The gas valve is factory preset and must not be adjusted. A replacement valve must only be supplied by Johnson & Starley Ltd.

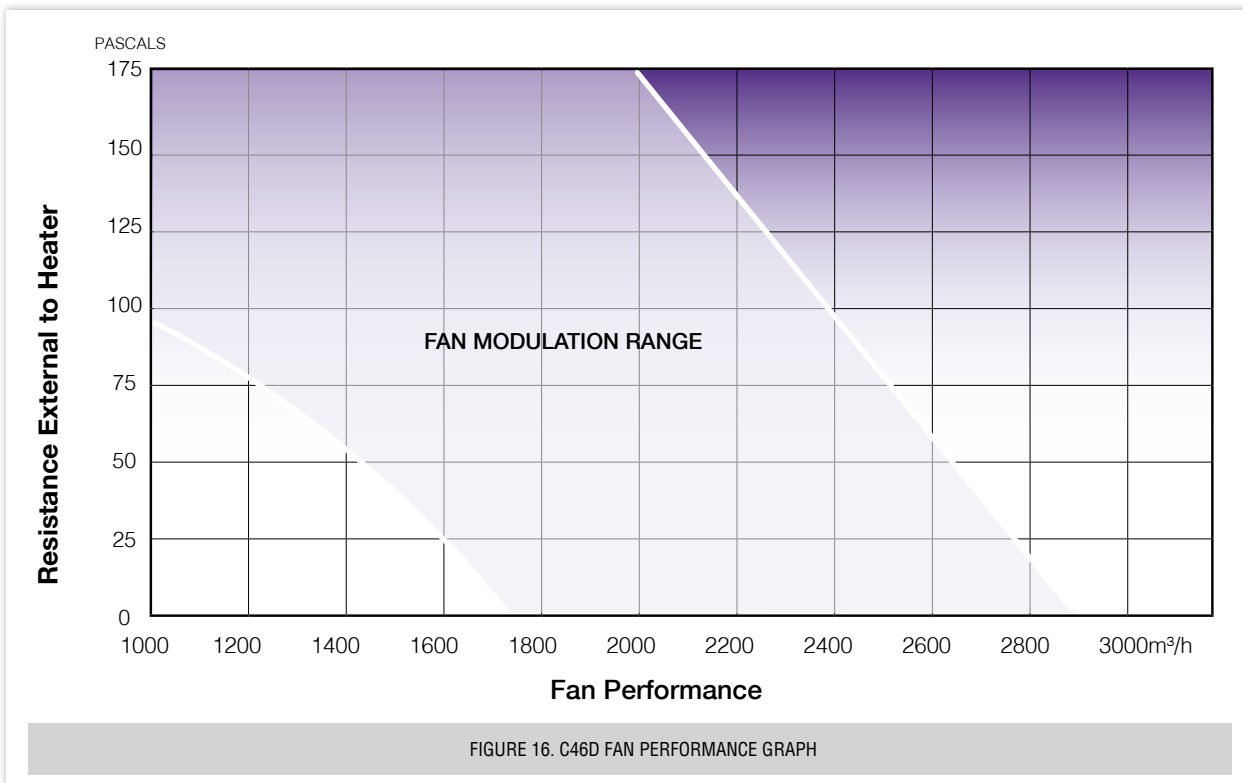

15. HANDING OVER

- 15.1 After commissioning, the installer should hand the appliance over to the occupier of the house by the following procedure:
- 15.2 Hand the User Instructions ZZ1340 to the occupier and explain their responsibilities in respect of current legislation and regulations, both national and local.
- 15.3 Explain and demonstrate how to light and shut down the appliance.
- 15.4 In order to gain the best possible fuel economy in relation to the heating requirements of the household, carefully explain the operation of the appliance and the use/adjustment of all the system controls.
- 15.5 Advise on the precautions required to prevent damage to the appliance; the system and the building in the event of the appliance being shut down in very cold weather.
- 15.6 Explain how, in the event of a fault, the appliance will display a fault code, emphasising that if a fault is indicated they should note the fault code, turn off the appliance and contact a "competent person" which in normal circumstances would be a GAS SAFE registered engineer.
- 15.7 Explain and demonstrate the function/operation of time/temperature controls, emphasising the economic use of the appliance.
- 15.8 A comprehensive service should be carried out ANNUALLY. Stress the importance of regular servicing by a Gas Safe Registered Engineer. In IE servicing work must be carried out by a Registered Gas Installer (RGI).

NOTE

This appliance is not intended for use by persons (including children) with reduced physical, sensory or mental capabilities, or lack of experience and knowledge, unless they have been given supervision or instruction concerning use of the appliance by a person responsible for their safety.

Children should be supervised to ensure that they do not play with the appliance.



REMINDER: At the time of commissioning, complete all relevant sections of the Benchmark Checklist located on the inside back pages of this document prior to handing over the appliance to the occupier.

16.1 SERVICING SCHEDULE

To ensure that the appliance gives continued operation that is both safe and efficient, it is necessary to carry out regular service checks and whilst the period between servicing will depend on the installation condition and the demands placed upon the appliance, it is recommended that the appliance be serviced annually.

IMPORTANT: It is a statutory requirement that ALL work be carried out by a “competent person” which in normal circumstances would be a GAS SAFE registered engineer.

NOTE: In order to carry out either servicing or replacement of components the heater front door must be removed.

16.2 SERVICING SEQUENCE

16.2.1 Light the heater and carry out a pre-service check, noting any operational faults.

16.2.2 Check the gas consumption.

16.2.3 **Put the appliance in test mode. Refer to paragraph 18.1. Connect a suitable flue gas analyser to the sampling point on the top of the air heater or into the flue terminal if access is possible (optional test). See Figure 17.**

16.2.4 **For correct air heater operation, the CO to CO₂ ratio should be checked at the maximum and minimum in test mode.**

16.2.5 **Check that the gas input is at least 90% of the nominal.**

WARNING. Always turn OFF the gas supply at the gas service cock and switch OFF. Disconnect the electricity supply to the appliance before servicing.



FIGURE 17.
GAS FLUE TEST POINT

COMPONENT SERVICING CHECKLIST

- 1 16.2.6 Clean and check the main burner and electrodes. See paragraph 16.4.
- 16.2.7 Visually check combustion chamber, removing any debris. See section 16.8.
- 2 16.2.8 Remove the Combustion Air Fan (CAF) and clean. See section 16.8.
- 16.2.9 Check the condensate pipes and tubes for blockages.
- 16.2.10 Check that the flue terminal is unobstructed and that the flue system is fully assembled correctly.
- 3 16.2.11 Remove the Air Circulation Fan (ACF) and filter, inspect and clean. See paragraph 16.7.
- 16.2.12 After completing the servicing or exchange of components, always test for gas tightness and carry out functional checks as described above.
- 16.2.13 When work is complete, check the condition of the sealing foam in the inside of the front door panel. When the door is refitting you must make ensure a good seal is made.
- 16.2.14 After servicing, complete the relevant Service Interval Record section of the Benchmark Checklist located on the inside back pages of this document.

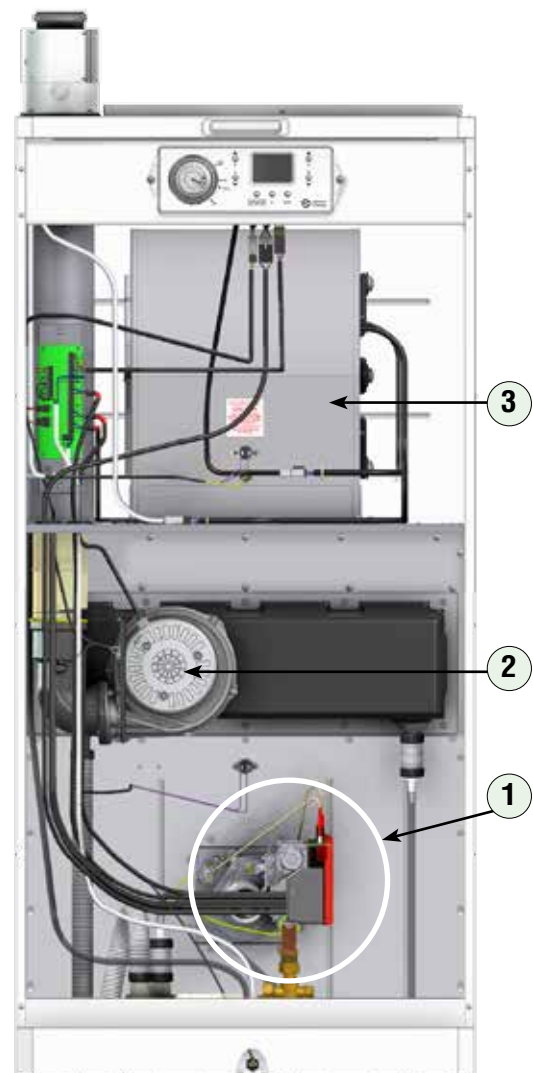

FIGURE 18. SERVICING SEQUENCE

16.3 GAINING ACCESS FOR SERVICING

- 16.3.1 Ensure the electrical & gas supply is isolated as needed.
- 16.3.2 Remove the return air filter and pull the bottom front panel off.
- 16.3.3 Remove the front panel by unscrewing the 4 retaining screws at top and bottom.
- 16.3.4 Remove the front cover.

16.4 MAIN BURNER ASSEMBLY

- 16.4.1 Refer to section 16.3. See Figure 19.
- 16.4.2 Disconnect the gas pipe at the top of the isolation valve.
- 16.4.3 Disconnect the electrode, igniter and earth leads from the ESYS, then remove the screw and panel on the ESYS and remove. Disconnect the electrical connections.
- 16.4.4 Remove the two screws from the valve/venturi assembly and withdraw.
- 16.4.5 Remove the 4 nuts and washers securing the burner assembly to the heat exchanger and withdraw the assembly, take care not to damage the internal ceramic pad.
- 16.4.6 Inspect the inside of the burner assembly for debris. Clean with a soft brush if necessary.
- 16.4.7 Inspect the gaskets and replace if necessary.
- 16.4.8 Inspect and clean the spark ignition and flame sensing electrode, removing any debris and oxidization. Check the spark gap and position of the spark electrode and the positioning of the flame sensing electrode.
- 16.4.9 Once reassembled re-check electrode and igniter nuts are tight.
- 16.4.10 Refit in reverse order ensuring a good seal is made.

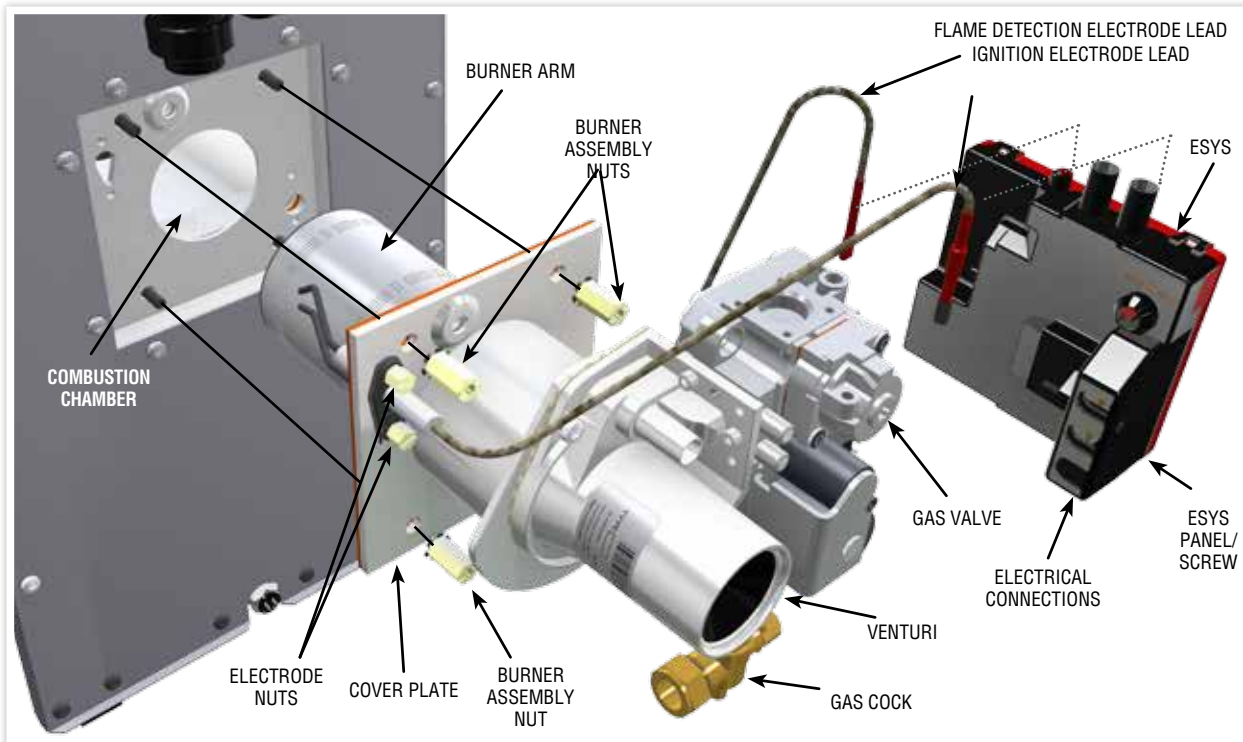

FIGURE 19. MAIN BURNER ASSEMBLY REMOVAL

16.5 IGNITION & FLAME DETECTION ELECTRODE

- 16.5.1 Refer to section 16.3. See Figure 19 & 20.
- 16.5.2 Follow 16.4.4 to remove the valve/venturi.
- 16.5.3 Unscrew the two nuts that retain the electrode to the cover plate and remove the assembly.
- 16.5.4 Inspect and clean the electrode, removing any debris and oxidization. If necessary use an abrasive paper or cloth.
- 16.5.5 Inspect the gasket and replace if necessary during re-assembly.
- 16.5.6 Repeat sequence for the flame detection electrodes with the exception of the earth lead.
- 16.5.7 Refit in reverse order and tighten nuts.

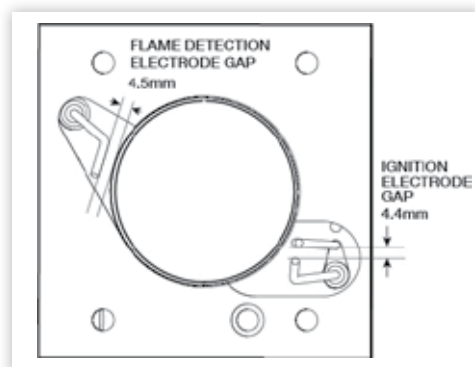

FIGURE 20. ELECTRODE GAPS

16.6 HEAT EXCHANGER/COMBUSTION CHAMBER

16.6.1 Refer to section 16.3 and 16.4. See Figure 19.

16.6.2 Once the burner assembly has been removed inspect the inside of the combustion chamber for debris. If the inner insulation is damaged, do NOT try to clean. Replace the heat exchanger.

16.7 COMBUSTION AIR FAN (CAF)

16.7.1 Isolate the gas supply and refer to section 16.3.

16.7.2 To release the sliding flue connection, slide upwards.

16.7.3 Unplug the multi pin plug connections from the fan and remove the connector from the flue sensor. See Figure 21.

16.7.4 Carefully remove the condensate pipe from the bottom of the flue elbow. This will contain water.

16.7.5 Rotate the CAF and elbow assembly 45° clockwise and withdraw complete assembly.

16.7.6 Carefully inspect both the impellor.

NOTE: Pre 2016 models inspect the mesh in the collection box for debris. If the mesh is full replace with new.

16.7.7 Refit in reverse order.



FIGURE 21.
COMBUSTION AIR PASSAGE REMOVAL

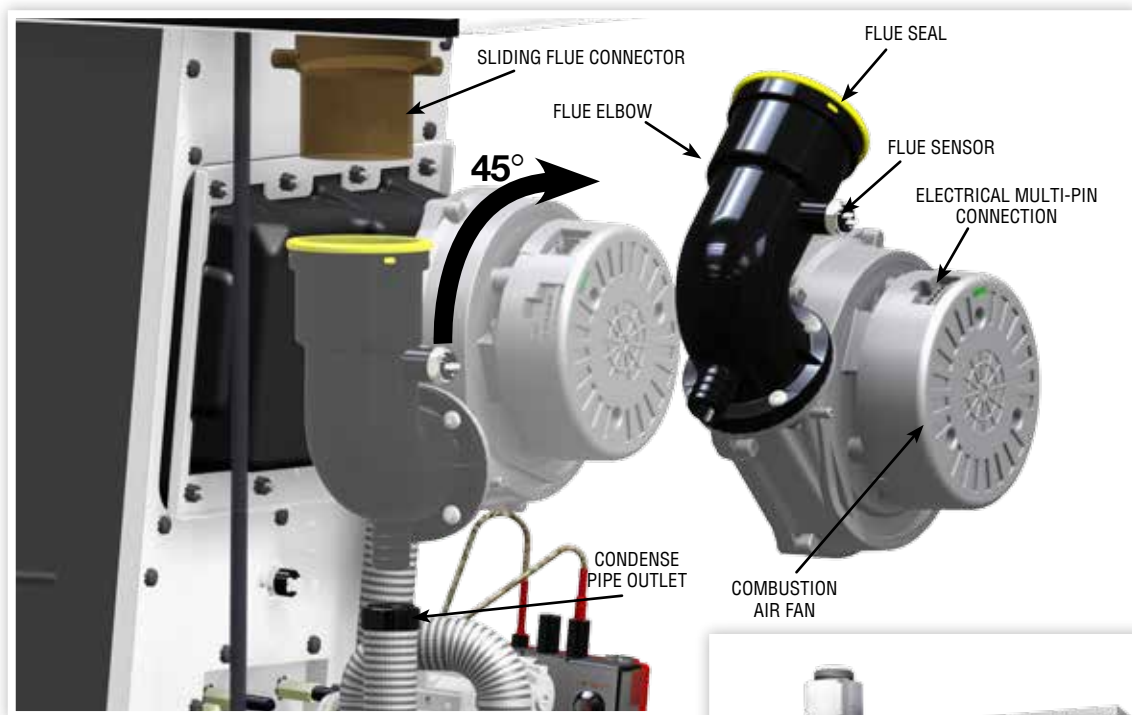

FIGURE 22. COMBUSTION AIR FAN

16.8 AIR CIRCULATING FAN (ACF)

16.8.1 Refer to section 16.3.

16.8.2 Unplug sensor wires and tubes from the air pressure switch, main power connector and low voltage flying leads.

16.8.3 Release the fan assembly securing screws and withdraw the fan from the heater cabinet. Avoid damaging the fan blades. See Figure 23.

16.8.4 Remove all dust from both the impellor and motor, taking care not to disturb the balance of the fan.

16.8.5 Refit in reverse order.



FIGURE 23.
FILTER & AIR CIRCULATION FAN

FIGURE 24. CONDENSE PUMP

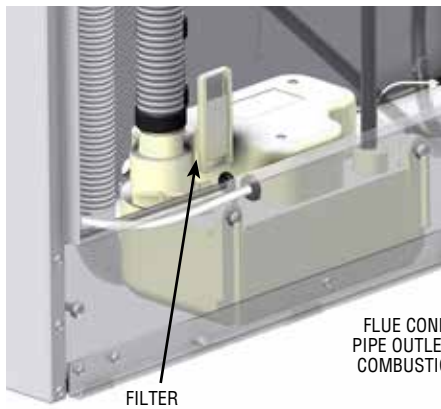

FILTER

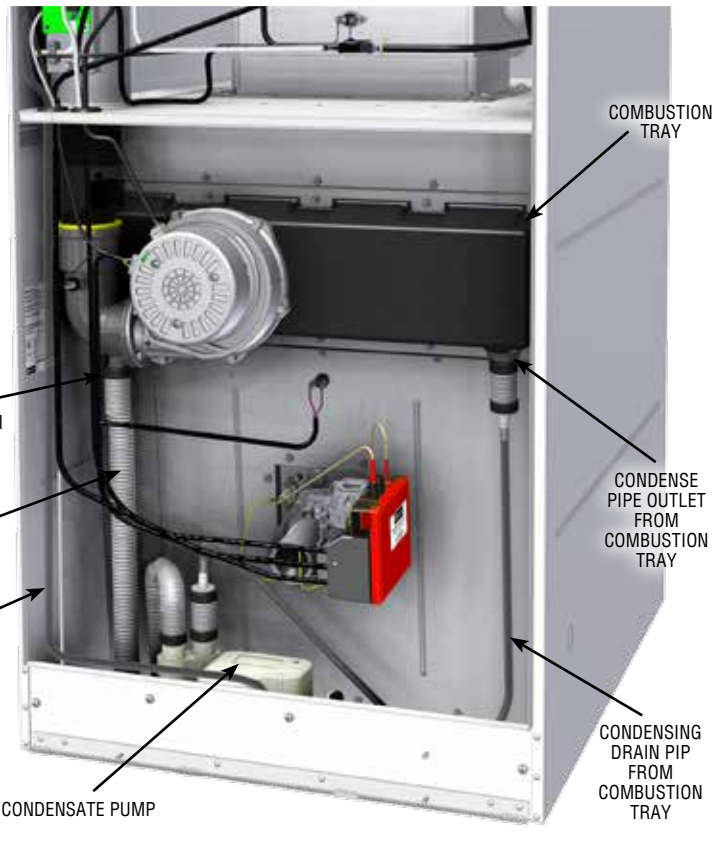

FIGURE 25. CONDENSE PIPEWORK LAYOUT

16.9 CONDENSATE DRAIN PIPES

- 16.9.1 Refer to section 16.3. See Figure 25.
- 16.9.2 Be careful when disconnecting the drain pipes and tubes, they will contain water. Drain as necessary.
- 16.9.3 The flexible condensate pipes are push fit. Disconnect the pipes from the condense pump and combustion tray.
- 16.9.4 Make sure there are no blockages in the condense pipes and tubes.
- 16.9.5 Reconnect the condense drain pipe to the condense pump.
- 16.9.6 Disconnect the flue elbow outlet and pour water into the condense drain pipe and check for leaks. Re-connected the pipe to the flue outlet.
- 16.9.7 Refit in reverse order.

IMPORTANT: Ensure the condensate tube is protected and can not freeze in an unheated area.

16.10 CONDENSATE PUMP

- 16.10.1 Refer to section 16.3. See Figure 25.
 - 16.10.2 Disconnect the electrical connections on the electrical panel for Condense Pump and float switch.
- PLEASE NOTE** The condensate pump, pipes and tubes will contain water.
- 16.10.3 Check the filter for debris. Make sure there are no blockages in the condense pipes and tubes.
 - 16.10.4 Check the inlet and outlet pipe ensuring there are no restrictions to the flow.
 - 16.10.5 Refit the filter.
 - 16.10.6 Reconnect the condense drain pipe to the condense pump, leaving the flue outlet disconnected, pour water into the flue pipe outlet to fill the condensate drain pipe and check for leaks. Re-connected the pipe to the flue outlet.

IMPORTANT: The condensing tube from the combustion tray **MUST** be routed to tube form an 'S' shape, making a 'U' trap. Fit the tube behind the Condensate Trap to hold it in place.

- 16.10.7 Continue to re-fit in reverse order.

17. REPLACEMENT PARTS

- 17.1 **IMPORTANT:** Before commencing with any part replacement the appliance should be isolated from the electrical supply and the gas service cock on the appliance closed.
- 17.1.1 All parts removed should be replaced and refitted in reverse order, ensuring correct seals are made and wires are connected correctly.
- 17.1.2 Remove any debris from within the appliance.
- 17.1.3 When gas-carrying components are replaced the appliance must be tested for gas tightness.

17.2 CONTROL PANEL

- 17.2.1 Refer to section 16.3.
- 17.2.2 Because of the complexity and delicate nature of the control panel assembly, it is supplied as a complete kit in a plastic housing.
- 17.2.3 Remove the control panel by unscrewing the 2 screws that hold the module in place, withdraw and unplug the flying leads at the rear and remove the assembly.
- 17.2.4 Fit new and re-fit in reverse order.

17.3 AIR CIRCULATION FAN ASSEMBLY (ACF)

- 17.3.1 Refer to section 16.3.
- 17.3.2 Unplug sensor wires. Main power connector and low voltage flying leads.
- 17.3.3 Release the fan assembly securing screw and withdraw the fan assembly from the heater cabinet. See Figure 26.
- 17.3.4 Fit the new fan assembly and re-fit in reverse order.



FIGURE 26.
AIR CIRCULATION FAN ASSEMBLY

17.4 FAN FAILURE TEMPERATURE SENSOR

- 17.4.1 Refer to section 16.3.
- 17.4.2 Remove the Air Circulation Fan. Refer to 16.7.
- 17.4.3 Unplug the 2 wires from the temperature sensor and remove the 2 retaining screws. See Figure 27.
- 17.4.4 Fit new and re-fit in reverse order.

17.5 RETURN AIR TEMPERATURE SENSOR

- 17.5.1 Refer to section 16.3.
- 17.5.2 Remove the air circulation fan assembly as described in section 16.7.
- 17.5.3 Unscrew securing nut and remove sensor.
- 17.5.4 Fit new and re-fit in reverse order.

17.6 FLUE TEMPERATURE SENSOR

- 17.6.1 Refer to section 16.3.
- 17.6.2 Carefully remove the 2 spade connectors from the sensor and unscrew the sensor from the plastic flue elbow. See Figure 27.
- 17.6.3 Fit new and re-fit in reverse order.

17.7 HIGH LIMIT TEMPERATURE SENSOR

- 17.7.1 Refer to section 16.3.
- 17.7.2 Unplug the 2 wires from the temperature sensor and remove the 2 retaining screws. See Figure 27.
- 17.7.3 Fit new and re-fit in reverse order.

17.8 DUCT TEMPERATURE SENSOR

- 17.8.1 Refer to section 16.3.
- 17.8.2 Unscrew securing nut and remove sensor.
- 17.8.3 Fit new and re-fit in reverse order.

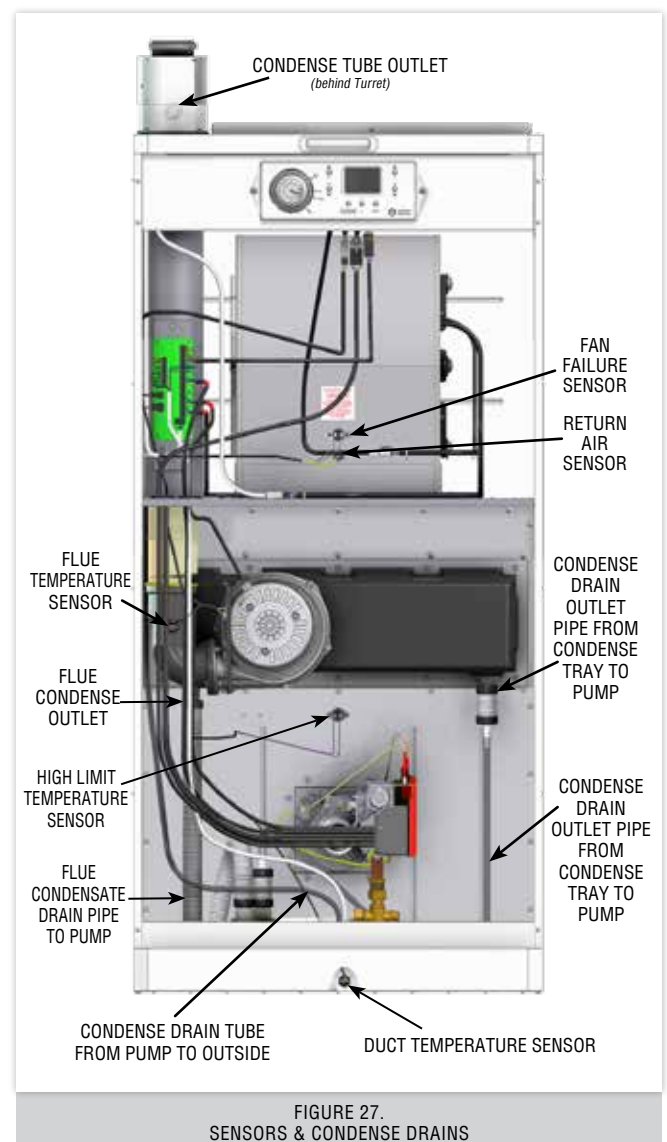

FIGURE 27.
SENSORS & CONDENSE DRAINS

17.8 CONDENSATE PUMP

- 17.8.1 Refer to section 16.3. See Figure 24 & 28.
- 17.8.2 Disconnect the electrical connections on the electrical panel for the Condensate Pump.
- 17.8.3 Disconnect the drain pipes and tubes.
- 17.8.4 Clean the filter rinsing it with clear water and remove any debris.
- 17.8.5 Check the inlet and outlet pipe ensuring there are no restrictions to the flow.
- 17.8.6 Reconnect the condensate drain pipe to the condensate pump, leaving the flue outlet disconnected, pour water into the flue pipe outlet to fill the condensate drain pipe and check for leaks. Re-connected the pipe to the flue outlet.

IMPORTANT: The condensing tube from the combustion tray **MUST** be routed so the tube forms a 'S' shape, making a 'U' trap. Fit the tube behind the Condensate Trap to hold it in place.

- 17.8.7 Continue to re-fit in reverse order.

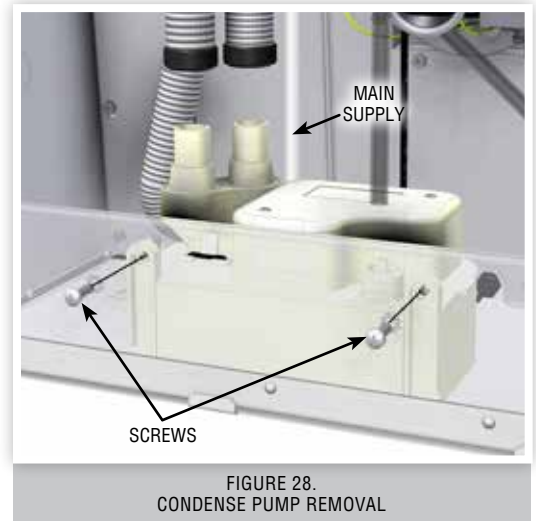

FIGURE 28.
CONDENSATE PUMP REMOVAL

17.9 MAIN IGNITION/CONTROL PCB (ESYS Red Housing on Gas Valve)

- 17.9.1 Refer to section 16.3 and See Figure 29.
- 17.9.2 Unplug the connections from the top of the control and remove the ignition spark detection wires.
- 17.9.3 Unscrew the single retaining screw. Remove cover & unplug the multi-pin connections from the control. Slide the housing off the gas valve electrical connections.
- 17.9.4 Replace with the new ignition control PCB and re-fit in reverse order.

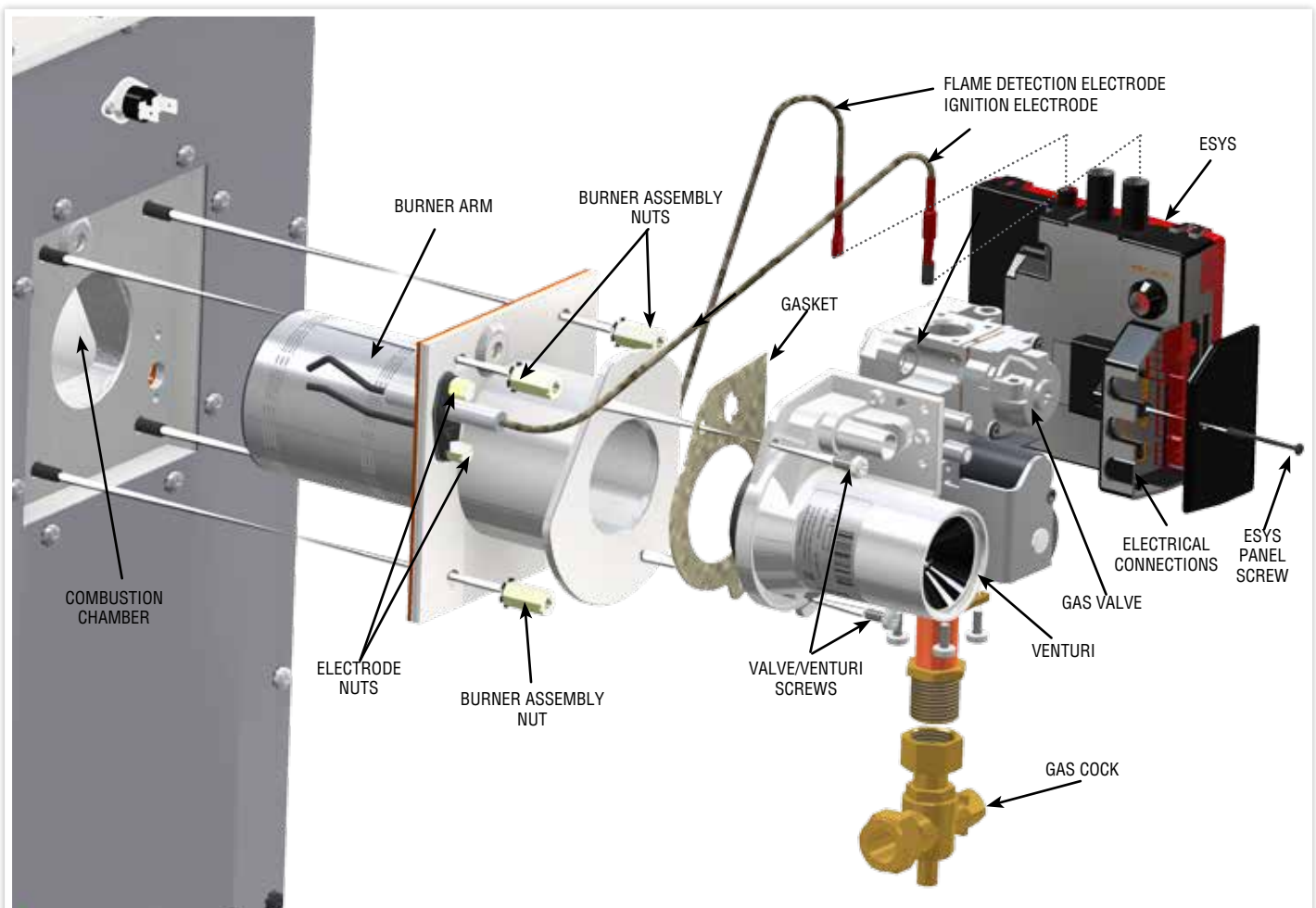

FIGURE 29. MAIN BURNER ASSEMBLY

17.10 GAS VALVE & VENTURI ASSEMBLY

NOTE: The gas valve is factory preset and must not be adjusted. A replacement valve can only be supplied by Johnson & Starley Ltd.

- 17.10.1 Remove the 2 fixing screws securing the venturi (and gas valve to the burner and remove the assembly from the burner carefully removing the gasket.
- 17.10.2 Replace with the new component and re-fit in reverse order, ensuring all the seals are in good condition and correctly positioned.
- 17.10.3 Check the gas rate and combustion as described in paragraph 14.4.

17.11 BURNER ASSEMBLY

- 17.11.1 Refer to section 16.3. See Figure 29.
- 17.11.2 Unscrew the gas joint at the top of the gas cock.
- 17.11.3 Remove the ESYS (red ignition box) & gas valve/venturi assembly. Refer to 17.9 & 17.10 and Figure 19 & 29.
- 17.11.4 Remove the 4 nuts and washers securing the burner assembly.
- 17.11.5 Carefully withdraw the assembly from the heat exchanger.
- 17.11.6 Remove the spark detection electrodes, allowing the burner sealing plates to be separated.
- 17.11.7 Fit new and re-fit in reverse order. Make sure all gaskets are replaced with new ones, ensure the rotation position of the burner is correct (indicated by a notch) and the viewing window is in correct position
- 17.11.8 Re-fit in reverse order.

17.12 IGNITION ELECTRODES

- 17.12.1 Refer to section 16.3. See Figure 29.
- 17.12.2 Unplug the lead from the ESYS (red ignition box) and earth wire from the back of the electrode. Refer to 17.9 and Figure 19 & 29.
- 17.12.3 Remove the 2 remaining nuts and withdraw the electrode.
- 17.12.4 Replace with a new unit, ensuring the gasket is replaced with a new one, or if the existing gasket if reused is in good condition.
- 17.12.5 Re-fit in reverse order.

17.13 FLAME DETECTION ELECTRODES

- 17.13.1 Refer to section 16.3. See Figure 29.
- 17.13.2 Unplug the lead from the ignition control. See Figure 21.
- 17.13.3 Remove the two retaining nuts and withdraw the electrode.
- 17.13.4 Replace with new unit, ensuring the gasket is replaced with a new one.
- 17.13.5 Re-fit in reverse order.

IMPORTANT: When either the ignition or flame detection electrodes have been serviced or replaced you MUST set the clearances as shown in Figure 20.

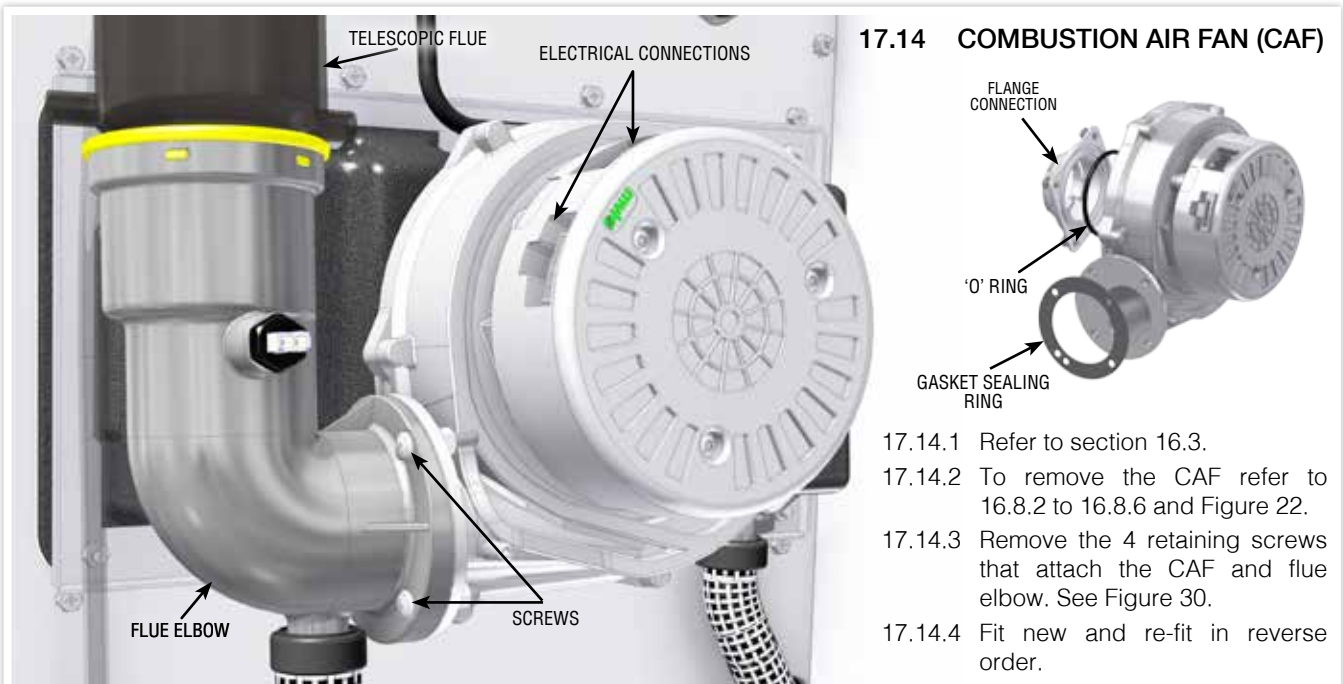

- 17.14.1 Refer to section 16.3.
- 17.14.2 To remove the CAF refer to 16.8.2 to 16.8.6 and Figure 22.
- 17.14.3 Remove the 4 retaining screws that attach the CAF and flue elbow. See Figure 30.
- 17.14.4 Fit new and re-fit in reverse order.

FIGURE 30. COMBUSTION AIR FAN ASSEMBLY

18. CONTROL PANEL MODES

FIGURE 31. CONTROL PANEL

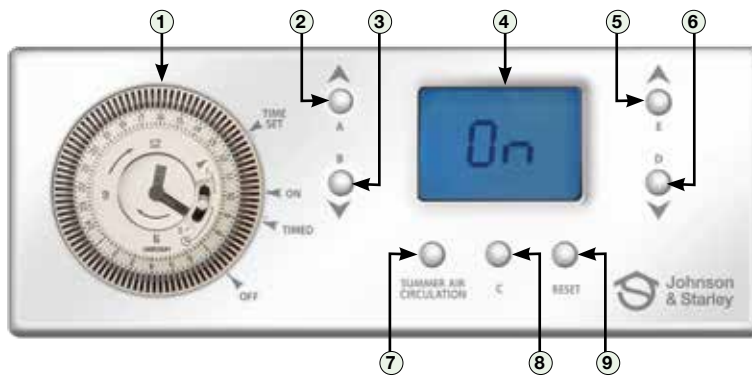

CONTROL PANEL

1	Time control
2	A +
3	B -
4	LED Display
5	E +
6	D -
7	Summer Air Circulation
8	C
9	Reset

18.1 TEST MODE

- 18.1.1 To put the appliance in test mode, press Summer Air Circulation (SAC) and C buttons together for more than 3 seconds, until the display changes. (Possible 5 second time delay.) t100 is displayed along with the flame symbol.
- 18.1.2 Whilst in test mode, the appliance overrides all temperature setting and defaults to maximum rate. Pressing the D and E buttons allows you to scroll between maximum and minimum rates, whilst maintaining all protection and error conditions.
- 18.1.3 Press RESET to take the appliance out of test mode. If no changes are made, the appliance will stay in test mode for 30 minutes.

18.2 AIR CIRCULATION FAN MODE

- 18.2.1 This mode can be used to adjust the maximum and minimum fan speed output value allowed to drive the ACF fan. (minimum value of 50 to 100 being maximum)
- 18.2.2 Put into ACF mode by pressing 'C' and 'RESET' for 3 seconds. The ACF fan will run with the fan speed value showing on the LCD display, the Value from the ESYS is bypassed.
- 18.2.3 On the display, letter F and the fan speed value will display, this value can be changed by pressing the A and B buttons accordingly. Once the required value is reached the values can be saved as:
- minimum by pressing button D
 - maximum by pressing button E
- 18.2.4 The display will flash for 2 seconds to confirm it has been saved to the ESYS.
- 18.2.5 Timeout mode is set for 30 minutes, this can be terminated by pressing RESET.
- 18.2.6 The backlight stays on when the test mode is active.

18.3 ERROR HISTORY MODE

- 18.3.1 The control panel can store the last 8 error codes. To access these codes press the RESET button for more than 1 second, this will then flash 'H1' on the LCD display.
- 18.3.2 Error 1 being the most recent, along with the error code after the dot. To scroll through the error history press the 'C' button.
- 18.3.3 The unit will stay in error history mode for 30 seconds.
- 18.3.4 To take the unit out of the error history mode press RESET.
- 18.3.5 In order to limit the warm air temperature the heater will shut off the burner and Lt will be displayed in the centre of the display. This will be stored as Error 57.
- 18.3.6 Check the filter is clean and the warm air outlets are open.

19. FAULT CODE TABLE

19.1 CAUTION

Before commencing any mechanical servicing the appliance should be isolated from the electrical supply and the gas service cock on the appliance closed. All parts that are removed during a service operation should be replaced in reverse order, ensuring correct seals are made and wires are connected correctly. During the service remove any debris from within the appliance. When gas-carrying components are serviced the appliance must be tested for gas tightness after re-assembly. On completion of a service carry out a full functional test of all appliance components and ensure system controls are operating correctly.

TABLE 4		ERROR CODES	
CODE	SYMPTOM	POSSIBLE CAUSE	ACTION
N/A	Heater will not run	No call for heat to heater control board	Check all external controls (if fitted)
			Check setting on time clock
			Check setting of heater controls
1	Flame lockout after several attempts	Flame not detected	Check gas supply and gas cock
			If burner lights, check flame sensor and wiring to control board
			Check operation of gas valve
2	False flame lockout	False flame detected	Check wiring on ESYS
3	Condense pump failure	Power to the pump	Check for any blockages, restrictions or frozen pipes
4	Air pressure switch open	Circulation air fan not running	Check for any dust restrictions or blocked filter
5	No tacho from fan	Fan not running or wiring fault	Check that fan runs
			Check wiring between ESYS and fan
7	Flue gas protection	High flue gas temperature	Check airflow and fan operation
8	Flame circuit error	Flame sensing lead shorted to earth	Check flame detection lead between sensing probe and ignition control board
9	Valve driver circuit error	Gas valve not detected	Check that ESYS is corrected fitted on gas valve
			Replace ignition control board or gas valve
13	Remote reset lockout	Exceeded 5 remote resets per hour	Reset it by power off/on
21	ADC error		Change ESYS
25	CRC error	Different software versions	Change ESYS
26	Flame lost signal lost 5 times in 4 minutes	Flame sensing error. Failing gas pressures. Fan fault. Flue blockage.	Check flame detection lead between sensor and ignition control board
			Check the gas supply, does pressure fall when burner fires?
			Check that flue system is not blocked

BLOCKING CODES

CODE	SYMPTOM	POSSIBLE CAUSE	ACTION
30	Duct air temperature sensor short circuit	Temperature sensor shorted to earth or failed	Check wiring and connections for shorting to earth
			Check sensor resistance
31	Duct air temperature sensor open circuit	Temperature sensor not connected or failed	Check wiring connections
			Check sensor continuity
34	Low mains supply voltage	Electrical supply fault to property	Check incoming mains supply
		Faulty wiring to appliance	Check wiring to appliance
43	Return air temperature short circuit	Temperature sensor shorted to	Check wiring connections not shorting to earth
			Check sensor resistance
44	Return air temperature sensor open circuit	Temperature sensor not connected or failed	Check wiring connections
			Check sensor continuity
45	Flue gas temperature sensor short circuit	Short circuit in wiring between sensor and control board	Check wiring to sensor
			Check electrical resistance of the sensor
46	Flue gas temperature sensor open circuit	Temperature sensor not connected or failed	Check wiring connections
			Check sensor continuity
57	Restricted airflow	Blocked filter and return air filter/ Duct	Check blockage from filter and return air filter/ducts
99	Communication MMI-ESYS lost	Connection between MMI & ESYS incorrectly made	Check wiring and connections

20. FAULT FINDING FLOW CHART

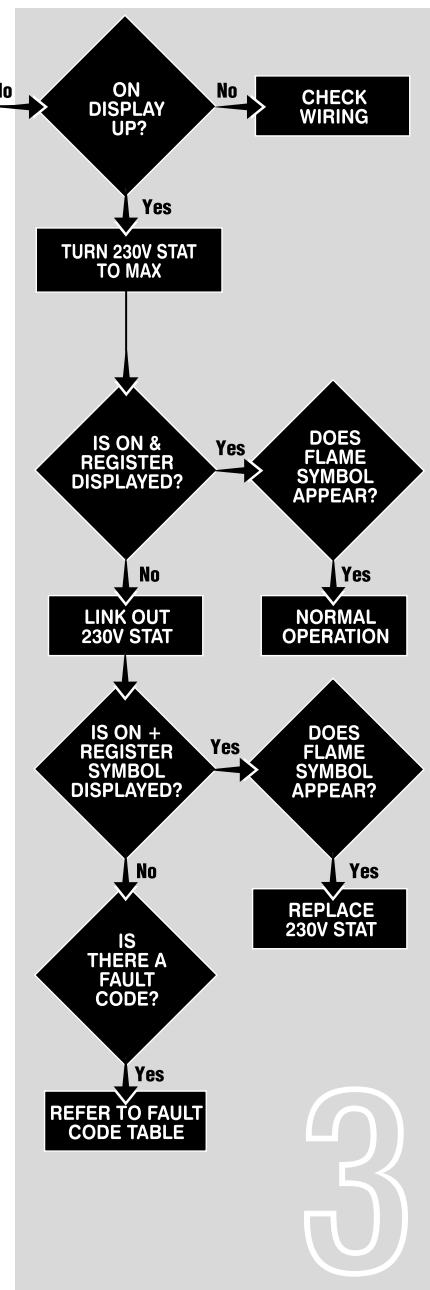
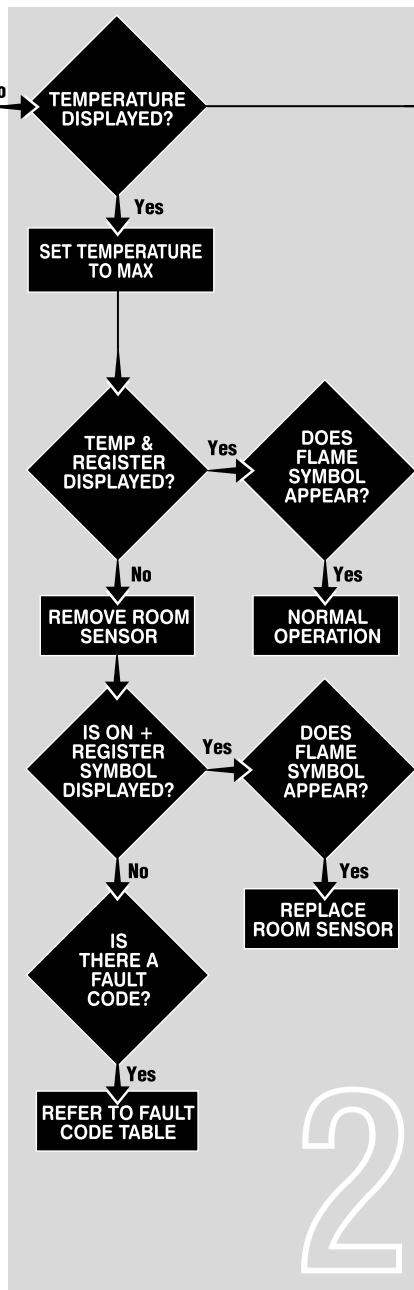
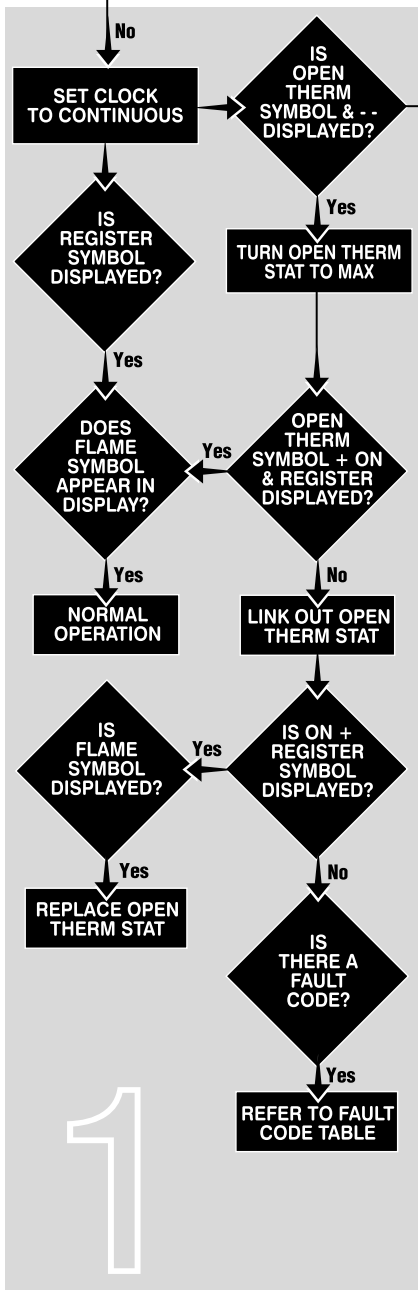
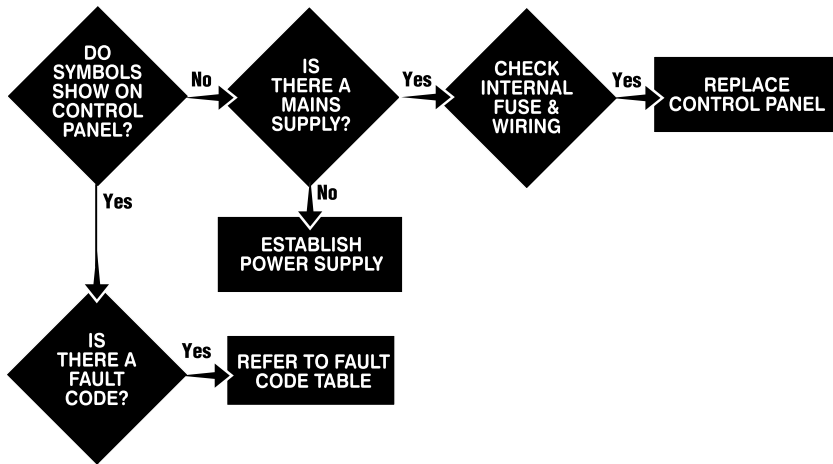

21. DEFECT DIAGNOSIS FOR THE CIRCULATION AIR FAN

21.1 CIRCULATION AIR FAN

21.1.1 Ensure Air Circulation Fan is running at maximum.

21.1.2 A voltage should be measured and blue (-) and yellow (+). Voltage approx. 10 VDC.

21.1.3 If voltage is present and fan is not running at maximum. Replace AFC.

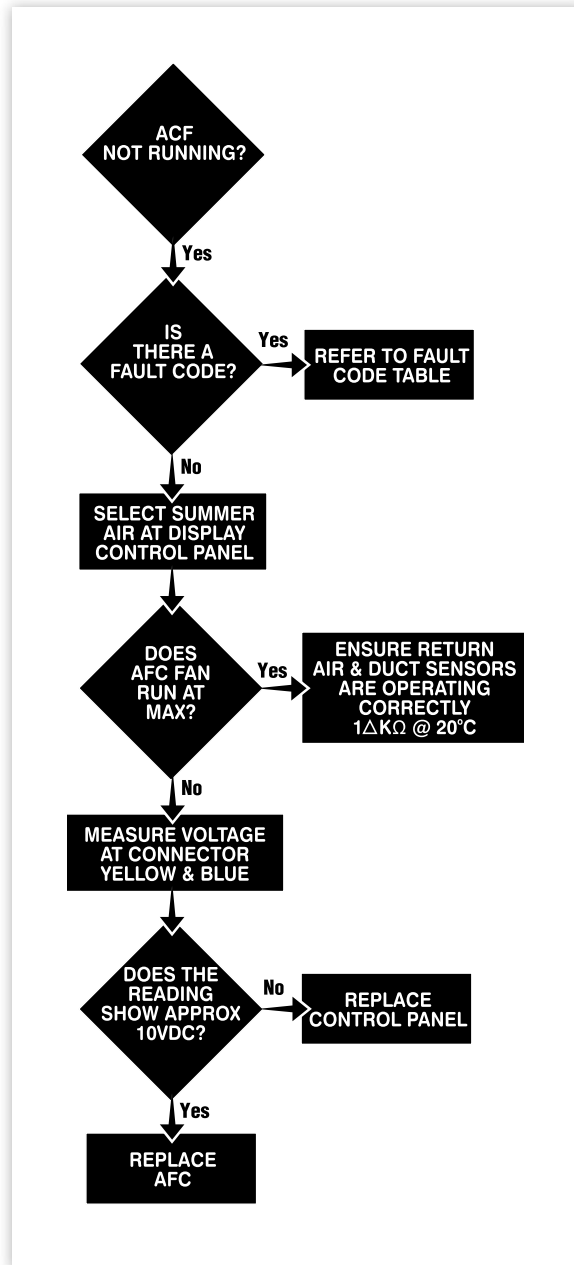

22. FUNCTIONAL WIRING DIAGRAMS

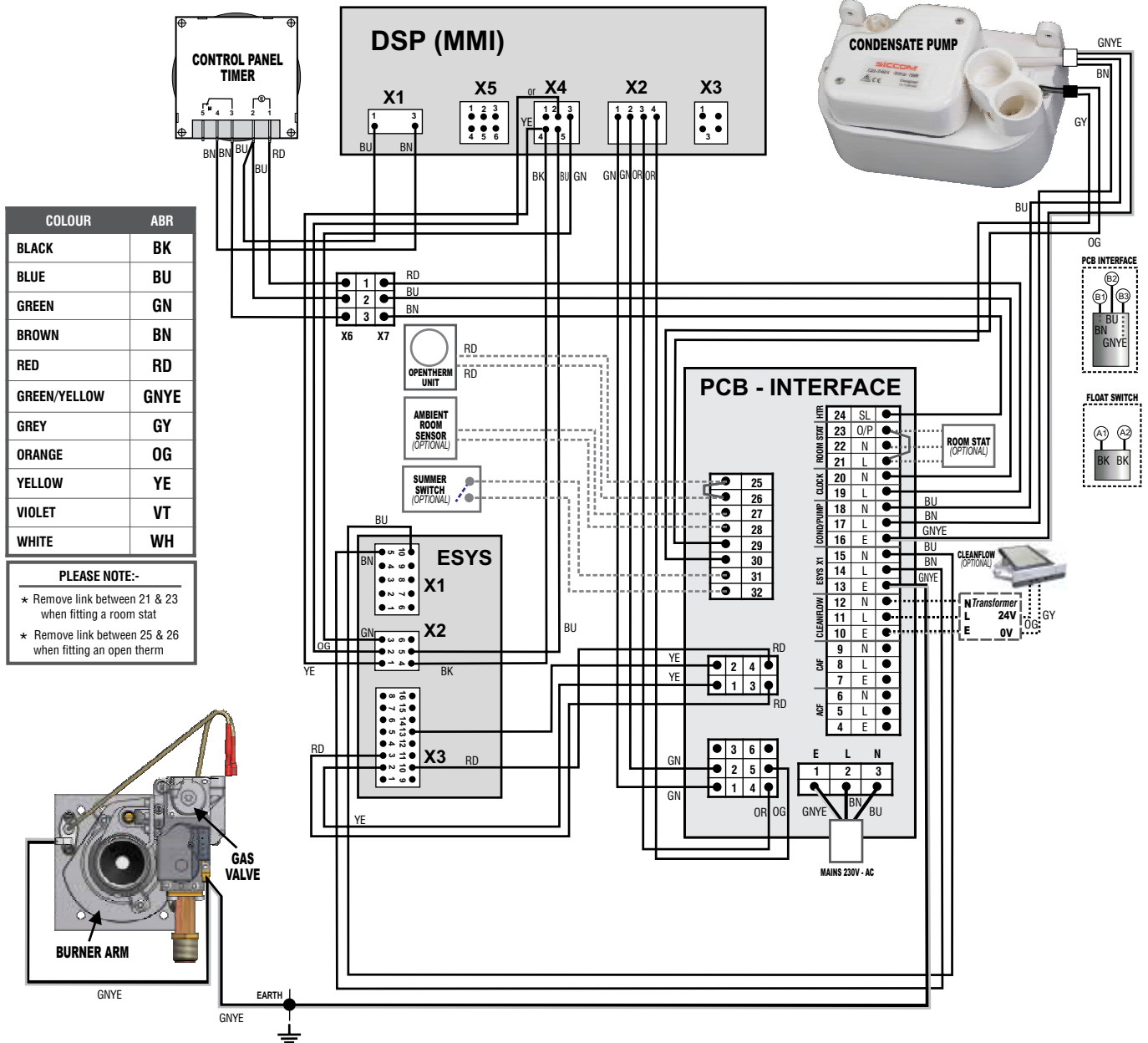

FIGURE 32. WIRING DIAGRAM No. 1 WIRING ROUTING TABLE

FROM UNIT	WIRE COLOUR	TERMINAL	L/N/E	TO UNIT	TERMINAL
TIMER	red	1	L	PCB INTERFACE	19
	blue	2	N	PCB INTERFACE	20
	blue	2		DSP (MMI)	X1 - 1
	brown	3		PCB INTERFACE	24
	brown	4		DSP (MMI)	X1 - 3
DSP (MMI)	green	X2 - 1		PCB INTERFACE	X2 - 1
	green	X2 - 2		PCB INTERFACE	X2 - 2
	orange	X2 - 3		PCB INTERFACE	X2 - 4
	orange	X2 - 4		PCB INTERFACE	X2 - 5
GAS VALVE	green/yellow	1	E	PCB INTERFACE	13
	green/yellow	1	E	ELECTRODE	
CLEANFLOW	orange	Transformer	E	PCB INTERFACE	10
	grey		L	PCB INTERFACE	11
	-		N	PCB INTERFACE	12
CONDENSATE PUMP	brown	X1 - 5		PCB INTERFACE	14
	blue	X1 - 10		PCB INTERFACE	15
	yellow	X2 - 1		DSP (MMI)	X4 - 4
	orange	X2 - 2		DSP (MMI)	X4 - 2
	green	X2 - 3		DSP (MMI)	X4 - 3
	black	X2 - 4		DSP (MMI)	X4 - 4
	blue	X2 - 5		DSP (MMI)	X4 - 5
	yellow	X3 - 2		PCB INTERFACE	X3 - 1
	red	X3 - 3		PCB INTERFACE	X3 - 3
	red	X3 - 10		PCB INTERFACE	X3 - 4
	yellow	X3 - 13		PCB INTERFACE	X3 - 2
	grey	A1		PCB INTERFACE	30
	orange	A2		PCB INTERFACE	29
blue	B3	N	PCB INTERFACE	18	
brown	B2	L	PCB INTERFACE	17	
green/yellow	B1	E	PCB INTERFACE	16	

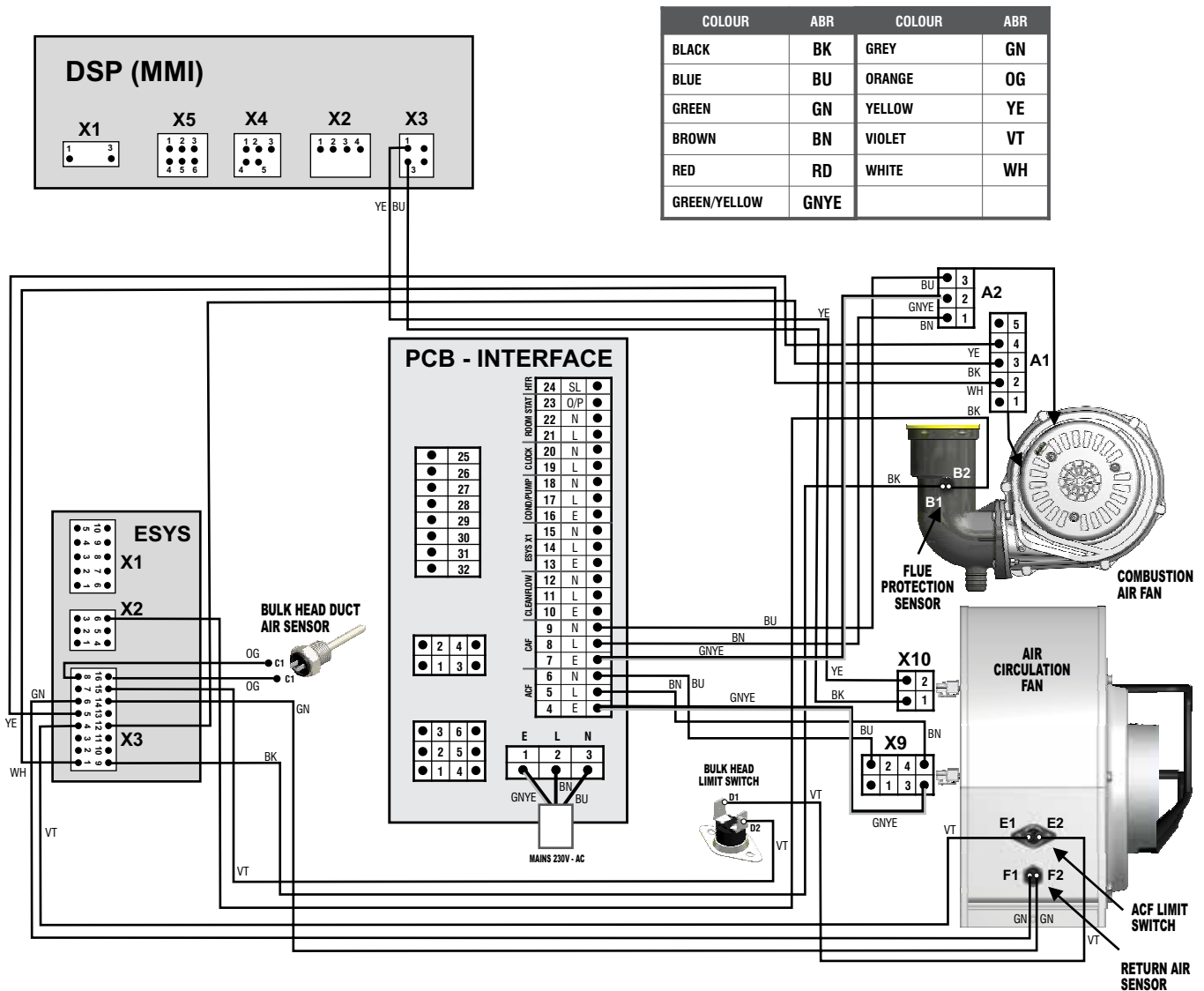

FIGURE 33. WIRING DIAGRAM No. 2 WIRING ROUTING TABLE

FROM UNIT	WIRE COLOUR	TERMINAL	L/N/E	TO UNIT	TERMINAL
COMBUSTION AIR FAN (CAF)	white	A1 - 2		ESYS	X3 - 1
	black	A1 - 3		ESYS	X3 - 12
	yellow	A1 - 4		ESYS	X3 - 5
	brown	A2 - 1	L	PCB INTERFACE	8
	green/yellow	A2 - 2	E	PCB INTERFACE	7
	blue	A1 - 3	N	PCB INTERFACE	9
CAF FLUE PROTECTION SENSOR	black	B1		ESYS	X3 - 9
	black	B2		ESYS	X2 - 6
BULKHEAD LIMIT SWITCH	purple	D1		ACF LIMIT SWITCH	E2
	purple	D2		ESYS	X3 - 15
BULKHEAD DUCT AIR SENSOR	orange	C1		ESYS	X3 - 8
	orange	C2		ESYS	X3 - 16
AIR CIRCULATION FAN (ACF)	blue	X9 - 2	N	PCB INTERFACE	6
	green/yellow	X9 - 3	E	PCB INTERFACE	4
	brown	X9 - 4	L	PCB INTERFACE	5
	black	X10 - 1		DSP (MMI)	X3 - 3
	yellow	X10 - 2		DSP (MMI)	X3 - 1
ACF LIMIT SWITCH	purple	E1		ESYS	X3 - 4
	purple	E2		BULKHEAD LIMIT SWITCH	D1
ACF RETURN AIR SENSOR	green	F1		ESYS	X3 - 6
	green	F2		ESYS	X3 - 14

23. DIMENSIONS

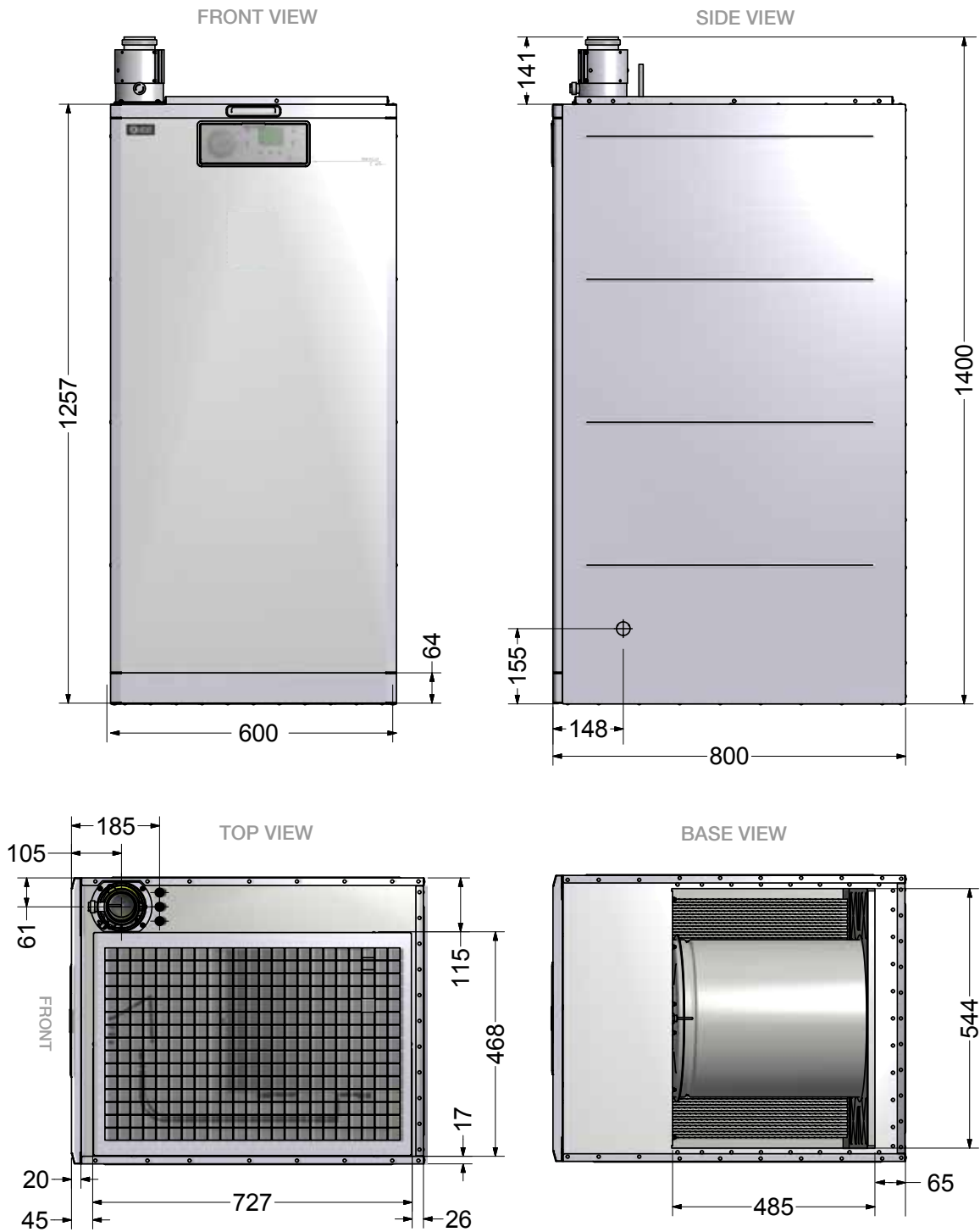

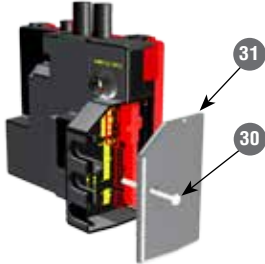



FIGURE 34. C36D DIMENSIONS

24. EXPLODED SPARES DIAGRAMS

ITEM	DESCRIPTION	QTY	PART No.	G. C. No.	
1	CONTROL PANEL ASSEMBLY	1	C10D-0501005		
2	COMBUSTION AIR FAN (CAF) ASSEMBLY <i>Includes 3 & 4</i>	1	1000-0525215	J24-837	
3	CAF GASKET SEALING RING	1	1000-1507860	H36-837	
4	CAF 'O' RING	1	1000-2501670	J24-909	
5	EXHAUST FLUE ELBOW ASSEMBLY <i>Includes 6 & 7</i>	1	1000-0022195	J24-836	
6	FLUE SEAL	1	1000-2501500	J24-833	
7	FLUE GAS SENSOR	1	1000-0522640	J24-836	
8	GAS VALVE/VENTURI <i>Includes 9 & 10</i>	1	1000-0710775	J24-776	
9	VENTURI GASKET	1	1000-1508280	J24-771	
10	CORK GASKET	2	1000-2501170	H38-674	
11	BURNER ARM ASSEMBLY <i>Includes 12 & 13</i>	1	1000-0710745		
12	BURNER GASKET A	1	1000-1508160	J24-765	
13	BURNER GASKET B	1	1000-1508170	J24-767	
14	IGNITION ELECTRODE ASSEMBLY <i>Includes 15</i>	1	1000-0710455	J24-780	
15	ELECTRODE GASKET	1	1000-2501270	J24-755	
16	DETECTION ELECTRODE ASSEMBLY <i>Includes 15</i>	1	1000-0710445	J24-769	

ITEM	DESCRIPTION	QTY	PART No.	G. C. No.	
17	AIR CIRCULATION FAN ASSEMBLY	1	C46D-0503005	J24-890	
18	FAN FAILURE SENSOR	1	1000-0517635		
19	RETURN AIR SENSOR DUCT TEMPERATURE SENSOR FLUE GAS SENSOR	1	1000-0522645	J24-833	
20	COMBUSTION AIR BOX ASSEMBLY <i>Includes 21 & 22</i>	1	C46D-0139005	J24-826	
21	SEALING RING	1	1000-2501680	J24-825	
22	CONNECTOR SEAL	1	1000-2501710		
23	CONDENSATE PUMP	1	1000-0025035		
24	HEAT EXCHANGER <i>Includes 21</i>	1	C46D-0330005		
25	ELECTRICAL P.C.B. BOARD <i>Includes 27</i>	1	1000-0526615	J24-838	
26	LOCKING CIRCUIT BOARD SUPPORTS	4	1000-0526480		

ITEM	DESCRIPTION	QTY	PART No.	G. C. No.	
27	HIGH LIMIT TEMPERATURE SENSOR	1	1000-0516835		
28	ESYS CONTROL BOX	1	1000-0526565	J24-898	
29	ESYS SCREW	1	1000-3004030	J24-855	
30	ESYS COVER	1	1000-0522610	J24-856	
31	CONDENSATE TRAP	1	1000-0024525	J24-749	
32	VERTICAL FLUE ADAPTER 60/100mm	1	1000-0022255	J24-784	
33	TELESCOPIC FLUE	1	1000-0022225	J24-811	
34	OPEN THERM SWITCH	1	1000-0525305		

26. LIST OF ANCILLARIES

	Description	Product Code	
1	CLEANFLOW AIR FILTER	CF36	
2	FILTER REPLACEMENT PADS <i>(Pack of 6)</i>	A0212X0212	
3	CLEANFLOW TRANSITION KIT	CTK36	
4	RETURN AIR KIT <i>Includes 4 & 5</i>	RAK36	
5	FLEXIBLE DUCTING	1000-0001390	
6	QUICK RELEASE DUCT CLIP	1000-0013770	
7	BASE DUCT	WB36	

Code Of Practice

For the installation, commissioning and servicing of domestic heating and hot water products

Benchmark places responsibilities on both manufacturers and installers.* The purpose is to ensure that customers** are provided with the correct equipment for their needs, that it is installed, commissioned and serviced in accordance with the manufacturer's instructions by competent persons and that it meets the requirements of the appropriate Building Regulations. Installers are required to carry out work in accordance with the following:

Standards of Work

- Be competent and qualified to undertake the work required.
- Install, commission, service and use products in accordance with the manufacturer's instructions provided.
- Ensure that where there is responsibility for design work, the installation is correctly sized and fit for purpose.
- Meet the requirements of the appropriate Building Regulations. Where this involves notifiable work be a member of a Competent Persons Scheme or confirm that the customer has notified Local Authority Building Control (LABC), prior to work commencing.
- Complete all relevant sections of the Benchmark Checklist/Service Record when carrying out commissioning or servicing of a product or system.
- Ensure that the product or system is left in a safe condition and, whenever possible, in good working order.
- Highlight to the customer any remedial or improvement work identified during the course of commissioning or servicing work.
- Refer to the manufacturer's helpline where assistance is needed.
- Report product faults and concerns to the manufacturer in a timely manner.

Customer Service

- Show the customer any identity card that is relevant to the work being carried out prior to commencement or on request.
- Give a full and clear explanation/demonstration of the product or system and its operation to the customer.
- Hand over the manufacturer's instructions, including the Benchmark Checklist, to the customer on completion of an installation.
- Obtain the customer's signature, on the Benchmark Checklist, to confirm satisfactory demonstration and receipt of manufacturer's instructions.
- Advise the customer that regular product servicing is needed, in line with manufacturers' recommendations, to ensure that safety and efficiency is maintained.
- Respond promptly to calls from a customer following completion of work, providing advice and assistance by phone and, if necessary, visiting the customer.
- Rectify any installation problems at no cost to the customer during the installer's guarantee period.



*The use of the word "installer" is not limited to installation itself and covers those carrying out installation, commissioning and/or servicing of heating and hot water products, or the use of supporting products (such as water treatment or test equipment).

**Customer includes householders, landlords and tenants.

WARM AIR HEATER AND CIRCULATOR COMMISSIONING CHECKLIST

This Commissioning Checklist is to be completed in full by the competent person who commissioned the warm air unit and associated equipment as a means of demonstrating compliance with the appropriate Building Regulations and then handed to the customer to keep for future reference.

Failure to install and commission this equipment to the manufacturer's instructions may invalidate the warranty but does not affect statutory rights.

Customer name:					Telephone number:				
Address:									
Warm Air Unit Make and Model									
Warm Air Unit Serial Number									
Commissioned by (PRINT NAME):					Gas Safe Reg. No.				
Company name:					Telephone number:				
Company address:									
					Commissioning date:				
To be completed by the customer on receipt of a Building Regulations Compliance Certificate*:									
Building Regulations Notification Number (if applicable)									
CONTROLS (tick the appropriate boxes if applicable)									
Time and temperature control to heating		Room thermostat and programmer/timer					Programmable Roomstat		
		Load/weather compensation					Optimum start control		
Time and temperature control to hot water		Cylinder thermostat and programmer/timer					Warm air unit		
Heating zone valves		Fitted					Not required		
Hot water zone valves		Fitted					Not required		
Thermostatic radiator valves		Fitted					Not required		
Automatic bypass system		Fitted					Not required		
Warm Air Unit Interlock		Yes		No		If YES	Volume:		Litres
FOR WARM AIR HEATERS ONLY									
Has the system been balanced in accordance with the heater manufacture's instructions?							Yes		No
Was an anemometer used?							Yes		No
Have balancing dampers been fitted?							Yes		No
FOR WARM AIR HEATING: MEASURE AND RECORD									
Burner operating pressure									mbar
Heat input									kW
Temperature difference between return air inlet and nearest outlet									°C
FOR HOT WATER GENERATORS: measure and record									
Burner operating pressure									mbar
Heat input									kW
Water flow temperature									°C
ALL INSTALLATIONS									
The heating and hot water system complies with the appropriate Building Regulations								Yes	
The system and associated products have been installed and commissioned in accordance with the manufacturer's instructions								Yes	
The efficient operation of system and its controls have been demonstrated to and understood by the customer								Yes	
The manufacturer's literature, including Benchmark Checklist and Service Record, has been explained and left with the customer								Yes	
Commissioning Engineer's Signature									
Customer's Signature									
(To confirm demonstration of equipment and receipt of appliance instructions)									

*All installations in England and Wales must be notified to Local Authority Building Control (LABC) either directly or through a Competent Persons Scheme. A Building Regulations Compliance Certificate will then be issued to the customer.



SERVICE RECORD

It is recommended that your heating system is serviced regularly and that the appropriate Service Interval Record is completed.

Service Provider

Before completing the appropriate Service Record below, please ensure you have carried out the service as described in the manufacturer's instructions. Always use the manufacturer's specified spare part when replacing controls.

SERVICE 01					Date:						
Engineer name:											
Company name:											
Telephone No:											
Gas safe register No:											
Record:	At max. rate:	CO	ppm	AND	CO ₂ %	Record:	At max. rate:	CO	ppm	AND	CO ₂ %
	At min. rate: (Where Possible)	CO	ppm	AND	CO ₂ %		At min. rate: (Where Possible)	CO	ppm	AND	CO ₂ %
Comments:											
Signature											

SERVICE 02					Date:						
Engineer name:											
Company name:											
Telephone No:											
Gas safe register No:											
Record:	At max. rate:	CO	ppm	AND	CO ₂ %	Record:	At max. rate:	CO	ppm	AND	CO ₂ %
	At min. rate: (Where Possible)	CO	ppm	AND	CO ₂ %		At min. rate: (Where Possible)	CO	ppm	AND	CO ₂ %
Comments:											
Signature											

SERVICE 03					Date:						
Engineer name:											
Company name:											
Telephone No:											
Gas safe register No:											
Record:	At max. rate:	CO	ppm	AND	CO ₂ %	Record:	At max. rate:	CO	ppm	AND	CO ₂ %
	At min. rate: (Where Possible)	CO	ppm	AND	CO ₂ %		At min. rate: (Where Possible)	CO	ppm	AND	CO ₂ %
Comments:											
Signature											

SERVICE 04					Date:						
Engineer name:											
Company name:											
Telephone No:											
Gas safe register No:											
Record:	At max. rate:	CO	ppm	AND	CO ₂ %	Record:	At max. rate:	CO	ppm	AND	CO ₂ %
	At min. rate: (Where Possible)	CO	ppm	AND	CO ₂ %		At min. rate: (Where Possible)	CO	ppm	AND	CO ₂ %
Comments:											
Signature											

SERVICE 05					Date:						
Engineer name:											
Company name:											
Telephone No:											
Gas safe register No:											
Record:	At max. rate:	CO	ppm	AND	CO ₂ %	Record:	At max. rate:	CO	ppm	AND	CO ₂ %
	At min. rate: (Where Possible)	CO	ppm	AND	CO ₂ %		At min. rate: (Where Possible)	CO	ppm	AND	CO ₂ %
Comments:											
Signature											

SERVICE 06					Date:						
Engineer name:											
Company name:											
Telephone No:											
Gas safe register No:											
Record:	At max. rate:	CO	ppm	AND	CO ₂ %	Record:	At max. rate:	CO	ppm	AND	CO ₂ %
	At min. rate: (Where Possible)	CO	ppm	AND	CO ₂ %		At min. rate: (Where Possible)	CO	ppm	AND	CO ₂ %
Comments:											
Signature											

SERVICE 07					Date:						
Engineer name:											
Company name:											
Telephone No:											
Gas safe register No:											
Record:	At max. rate:	CO	ppm	AND	CO ₂ %	Record:	At max. rate:	CO	ppm	AND	CO ₂ %
	At min. rate: (Where Possible)	CO	ppm	AND	CO ₂ %		At min. rate: (Where Possible)	CO	ppm	AND	CO ₂ %
Comments:											
Signature											

SERVICE 08					Date:						
Engineer name:											
Company name:											
Telephone No:											
Gas safe register No:											
Record:	At max. rate:	CO	ppm	AND	CO ₂ %	Record:	At max. rate:	CO	ppm	AND	CO ₂ %
	At min. rate: (Where Possible)	CO	ppm	AND	CO ₂ %		At min. rate: (Where Possible)	CO	ppm	AND	CO ₂ %
Comments:											
Signature											

SERVICE 09					Date:						
Engineer name:											
Company name:											
Telephone No:											
Gas safe register No:											
Record:	At max. rate:	CO	ppm	AND	CO ₂ %	Record:	At max. rate:	CO	ppm	AND	CO ₂ %
	At min. rate: (Where Possible)	CO	ppm	AND	CO ₂ %		At min. rate: (Where Possible)	CO	ppm	AND	CO ₂ %
Comments:											
Signature											

SERVICE 10					Date:						
Engineer name:											
Company name:											
Telephone No:											
Gas safe register No:											
Record:	At max. rate:	CO	ppm	AND	CO ₂ %	Record:	At max. rate:	CO	ppm	AND	CO ₂ %
	At min. rate: (Where Possible)	CO	ppm	AND	CO ₂ %		At min. rate: (Where Possible)	CO	ppm	AND	CO ₂ %
Comments:											
Signature											

*All installations in England and Wales must be notified to Local Authority Building Control (LABC) either directly or through a Competent Persons Scheme. A Building Regulations Compliance Certificate will then be issued to the customer.





sustainable solutions
under one roof

Johnson & Starley Ltd

Rhosili Road, Brackmills,
Northampton NN4 7LZ

sales@johnsonandstarley.co.uk

marketing@johnsonandstarley.co.uk

Reception/Customer Service

01604 762881

Fax

01604 767408

