

# WARMCAIR C16D

## Condensing Air Heater

High Efficiency Downflow  
Condensing Air Heater



INSTALLATION,  
COMMISSIONING  
& SERVICING INSTRUCTIONS

WarmCair C16D - G.C. No. 42-415-19

These instructions are to be left with the User



FM 525200



Johnson  
& Starley

Johnson & Starley Ltd  
Rhosili Road  
Brackmills, Northampton  
NN4 7LZ



# CONTENTS

The Benchmark Scheme	3	15 Handing Over	18
1 Features	4	16 Servicing & Maintenance	19
2 General Description	4	<i>Servicing Schedule</i>	
3 Building Standards & Regulations	5	<i>Servicing Sequence</i>	
4 Safety & Gas Information	6	<i>Component Checklist</i>	
<i>General Safety Information</i>		<i>Gaining Access for Servicing</i>	
<i>Gas Categories</i>		<i>Main Burner Assembly</i>	
<i>Gas Supply</i>		<i>Ignition &amp; Flame Detection Electrode</i>	
5 Technical Data	6	<i>Heat Exchanger/Combustion Chamber</i>	
6 Heater Positioning	7	<i>Combustion Air Fan</i>	
7 Heater Compartment Clearances	7	<i>Air Circulations Fan</i>	
8 Duct System	8	<i>Condensate Drain Piped</i>	
<i>Return Air</i>		<i>Condensate Pump</i>	
<i>Warm Air Delivered</i>		17 Parts Replacements	23
9 Flue Instructions	9	<i>Control Panel</i>	
<i>Flue Configuration</i>		<i>Air Circulation Fan</i>	
<i>Diagram of Terminal Position</i>		<i>Return Air Temperature Sensor</i>	
<i>Types of Flue Systems</i>		<i>Flue Temperature Sensor</i>	
<i>Plume Terminal Outlets</i>		<i>High Limit Temperature Sensor</i>	
<i>Flue Requirements &amp; General Information</i>		<i>Air Pressure Switch</i>	
<i>Conventional 60/100mm Flue Accessories Part No's</i>		<i>Condensate Drain Pump</i>	
<i>Optional Roof Outlets</i>		<i>Main Ignition/Control PCB</i>	
<i>The Extended Horizontal Flue System</i>		<i>Gas Valve &amp; Venturi Assembly</i>	
11 Condensate Pump & Drain Tube	14	<i>Burner Assembly</i>	
<i>Condensate Pump</i>		<i>Ignition Electrodes</i>	
<i>Technical Data</i>		<i>Flame Detection Electrodes</i>	
<i>Condensate Tube Routing Options</i>		<i>Combustion Air Fan</i>	
11 Gas	15	18 Control Panel Modes	26
12 Electrical	15	19 Fault Code & Blocking Code Table	27
<i>Mains Supply</i>		20 Fault Finding Flowcharts	28
<i>Thermista-stat &amp; It's Location</i>		21 Defect Diagnosis for the	30
13 Fitting Instructions	16	Circulation Air Fan	
14 Commissioning	16	22 Functional Wiring Diagrams	31
<i>System Balancing</i>		23 Dimensions	32
<i>Lighting the Main Burner</i>		24 List of Spares	34
<i>Gas Rate Check</i>		25 Important Information	37
		26 Code of Practice	38
		27 Benchmark Checklist	49
		and Service Record	

PLEASE READ THESE INSTRUCTIONS CAREFULLY BEFORE STARTING INSTALLATION.  
LEAVE THESE INSTRUCTION WITH THE USER OR AT THE GAS METER AFTER  
INSTALLATION



## The Benchmark Scheme

Benchmark places responsibilities on both manufacturers and installers. The purpose is to ensure that customers are provided with the correct equipment for their needs, that it is installed, commissioned and serviced in accordance with the manufacturer's instructions by competent persons and that it meets the requirements of the appropriate Building Regulations. The Benchmark Checklist can be used to demonstrate compliance with Building Regulations and should be provided to the customer for future reference.

Installers are required to carry out installation, commissioning and servicing work in accordance with the Benchmark Code of Practice which is available from the Heating and Hotwater Industry Council who manage and promote the Scheme.

Visit [www.centralheating.co.uk](http://www.centralheating.co.uk) for more information.

In the interest of continuous development Johnson and Starley reserve the right to change specification without prior notice. Johnson and Starley prides itself on it's ability to supply spare parts quickly and efficiently.

## 1. FEATURES

### Appliance Classification:

The WarmCair C16D has been tested and CE certified by B.S.I Ltd for use with NATURAL gas G20.

### FEATURES

1. Flue Adapter
2. Combustion Measuring Point
3. Time Control
4. PCB Control Wiring Panel
5. Sliding Flue Connector
6. Flue Collector Box
7. Flue Sensor
8. Condense Outlet
9. Inspection Glass
10. Condense Trap Assembly
11. Condensing Pump Outlet Pipe Hose
12. Condense Pump
13. Duct Temperature Sensor
14. Condense Pump Filter
15. Gas Cock
16. ESYS
17. Gas valve
18. Ignition & Detection Electrode Leads
19. High Limit Temperature Sensor
20. Combustion Air fan Assembly
21. Return Air Sensor
22. Fan Failure Sensor
23. Air Circulation Fan
24. MMI Control Panel
25. Return Air Filter

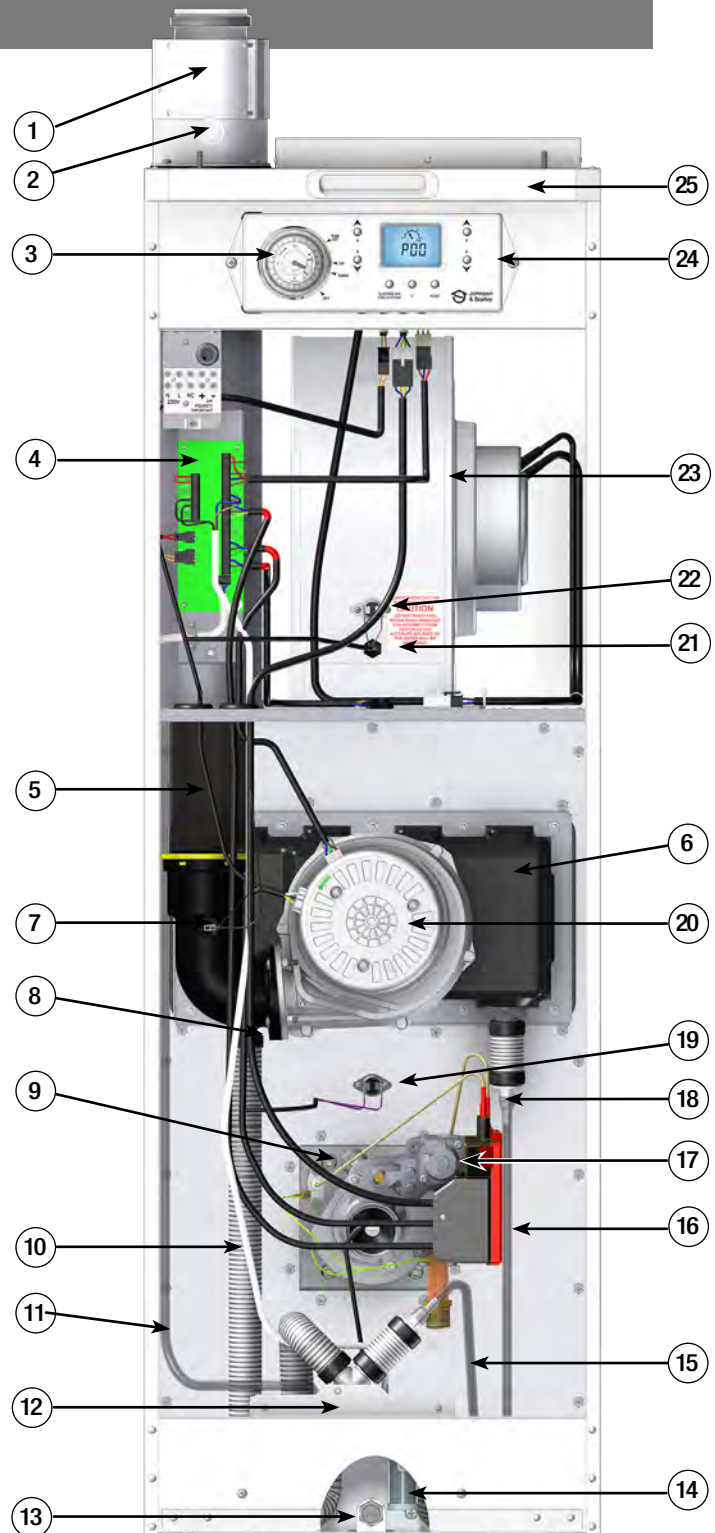


FIGURE 1. C16D FEATURES

## 2. BRIEF DESCRIPTION

2.1 The WarmCair C16D is a highly efficient condensing gas fired downflow forced convection air heater. Significant reductions in Low Carbon and NOx emissions are achieved.

It has been designed to provide the user with on demand Warm Air Central Heating. Using sophisticated controls enabling it to provide the precise amount of heat output to match demand. It is room sealed, with a stainless steel heat exchanger, using a vertical or horizontal Concentric Flue System.

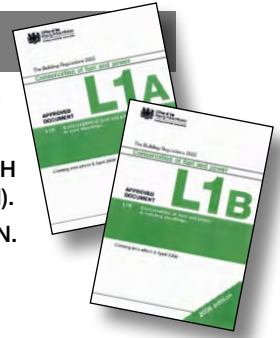
The Warmcair C16D air heater is ideally suited for new built dwellings and the replacement of existing non-condensing air heaters.

2.2 The air heater output modulates 14.08kW (31.68MJ/h, 30,026 Btu/h) down to 4.4kW (15.84MJ/h, 15,013Btu/h) "Summer Air Circulation" of unheated air is available by manual selection (see the user's instructions).

### 3. BUILDING STANDARDS & REGULATIONS



STATUTE LAW DEFINES THAT ALL GAS APPLIANCES MUST BE INSTALLED BY COMPETENT PERSONS, i.e. GAS SAFE REGISTERED INSTALLERS.  
GAS SAFE MEMBERSHIP ENQUIRIES TEL: 0800 408 5500 IN ACCORDANCE WITH THE GAS SAFETY (INSTALLATION AND USE) REGULATIONS (CURRENT EDITION).  
FAILURE TO COMPLY WITH THESE REGULATIONS MAY LEAD TO PROSECUTION.



#### 3.1 INSTALLATION REGULATIONS

- Gas Safety (Installation and Use) Regulations (as amended)
- Model and Local Authority Byelaws
- Health & Safety Document No. 635.
- The Electricity at Work Regulations
- Institute of Electrical Engineers (I.E.E) Wiring Regulations
- British System Design Manual "Gas Fired Warm Air Heating"
- EN Regulations No. 1196 Supplementary Instructions - Condensing Air Heaters

#### 3.2 BUILDING STANDARDS AND REGULATIONS

Where no specific instructions are given, reference should be made to the relevant British Standard Code of Practice.

Building Standards (Scotland) (Consolidation) Regulations

Building Regulation (Northern Ireland)

Building Regulations Part L

- BS 6891 Installation of Low Pressure Gas Pipework of up to 28mm (R1) in domestic premises (2nd family gases).
- BS 5440:1 Flues (for gas appliances of rated input not exceeding 70 kW).
- BS 5440:2 Ventilation (for gas appliances of rated input not exceeding 70 kW).
- BS 5864 Installation of Gas Fired Ducted Air Heaters

**IMPORTANT:** This appliance is CE certificated for safety and performance. It is important that no modifications are made to this appliance, unless fully approved in writing by Johnson & Starley Ltd. If in doubt please ring Johnson & Starley Ltd on Telephone 01604 762881.

## GAS LEAKS



DO NOT OPERATE ANY ELECTRICAL SWITCHES, OR USE A NAKED FLAME TURN OFF THE GAS SUPPLY. VENTILATE THE AREA BY OPENING DOORS AND WINDOWS.

CALL THE NATIONAL GAS EMERGENCY SERVICE ON  
0800 111999

## 4. SAFETY & GAS INFORMATION

### PLEASE READ THESE INSTRUCTIONS CAREFULLY BEFORE COMMENCING WITH THE INSTALLATION

#### 4.1 GENERAL SAFETY INFORMATION

- 4.1.1 Ensure the mains supply voltage, frequency, number of phases and power rating comply with details on the rating label.
- 4.1.2 All wiring must be in accordance with the appropriate standards. The equipment must be supplied with a double pole isolator switch.
- 4.1.3 Ensure safety regulations and practices are adhered to when installing and using this equipment.
- 4.1.4 The weight of this appliance exceeds that recommended for a one-man lift. It will therefore be necessary to gain assistance at times during the installation procedure.
- 4.1.5 It should be noted that this appliance may contain sharp edges. Care MUST be taken when handling the appliance to prevent injury.
- 4.1.6 Once the appliance has been fired beware that certain parts will be hot to the touch.
- 4.1.7 Do not install flues during rain, high winds or in severe weather conditions.

#### 4.2 GAS INFORMATION

##### 4.2.1 Gas Categories

- a. The appliance is certified as a CAT I 2H (20) appliance.

##### 4.2.2 Gas Supply

- a. The gas installation must be completed in accordance with the relevant standards (BS 6891).
- b. The supply must be capable of providing a steady inlet working pressure to the appliance of 20 mbar at a rate of 1.94m<sup>3</sup>/h or 52.64ft<sup>3</sup>/h (Calculated with a Gas C of 38.7MJ/m<sup>3</sup>)
- c. The installation must be tested for gas tightness using suitable methods. The Pipework should also be purged of air in accordance with the IG Publication Standard.

## 5. TECHNICAL DATA

		<b>C16D</b>				
<b>WEIGHT</b>	62kg					
<b>GAS</b>	G20					
<b>GAS SUPPLY PRESSURE</b>	20mbar					
<b>GAS CATEGORY</b>	I 2H					
<b>COUNTRIES OF INSTALLATION</b>	GB & IE					
<b>ELECTRICAL SUPPLY</b>	230V ~ 50Hz fused 5A 215W					
<b>ELECTRIC POWER CONSUMPTION</b>	100 W (at rated heating capacity), 27 W (at minimal cap.), 5 W (standby mode)					
<b>USEFUL EFFICIENCY</b>	88 % (at rated heating capacity), 98 % (at minimum capacity)					
<b>ENVELOPE LOSS FACTOR</b>	0					
<b>IGNITION BURNER POWER CONSUM.</b>	0 W					
<b>EMISSIONS OF NITROGEN OXIDES</b>	64 mg / kWh					
<b>EMISSION EFFICIENCY</b>	87.52 %					
<b>SEASONAL SPACE HEATING ENERGY EFFIC.</b>	76.2 %					
	MAXIMUM			MINIMUM		
	kW	MJ/h	Btu/h	kW	MJ/h	Btu/h
<b>INPUT (GROSS)</b>	16.0	57.6	54,592	5.0	18.0	17,060
<b>OUTPUT</b>	14.08	31.68	48,041	4.4	15.84	15,013
<b>GAS RATE CV 1037Btu/FT<sup>3</sup></b>	1.94m <sup>3</sup> /h (52.64ft <sup>3</sup> /h)			0.466m <sup>3</sup> /h (16.45ft <sup>3</sup> /h)		
<b>BURNER % CO<sup>2</sup></b>	9 ± 1			8 ± 1		

TABLE 1. C16D TECHNICAL DATA

## 6. HEATER POSITIONING

- 6.1 This heater is not suitable for external installation unless it is protected from the elements by a suitable enclosure. The enclosure must provide the clearance for installation, servicing and maintenance as well as the correct level of ventilation. The selected position should allow for a suitable flue system to be installed.
- 6.2 When installed in a timber frame building guidance should be taken from the Gas Industry Publication IGE/UP-7 (Guide for Gas Installations in Timber Frame Housing).
- 6.3 BS 6798 gives details of the essential features for a compartment or cupboard where a gas appliance is to be installed. An existing cupboard may require modifications.
- 6.4 If the heater is installed in a room containing a bath or shower it is important to locate the electrical switch in a position where it cannot be touched by anyone using the bath or shower. The current IEE Wiring Regulations (BS 7671) for England and electrical provision of the Building Regulations for Scotland gives details.
- 6.5 Room ventilation for the heater is not necessary as the heater draws its combustion air from the outside of the building, cupboard or compartment ventilation is not necessary providing that the minimum clearances are maintained. However, reference should be made to BS 5440 Pt. 2.

**IMPORTANT:** This appliance must be completely level. It MUST NOT lean in any direction. Otherwise it will cause problems with the condense draining.

## 7. HEATER COMPARTMENT CLEARANCES *(see BS 5864)*

- 7.1 **IMPORTANT** - If the heater is to be fitted to an existing base duct (warm air plenum), always ensure when installing the appliance, the rear of the heater is aligned with the rear of the base duct. If there is any overhang or blanking off it will be at the front of the heater. In any event, blanking plates must be mechanically secured and all joints sealed.
- 7.2 When the heater is fitted into a compartment, a minimum clearance from the compartment walls of 3mm (1/8") at the sides, rear and front must be left. Where clearances are less than 75mm, internal surface must be lined with non-combustible material and the compartment must be of a fixed rigid structure. However, there is no requirement for the use of non-combustible material at the front of the unit. Consideration should also be given to the space required for the removal and replacement of the filter tray and the entry of the gas and electrical supplies. If gas connections are made from a side entry, a minimum clearance of 75mm (3") is required at that side.
- 7.3 For service access, a minimum of 450mm (18") is required at the front of the heater. Space must also be allowed, in a compartment installation, to permit the removal of the heater.
- 7.4 In airing cupboard installations, the part used as the air heater compartment must comply with the relevant section of BS 5864 and must be completely separated by either a non-combustible partition or a perforated metal partition with the perforations not exceeding 13mm (1/2"). The secondary flue must be a tight fit where it passes through the partition and must be suitably protected See BS 5440: Part .
- 7.5 In under-stairs installations, the compartment must comply with the relevant section of BS 5864, provided that in addition all internal surfaces (including the base) are non-combustible or lined with non-combustible material. This requirement is applicable only to dwellings of more than two storeys.
- 7.6 In free-standing installations, (Refer to the instructions packed with top closure kit), only one or two walls will be in close proximity to the air heater; these must be non-combustible.
- 7.7 Where the air heater is to be installed onto a combustible surface and under-floor ducting used, a suitable base tray MUST be used in order to provide insulation.  
NB where a base plenum is used no base tray is required!
- 7.8 Although two permanent ventilation openings are not required, consideration should be given to the amount of heat emitted by any ductwork present in the compartment, otherwise the compartment temperature could increase and will affect the safe operation of the appliance and its controls.

## **8. DUCT SYSTEM** (See British Design Manual - Gas fired Warm Air Heating)

### **8.1 RETURN AIR**

- 8.1.1 A room-sealed heater can be installed without positive return air ducting, provided that the path between the return air grille and the heater return air inlet is protected in such a manner that the required airflow is maintained at all times (BS5864).
- 8.1.2 The return air grille **MUST** have a free area of not less than 900 cm<sup>2</sup> (140 in<sup>2</sup>). It is recommended that the return air duct not be routed directly from the main living area, but from a convenient central area serving the remainder of the dwelling.
- 8.1.3 The return air system should be constructed of fire-resistant material where used. It is extremely important that the correct size of return air grilles and ducting is used. The return air duct area should not be less than 450 cm<sup>2</sup> (70 in<sup>2</sup>). If flexible duct is used the duct diameter should not be less than 300 mm (12") diameter.
- 8.1.4 An adequate and unobstructed return air path is essential from areas not served by a directly ducted return and to which warm air is delivered. All such rooms should be fitted with relief grilles which have a free area of 0.0088 m<sup>2</sup>/kW (1 in<sup>2</sup>/250 Btu/h) of heat supplied to the room. The only exceptions are kitchens, bathrooms and WCs.
- 8.1.5 The return air duct should allow for ease of removal for access to the flue.
- 8.1.6 All duct work in the room or internal space in which the heater is installed shall be mechanically secured and sealed with ducting tape.
- 8.1.7 If a return air duct is not to be fitted, the top of the unit must be suitably guarded to prevent blockage

### **8.2 WARM DELIVERED AIR**

- 8.2.1 All duct work, including riser ducts, should be fully insulated with 50mm (2") fibre-glass or similar. If short extended duct runs are taken below floor level these should be similarly insulated and in addition wrapped with a sound vapour proof barrier. They must also be protected from crushing.
- 8.2.2 The duct system should be carefully designed (as given in the guidelines in the British System Design Manual) to suit the needs of specific heating requirements and building layout. The type of duct system (e.g. radial/extended plenum/ stepped) should be installed using the least number of fittings to minimise airflow resistance. The base duct, which equalises the air pressure to supply ducts, must be constructed to support the weight of the heater, which must be sealed using self-adhesive foam strip, ducting tape or sealing compound. All ducting and blanking plates must be mechanically secured and sealed.



## 9. FLUE INSTRUCTIONS

- 9.1 The WarmCair C16D Condensing Air Heater is certified as a warm air heater with corresponding flue systems according to EU Directive 2009/142/EC on gas-fired devices. These installation instructions are covered by this certification and are referred to in the design approval test certificate.
- 9.2 The installation of the warm air heater and flue system must be in accordance with the Gas Safety (Installation and Use) Regulations 1998 and the Building Regulations. If no specific instructions are given, reference should be made to the relevant codes of practice.

### THESE RELEVANT STANDARDS SHOULD BE FOLLOWED

**BS 5440:1** Flues and ventilation for gas appliances of rated heating input not exceeding 70kW (net) : Flues

**BS 5440:2** Flues and ventilation for gas appliances of rated heating input not exceeding 70kW (net) : Air Supply  
Ensure all legislation, regulations and directives mentioned are observed.

- 9.3 The air/flue duct operates at very low temperatures therefore no clearance is necessary between the air duct and the adjacent services.
- 9.4 Ensure while installation work is being carried out that no debris such as swarf, filings or fragments of mortar are allowed to remain in the air/flue duct.

### 9.5 FLUE CONFIGURATIONS

**NOTE:** Vertical Appliance adaptor is fitted as part of the air heater.

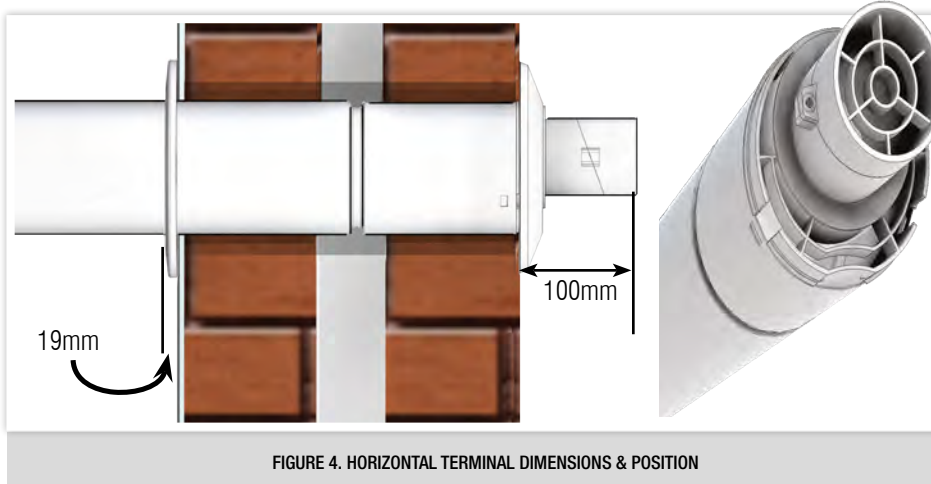
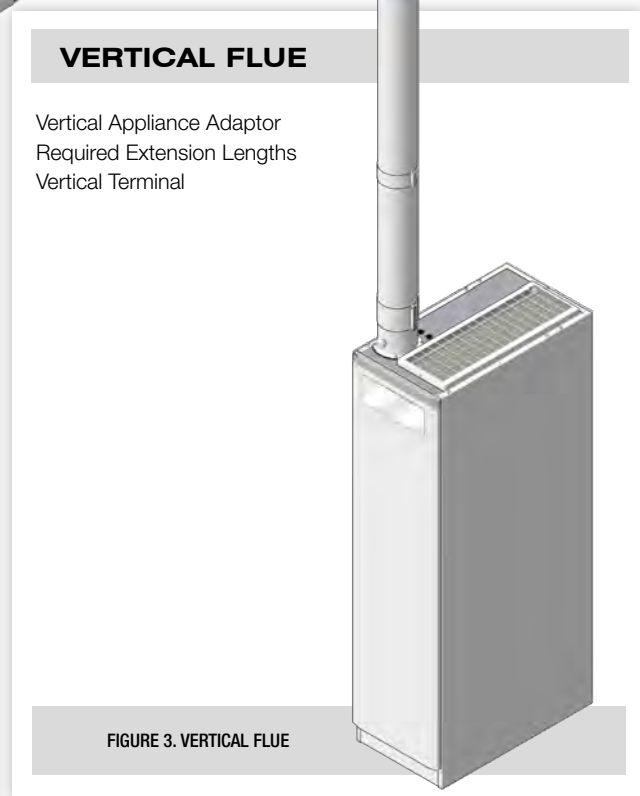
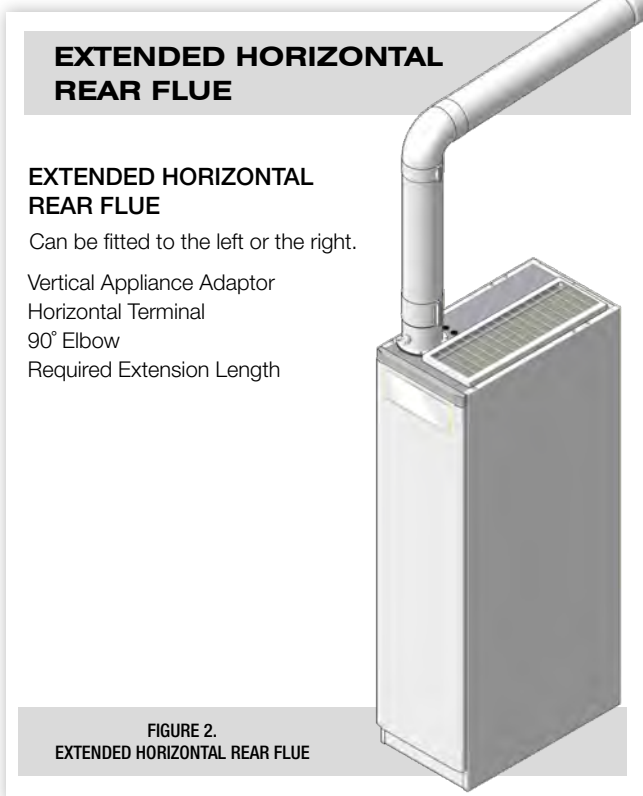




FIGURE 5. TERMINAL POSITIONS

	TERMINAL POSITION	MINIMUM DISTANCE
A	Directly below an opening, air brick, opening window etc	300mm
B	Above an opening, air brick, opening window, etc.	300mm
C	Horizontally to an opening, air brick, opening window etc.	300mm
D	Below gutters, soil pipes or drain pipes.	75mm
E	Below eaves.	200mm
F	Below balconies.	200mm
G	From a vertical drain pipe or soil pipe.	150mm
H	From an internal or external corner. Greater than 450mm protrusion.	300mm
I	Above ground, roof or balcony level.	300mm
J	From a surface facing the terminal.	600mm
K	From a terminal facing the terminal.	1,200mm
M	Vertically from a terminal on the same wall.	1,500mm
N	Horizontally from a terminal on the same wall.	300mm
Q	Above intersection with roof.	530mm
P	From a vertical structure on the roof	300mm
R	From the terminal to the boundary	300mm

TABLE 2. TERMINAL DIMENSIONS

## 9.6 TYPE OF FLUE SYSTEMS

Two types of flue systems are available for the C16D.

- i) The standard concentric flue system 60/100mm (100mm diameter)
- ii) A Flexible flue kit (FFK) 60/100mm (100mm diameter) For further information contact the sales office at Johnson & Starley Ltd. Telephone 01604 762881

## 9.7 FLUE TERMINAL POSITIONS

9.7.1 The following information provides the general requirements for siting flue terminals. As part of the recommendation given in BS 1550 Part 1. For IE recommendations, see the current issue of I.S. 813 "Domestic Gas Installations." Also publication a "Guide for Gas Installations in Timber Framed Housing DM2" or consult your local gas region, They MUST be consulted when installing the appliance into a timber-framed building.

**NOTE:** Due to the nature of the warm air heater, water vapour will discharge from the flue. This should be taken into account when siting the flue

9.7.2 Both the extended horizontal and vertical terminals must be positioned on the outside of the building and the free passage of air must be available at all times. It is not recommended to position the terminal close to projections especially under a balcony or near to a drainpipe. See Figure 3.

9.7.3 Ensure that combustion products cannot enter the building where the heater is installed or near to any other building where doors or windows may be open.

9.7.4 Recommended terminal positions for both extended horizontal and vertical flues are shown and flue components and installation options are also detailed.

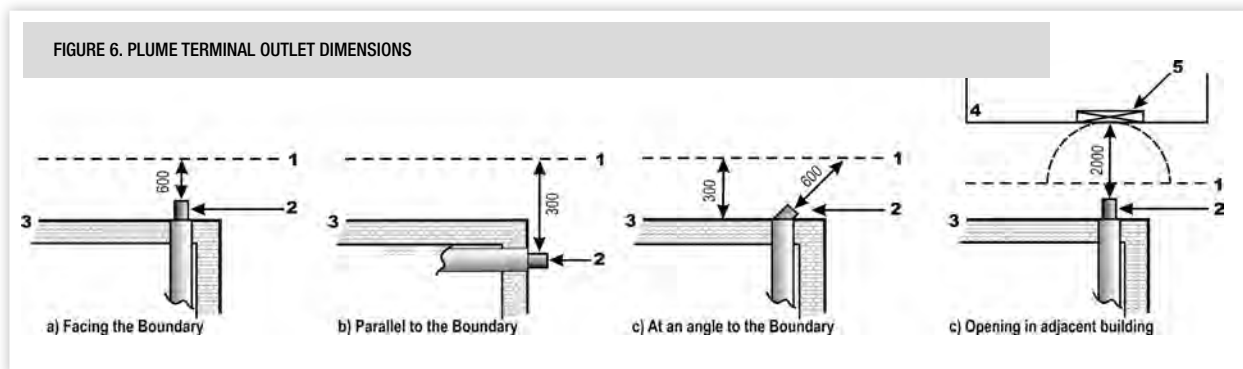
9.7.5 The flue MUST NOT be installed under a car port.

## 9.8 PLUME TERMINAL OUTLETS

9.8.1 A flue duct outlet of an appliance should be at least 600mm from the boundary line when facing it and at least 300mm from the boundary line when running parallel to it. See Figure 6.

**NOTE:** When the flow of products is at an angle to the boundary, the 600mm dimension may be measured in the direction of the flow, as long as the terminal is not less than 300mm from the boundary.

9.8.2 It is recommended the terminals are not sited within 2m of an opening in an adjacent building or within 2m of the boundary facing the terminal if the plume is likely to cause a nuisance to a neighbour, e.g discharging over a walkway or patio.



## 9.9 FLUE REQUIREMENTS & GENERAL INFORMATION

9.9.1 Extended horizontal and vertical concentric flues (60/100mm diameter) with balanced terminals may be installed on the WarmCair C10D warm air heater.

9.9.2 If an extended horizontal flue is being used it must have a continuous fall back towards the appliance of 3° (52mm) per meter. This ensures that condensate runs back into the appliance from the flue system for safe discharge via the condensate waste pipe. Reference should be made to Table 5 for relevant part numbers.

9.9.3 The maximum length of flue permissible is 10 meters including terminal

9.9.4 The minimum vertical flue length is 1.25m from the top of the appliance case to the top of the terminal.

9.9.5 Longer flues may be fitted, however the input of the appliance will be reduced accordingly.

9.9.6 Elbows may be fitted within the flue system with a corresponding reduction in overall flue.

9.9.7 Guidelines for the maximum flue length are as follows.

HORIZONTAL FLUE			VERTICAL FLUE	
UNIT TURRET	90° ELBOW	STRAIGHT 1m FLUE	90° ELBOW	STRAIGHT 1m FLUE
1	-	12	-	12
1	1	8	1	8
1	2	6	2	6
1	3	4	3	4

When using 45° elbows: 2 x 45° elbow = 1 x 90° elbow

TABLE 3

## 9.10 CONVENTIONAL 60/100mm FLUE ACCESSORY PARTS No's

DESCRIPTION	COLOUR	QTY	APPLICATION	PART No.
1 800mm Horizontal Terminal	White	1	Horizontal	1000-0019830
2 Vertical Appliance Adaptor	White	1	Vertical	1000-0018990
3 45° Elbow	White	1	Horizontal & Vertical	1000-0018970
4 90° Elbow	White	1	Horizontal & Vertical	1000-0018980
5 250mm Straight Extension	White	1	Horizontal & Vertical	1000-0018960
6 500mm Straight Extension	White	1	Horizontal & Vertical	1000-0018950
7 1000mm Straight Extension	White	1	Horizontal & Vertical	1000-0018940
8 2000mm Straight Extension	White	1	Horizontal & Vertical	1000-0025570
9 Flat Roof Weather Collar		1	Vertical	1000-0020060
10 Pitched Roof Collar	Black	1	Vertical	1000-0020030
11 Ridge Terminal	Terracotta	1	Horizontal & Vertical	1000-0021030
12 Wall Fixing Bracket 100mm		1	Horizontal & Vertical	1000-0018930
13 1140mm Vertical Terminal	White/Black	1	Vertical	1000-0020740
14 <b>Plume Management Kit</b>	Black	1	Horizontal & Vertical	1000-0020730
15 1000mm Extension Flue 60mm	Black	1	Horizontal & Vertical	1000-0020740
16 90° Elbow 60mm Ø	Black	1	Horizontal & Vertical	1000-0020680
17 45° Elbow 60mm Ø	Black	2	Horizontal & Vertical	1000-0020670
18 Wall Fixing Bracket 60mm		1	Horizontal & Vertical	1000-0020770
19 <b>Flexible Flue Kit 60/100mm 5 &amp; 10m</b>	Black	1	Flexible	FFK5/FFK10
20 Flexible Black Outer Pipe	Black	1	Flexible	1000-0023410
21 Flexible Grey Inner Pipe	Grey	1	Flexible	1000-0023420
22 Outer Rigid to Flex Adapter	Grey	1	Flexible	1000-0023430
23 Inner Rigid to Flex Connector	Grey	1	Flexible	1000-0023440
24 Outer Flex to Rigid Adapter	Grey	1	Flexible	1000-0023450
25 Inner Flex to Rigid Connector	Grey	1	Flexible	1000-0023460
26 Outer Seal Pipe Rings		2	Flexible	1000-0023470
27 Inner Seal Pipe Rings		2	Flexible	1000-0023480
28 Centalising Spacer Ring		1	Flexible	1000-0023490
29 Flue Support Kit		1	Flexible	1000-0023500
30 Draw Cone & Rope		1	Flexible	1000-0023510
31 <b>Chimney Terminal Kit 60/100mm</b>	Black	1	Vertical	CTK-60/100
32 Skyline Terminal & Outer Flue Cowl	Black	1	Vertical	1000-0023990
33 Locking Ring	Grey	1	Vertical	1000-0026610
33 Flashing Ring	Grey	1	Vertical	1000-0026660
34 Chimney Cover Plate		1	Vertical	1000-0026600

TABLE 4. 60/100mm FLUE COMPONENTS

### 9.11 EXTENDED HORIZONTAL FLUE SYSTEM

Extended horizontal flue set up comprises of:

- The required flue lengths up to a length of 10m
- 800mm Horizontal Terminal
- 90° Elbow
- Inside Wall Cover Plate
- Outside Wall Cover Plate
- 100mm Diameter Clamp (1 per flue length)

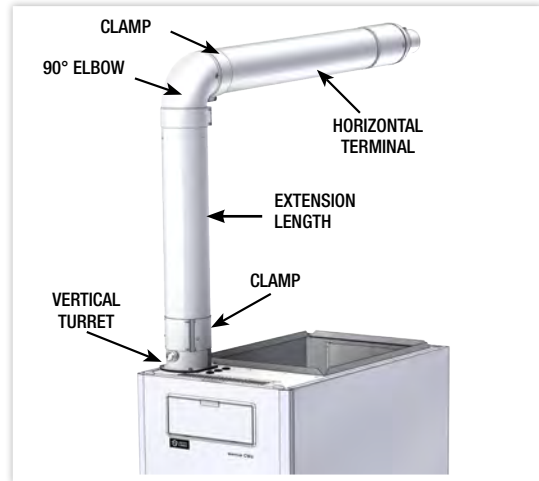


FIGURE 7. EXTENDED HORIZONTAL FLUE

### OPTIONAL ROOF OUTLETS AVAILABLE

#### 9.12 FLAT ROOF OPTION

The Flat Roof Collar.

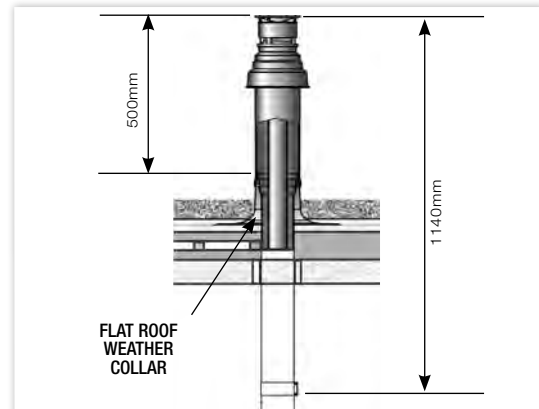


FIGURE 8. OPTIONAL ROOF OUTLET

#### 9.13 PITCHED ROOF OPTION

A Pitched Roof Collar can be fitted on a pitched roof with an angle of between 20° to 50° pitch.

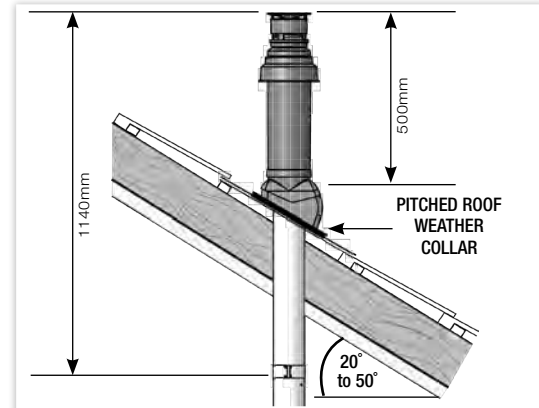
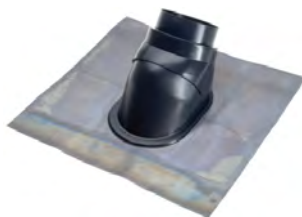


FIGURE 9. OPTIONAL ROOF OUTLETS

#### 9.14 RIDGE TERMINAL OPTION

The Ridge Terminal replaces a single 450mm ridge tile and connects to a vertical flue system.

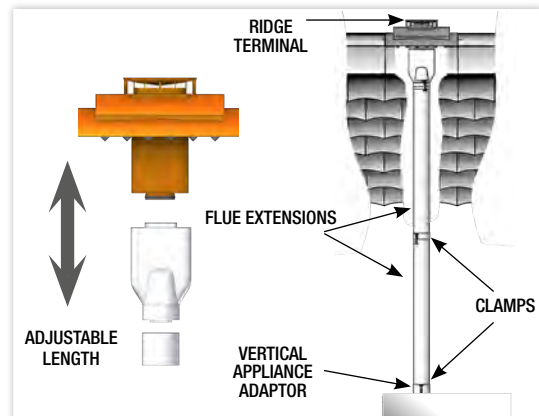


FIGURE 10. OPTIONAL ROOF OUTLETS

## 10. CONDENSATE PUMP & DRAIN TUBE

### 10.1 CONDENSATE PUMP

10.1.1 Supplied with 6mm x 10m condense tube. Condense adapter and 2 x clips.

**SAFETY NOTE:** If the pump fails, the safety float switch will shut off the heater operation.

**10.1.2 DO NOT HANDLE PUMP IN WET CONDITIONS OR WITH WET HANDS**

10.1.3 To reduce the risk of electric shock, ensure the electrical supply is permanently wired to earth.

#### 10.1.4 TECHNICAL DATA

- a) Tank capacity : 0.5L
- b) High level safety cut out
- c) Outlet size 6mm I.D.
- d) Maximum water temperature: 60°
- e) Maximum noise level: 21 dB(A) at 1m

10.1.5 Where the tubing from the pump is connected directly to the soil stack or waste pipe, there must always be either a waste trap after the tubing connections, or a 75mm 'U' trap formed within the tubing.

10.1.6 Where the tubing from the pump is connected to an external soil and vent stack extra care is necessary to ensure that the condense pipe could not be blocked through the condense freezing.

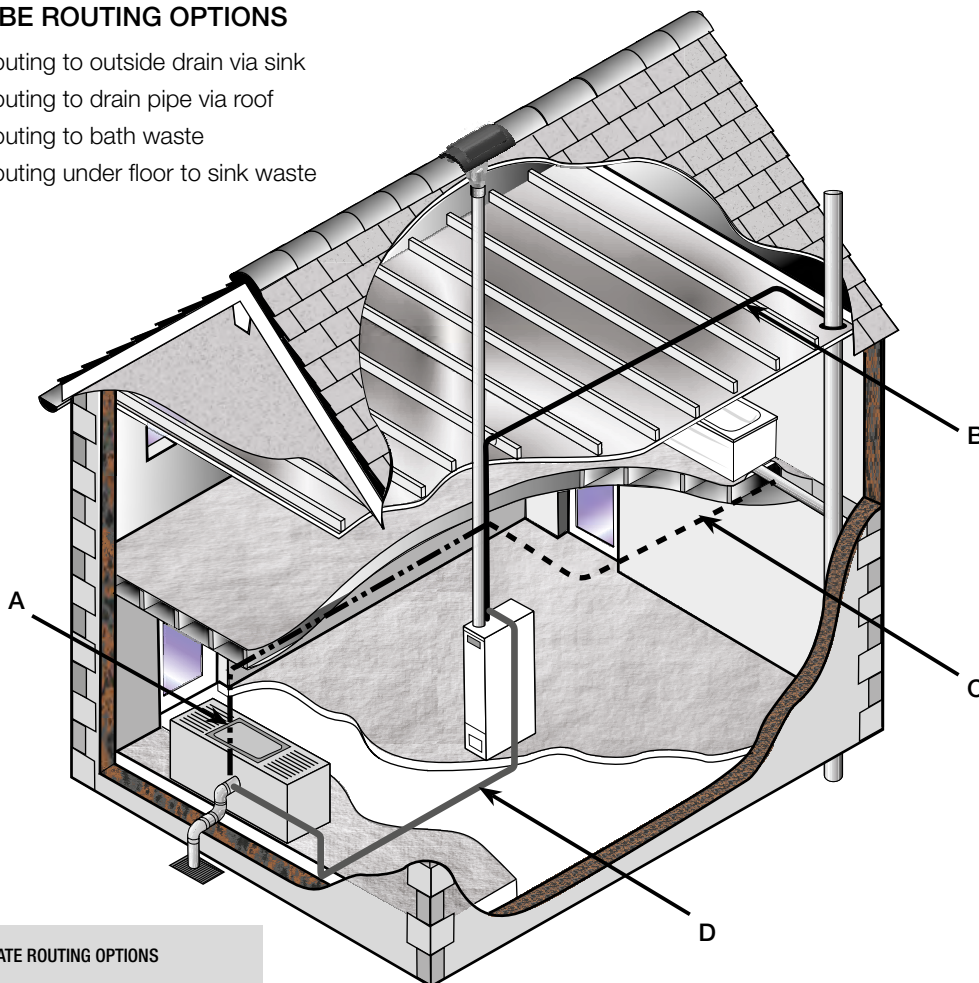
10.1.7 The tank pump uses small bore (6mm) flexible hose which can be routed above or below doors, windows and under kitchen cabinets.



FIGURE 11. CONDENSE PUMP

### 10.2 CONDENSATE TUBE ROUTING OPTIONS

- Option A. Routing to outside drain via sink
- Option B. Routing to drain pipe via roof
- Option C. Routing to bath waste
- Option D. Routing under floor to sink waste



**NOTE:**  
7m MAXIMUM HEAD  
LENGTH OF CONDENSE  
TUBE

FIGURE 12. CONDENSATE ROUTING OPTIONS

## 11. GAS (See BS 5864 and BS 6891)

- 11.1 The local gas supply conditions MUST be adequate for the specified burner pressures as stated in the technical specification (section 5).
- 11.2 An independent gas supply pipe from the meter is to be preferred wherever possible. Where this is not possible, the pipe must be capable of taking the complete input of the heater and all other gas appliances being served by the same pipe. This supply should be suitably sized to conform to British Standards requirements of no more than 1.0 mbar (0.4" wg) pressure drop (See table of discharge in BS 6891).
- 11.3 The ½" union gas cock (supplied) MUST be fitted to the gas inlet of the heater for easy isolation during servicing. The gas pipe should be fitted and installed so as to be durable, substantial and gas tight. To assist in determining where a gas connection may not be tight, a leak detection fluid should be applied around the connection. Under no circumstances should a flame be used to locate a gas leak. Gas entry to the air heater is through either side or the base, to a 15mm compression fitting.

## 12. ELECTRICAL

### WARNING: THIS APPLIANCE MUST BE EARTHED!

#### 12.1 MAINS SUPPLY

The heater is supplied with mains cable (PVC sheathed, heat resisting to 85°C), 3 core: Brown; Blue; Green/Yellow, 6A, 0.75mm<sup>2</sup>), connected to the PCB control panel and exiting through the heater at the left hand top. The cable is suitable for a 230V 50Hz supply and requires connection to the fixed wiring using a double pole switched, fused spur with a contact separation of at least 3mm in ALL poles. The fuse fitted must be rated 5A to BS 1362. Connections must also be in accordance with the current edition of I.E.E Regulations BS 7671.

**NOTE:** If, for any reason, the heater is re-wired, then 3 core cable that meets the above specification MUST be used. Under NO circumstances, should 5 core cable be used for the combined purpose of supplying power to the heater and connecting the Open Therm Controller!

- Fan delay and overheat (limit controls) are not adjustable and are factory set.
- An Open Therm Controller is supplied which acts like a room thermostat.

#### 12.2 OPEN THERM CONTROLLER AND ITS LOCATION

This appliance must be interfaced with the following: Open therm room units (supplied). The open therm controller supplied is a fixed wired option. For wireless and "smart" upgrades, consult [sales@johnsonandstarley.co.uk](mailto:sales@johnsonandstarley.co.uk).

12.2.1 The room-stat should be located where there is free air circulation and positioned approx. 1.5m (5ft) from the floor.

12.2.2 Avoid the following locations:

- In a room where temperature is greatly affected by the sun or any other heat source, e.g. radiant fire, wall light fittings or TV set.
- Near an outside door or windows, or on an outside wall.
- Where it will be affected by warm air ducts, diffusers, waste pipes or the heater itself.
- Where it will be subjected to vibration.

12.2.3 Refer to wiring diagram 1 for the installation of the thermista-stat. See Figure 32.

12.2.4 In line with specific advice given during installer training courses in September, October and November 2019, the fitting of any Non Open Therm-Compatible Controller to any of the WarmCair C range of Warm Air Heaters will invalidate the guarantee immediately.

The fitting of this type of controller can cause severe damage to the heat exchanger and under no circumstances should be used.

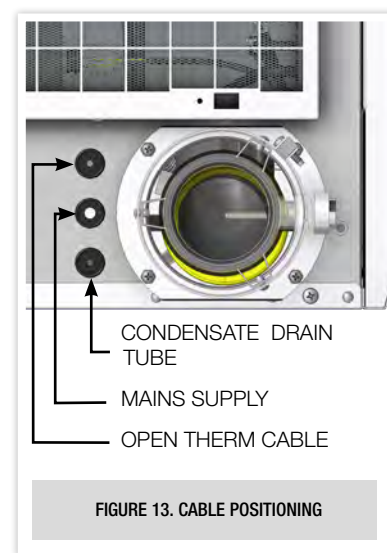


FIGURE 13. CABLE POSITIONING

## 13. FITTING INSTRUCTIONS

**CAUTION: This appliance exceeds the recommended weight for a one man lift as detailed in the Manual Handling Operations, 1992 Regulations.**

It should be noted that this appliance could contain sharp edges and care **MUST** be taken when handling.

### 13.1 FITTING THE APPLIANCE

- 13.1.1 Making sure the plenum is clear from all debris, lift the appliance into place.
- 13.1.2 Using a spirit level it is important the appliance is completely level, this appliance **MUST NOT** lean or tilt in any direction. This will cause problems with the condense draining.
- 13.1.3 Seal the unit to the plenum, using ducting tape (not supplied). Ensure a good seal is made.
- 13.1.3 Installation of the condense tube is a maximum of 10 meters. There should be no trapped kinks in this length of tube.
- 13.1.4 Fix all connections to the appliance ready for commissioning.

## 14. COMMISSIONING

- 14.1 After installation of the appliance, you **MUST** do the following:
  - 14.1.1 Test for gas leakage using proprietary detection fluid and seal any leaks found.
  - 14.1.2 Carry out preliminary electrical system checks.
  - 14.1.3 Ensure that:
    - a. the filter, fan and fan compartments are free from obstructions.
    - b. all registers or grilles are open and conform to design specifications.
    - c. the return, relief and ventilation air installations are adequate.
- 14.2 Switch the air heater electrical Supply ON.
- 14.3. To fill the flue condensate trap, disconnect the sliding flue connector and slowly pour tap water into the elbow until you hear the condensate pump operating. Failure to do this will result in a whistling sound. Check for leaks.

**NOTE:** The appliance must be connected to the mains for the pump to operate.

### 14.4 SYSTEM BALANCING

- 14.4.1 Press button '7' to put the appliance into Summer Air Circulation mode.
- 14.4.2 Balance the system to provide the required volume proportions at the warm air outlets.

FIGURE 14. CONTROL PANEL

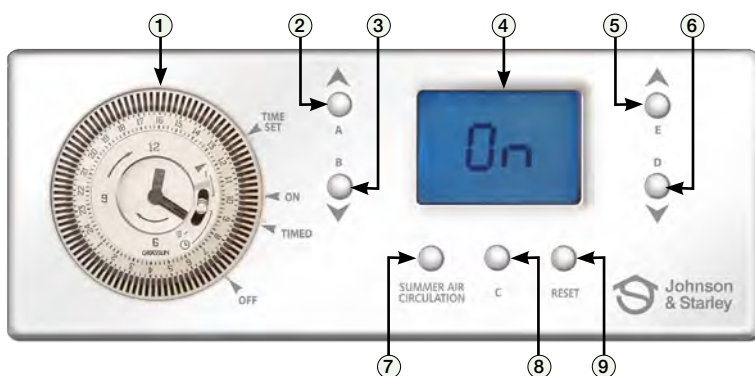
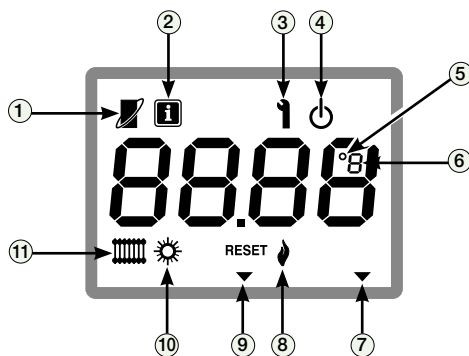


FIGURE 15. LED READ OUT



CONTROL PANEL

1	Time control
2	A +
3	B -
4	LED Display
5	E +
6	D -
7	Summer Air Circulation
8	C
9	Reset
LED READ OUT	
1	Open therm symbol
2	Installer mode indicator
3	Service indicator
4	Stand by
5	Degrees
6	Error - 'e' or celsius - 'c'
7	Reset button indicator
8	Flame indicator
9	Button 'c' indication
10	Summer circulation
11	Central heating



**NOTE:** If the system includes ceiling diffusers, the air through these should be NOT LESS THAN 1.5m/s (300ft/min), except for very small rooms, (i.e. bathrooms etc.). Outlet faces may require partial blanking in order to achieve this.

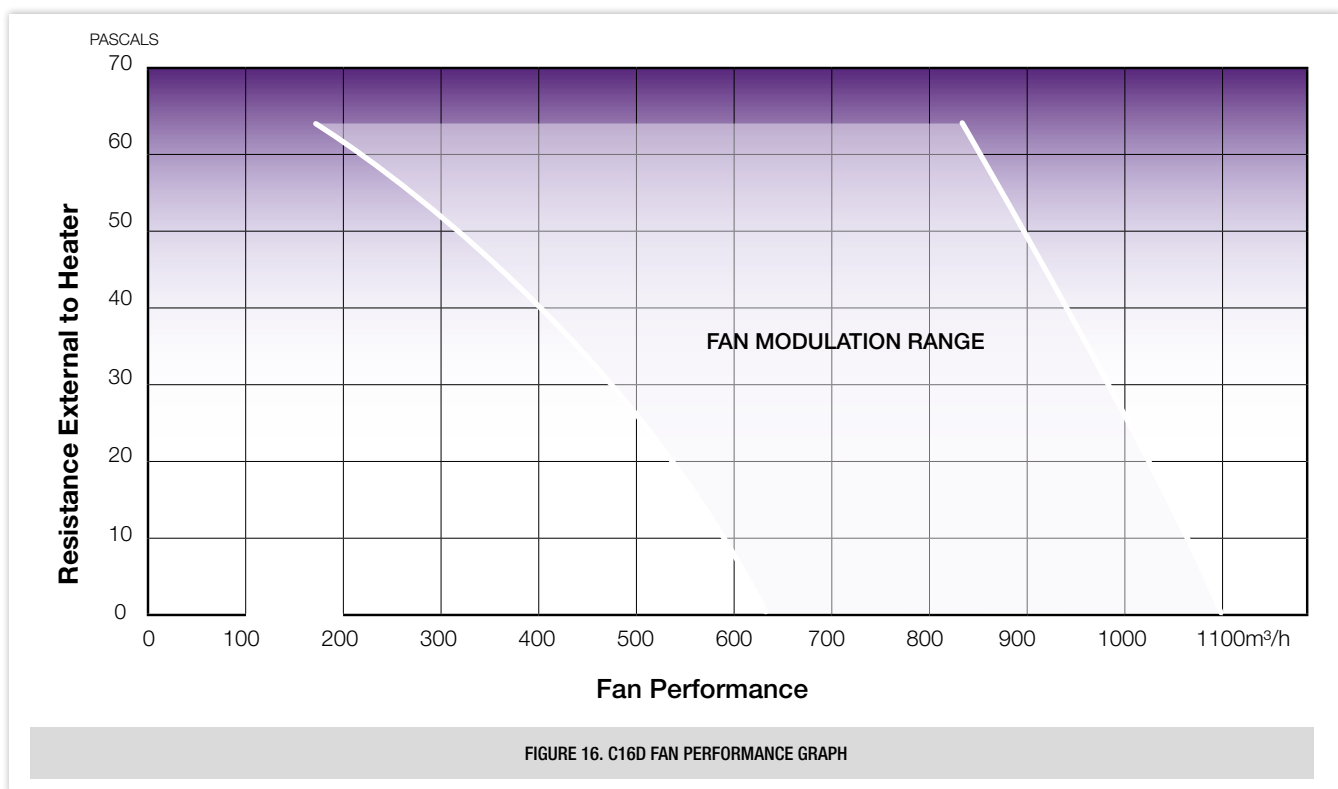
### 14.3 LIGHTING MAIN BURNER

- 14.3.1 Turn on the gas supply to the heater.
- 14.3.2 Set both switches on the time control unit to the "OFF" position.
- 14.2.3 Set the thermista-stat to "MAX".
- 14.3.4 Turn on the mains power supply to the heater
- 14.3.5 Set the "AIR HEATER" switch on the time control to "CONT." and observe the ESYS status indicator.
- 14.3.6 The ignitor will spark for 5 seconds during which time the main burners SHOULD ignite and the igniter will stop.
- 14.3.7 The ESYS on the control panel will run through the ID setting, when finished it shows a flashing "--" sign. This shows its ready.
- 14.3.8 If, after the 5 second period, the main burner has ignited the ESYS will show "ON" and the blue LED "ON" light on the indicator panel will remain steady.
- 14.3.9 If the main burner fails to ignite, you have 4 more attempts at ignition.
- 14.3.10 In the event of a lockout "1" and the ignition and main burners failing to ignite, reference should be made to table 4 in the fault finding section of these instructions in order to establish the fault condition.
- 14.3.11 Allow the air heater to operate for a minimum of 15 minutes to ensure stability.
- 14.3.12 Reset the thermista-stat to the desired comfort level
- 14.3.13 Set the time control to the desired "on and "off" periods.

### 14.4 GAS RATE CHECK

- 14.4.1 There is no burner pressure test with this air heater. It has a 1-1 ratio Valve.
- 14.4.2 Natural Gas (G20) consumption is calculated using gross CV 38.7 MJ/m<sup>3</sup> or 34.9 MJ/m<sup>3</sup> net. Max rate 0.93m<sup>3</sup>/h (32.9ft<sup>3</sup>/h) and min rate 0.466m<sup>3</sup>/h (16.45ft<sup>3</sup>/h)
- 14.5 Complete all relevant sections of the Benchmark Commissioning Checklist located on the inside back pages.

**NOTE**  
 The gas valve is factory preset and must not be adjusted. A replacement valve must only be supplied by Johnson & Starley Ltd.



## 15. HANDING OVER

- 15.1 After commissioning, the installer should hand the appliance over to the occupier of the house by the following procedure:
- 15.2 Hand the User Instructions ZZ1340 to the occupier and explain their responsibilities in respect of current legislation and regulations, both national and local.
- 15.3 Explain and demonstrate how to light and shut down the appliance.
- 15.4 In order to gain the best possible fuel economy in relation to the heating requirements of the household, carefully explain the operation of the appliance and the use/adjustment of all the system controls.
- 15.5 Advise on the precautions required to prevent damage to the appliance; the system and the building in the event of the appliance being shut down in very cold weather.
- 15.6 Explain how, in the event of a fault, the appliance will display a fault code, emphasising that if a fault is indicated they should note the fault code, turn off the appliance and contact a “competent person” which in normal circumstances would be a GAS SAFE registered engineer.
- 15.7 Explain and demonstrate the function/operation of time/temperature controls, emphasising the economic use of the appliance.
- 15.8 A comprehensive service should be carried out ANNUALLY. Stress the importance of regular servicing by a Gas Safe Registered Engineer. In IE servicing work must be carried out by a Registered Gas Installer (RGI).

### NOTE

**This appliance is not intended for use by persons (including children) with reduced physical, sensory or mental capabilities, or lack of experience and knowledge, unless they have been given supervision or instruction concerning use of the appliance by a person responsible for their safety.**

**Children should be supervised to ensure that they do not play with the appliance.**



**REMINDER: At the time of commissioning, complete all relevant sections of the Benchmark Checklist located on the inside back pages of this document prior to handing over the appliance to the occupier.**

## 16. SERVICING & MAINTENANCE

### 16.1 SERVICING SCHEDULE

To ensure that the appliance gives continued operation that is both safe and efficient, it is necessary to carry out regular service checks and whilst the period between servicing will depend on the installation condition and the demands placed upon the appliance, it is recommended that the appliance be serviced annually.

**IMPORTANT:** It is a statutory requirement that ALL work be carried out by a “competent person” which in normal circumstances would be a GAS SAFE registered engineer.

**NOTE:** In order to carry out either servicing or replacement of components the heater front door must be removed.

### 16.2 SERVICING SEQUENCE

16.2.1 Light the heater and carry out a pre-service check, noting any operational faults.

16.2.2 Check the gas consumption.

16.2.3 **Put the appliance in test mode. Refer to paragraph 18.1. Connect a suitable flue gas analyser to the sampling point on the top of the air heater or into the flue terminal if access is possible (optional test). See Figure 17.**

16.2.4 **For correct air heater operation, the CO to CO<sub>2</sub> ratio should be checked at the maximum and minimum in test mode.**

16.2.5 **Check that the gas input is at least 90% of the nominal.**

**WARNING.** Always turn OFF the gas supply at the gas service cock and switch OFF. Disconnect the electricity supply to the appliance before servicing.



FIGURE 17.  
GAS FLUE TEST POINT

### COMPONENT SERVICING CHECKLIST

16.2.6 Clean and check the main burner and electrodes. See paragraph 16.4.

① 16.2.7 Visually check combustion chamber, removing any debris. See section 16.8.

② 16.2.8 Remove the Combustion Air Fan (CAF) and clean. See section 16.8.

16.2.9 Check the condensate pipes and tubes for blockages.

16.2.10 Check that the flue terminal is unobstructed and that the flue system is fully assembled correctly.

③ 16.2.11 Remove the Air Circulation Fan (ACF) and filter, inspect and clean. See paragraph 16.7.

16.2.12 After completing the servicing or exchange of components, always test for gas tightness and carry out functional checks as described above.

16.2.13 When work is complete, check the condition of the sealing foam in the inside of the front door panel. When the door is refitting you must make ensure a good seal is made.

16.2.14 **After servicing, complete the relevant Service Interval Record section of the Benchmark Checklist located on the inside back pages of this document.**

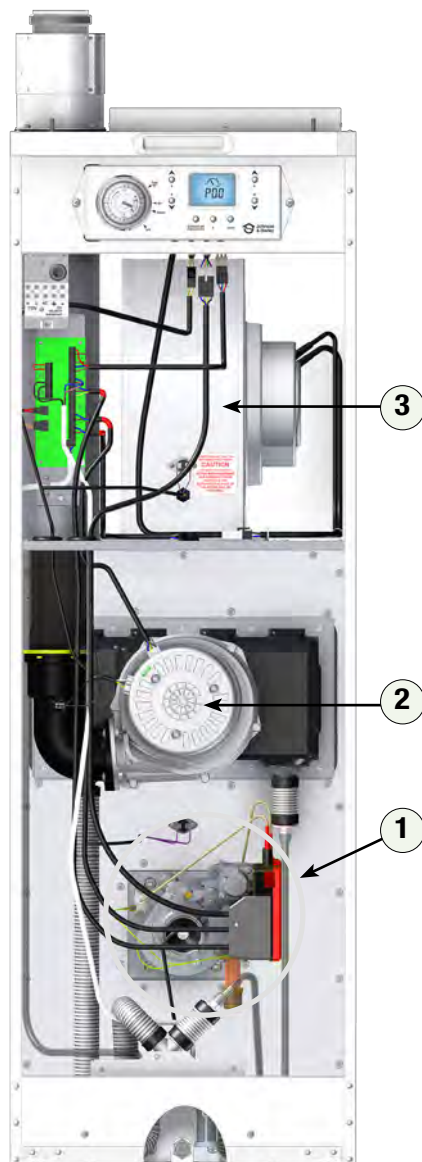


FIGURE 18. SERVICING SEQUENCE

### 16.3 GAINING ACCESS FOR SERVICING

- 16.3.1 Ensure the electrical & gas supply is isolated as needed.
- 16.3.2 Remove the return air filter and pull the bottom front panel off.
- 16.3.3 Remove the front panel by unscrewing the 4 retaining screws at top and bottom.
- 16.3.4 Remove the front cover.

### 16.4 MAIN BURNER ASSEMBLY

- 16.4.1 Refer to section 16.3. See Figure 19.
- 16.4.2 Disconnect the gas pipe at the top of the isolation valve.
- 16.4.3 Disconnect the electrode, igniter and earth leads from the ESYS, then remove the screw and panel on the ESYS and remove. Disconnect the electrical connections.
- 16.4.4 Remove the two screws from the valve/venturi assembly and withdraw.
- 16.4.5 Remove the 4 nuts and washers securing the burner assembly to the heat exchanger and withdraw the assembly, take care not to damage the internal ceramic pad.
- 16.4.6 Inspect the inside of the burner assembly for debris. Clean with a soft brush if necessary.
- 16.4.7 Inspect the gaskets and replace if necessary.
- 16.4.8 Inspect and clean the spark ignition and flame sensing electrode, removing any debris and oxidization. Check the spark gap and position of the spark electrode and the positioning of the flame sensing electrode.
- 16.4.9 Once reassembled re-check electrode and igniter nuts are tight.
- 16.4.10 Refit in reverse order ensuring a good seal is made.

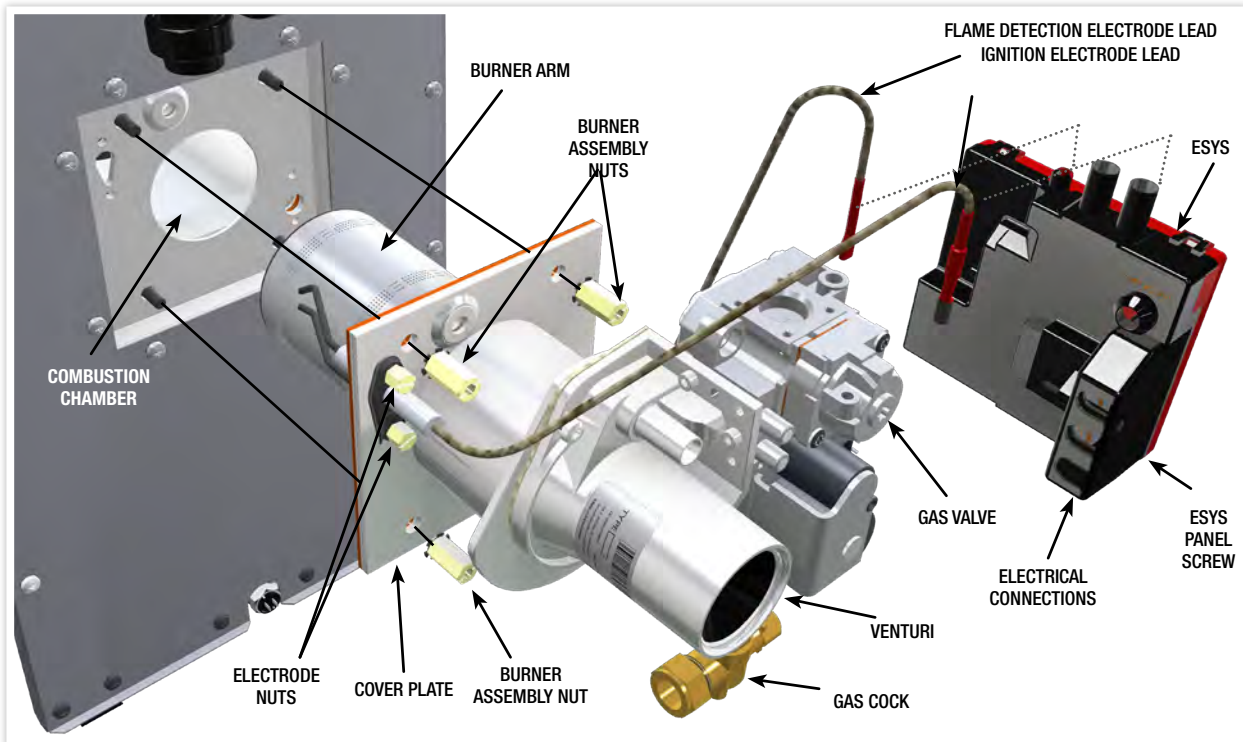


FIGURE 19. MAIN BURNER ASSEMBLY REMOVAL

### 16.5 IGNITION & FLAME DETECTION ELECTRODE

- 16.5.1 Refer to section 16.3. See Figure 19 & 20.
- 16.5.2 Follow 16.4.4 to remove the valve/venturi.
- 16.5.3 Unscrew the two nuts that retain the electrode to the cover plate and remove the assembly.
- 16.5.4 Inspect and clean the electrode, removing any debris and oxidization. If necessary use an abrasive paper or cloth.
- 16.5.5 Inspect the gasket and replace if necessary during re-assembly.
- 16.5.6 Repeat sequence for the flame detection electrodes with the exception of the earth lead.
- 16.5.7 Refit in reverse order and tighten nuts.

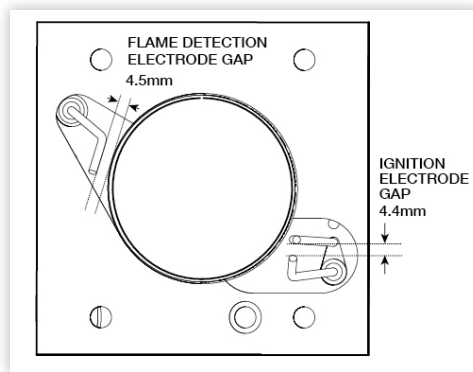


FIGURE 20. ELECTRODE GAPS

**16.6 HEAT EXCHANGER/COMBUSTION CHAMBER**

- 16.6.1 Refer to section 16.3 and 16.4. See Figure 29.
- 16.6.2 Once the burner assembly has been removed inspect the inside of the combustion chamber for debris. If the inner insulation is damaged, do NOT try to clean. Replace the heat exchanger.

**16.7 COMBUSTION AIR FAN (CAF)**

- 16.7.1 Isolate the gas supply and refer to section 16.3.
- 16.7.2 To release the sliding flue connection, slide upwards.
- 16.7.3 Unplug the multi pin plug connections from the fan and remove the connector from the flue sensor. See Figure 21.
- 16.7.4 Carefully remove the condensate pipe from the bottom of the flue elbow. This will contain water.
- 16.7.5 Rotate the CAF and elbow assembly 45°clockwise and withdraw complete assembly.
- 16.7.6 Carefully inspect both the impellor.

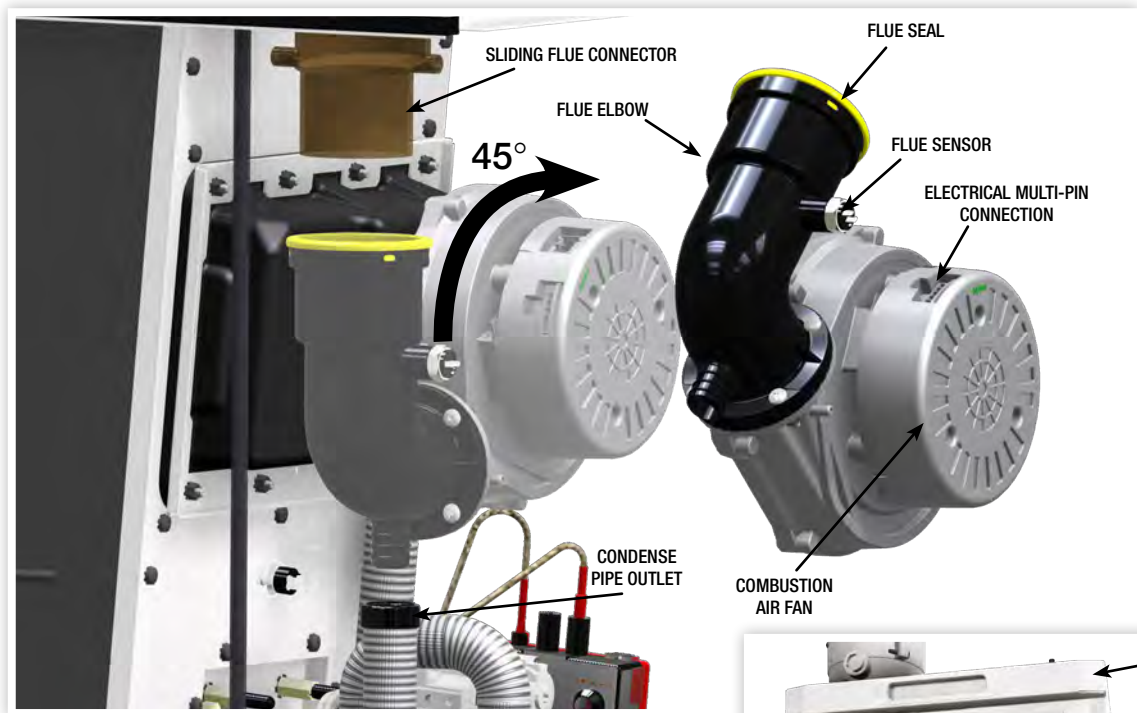
**NOTE:** Pre 2016 models inspect the mesh in the collection box for debris. If the mesh is full replace with new.

- 16.7.8 Refit in reverse order.

**16.8 AIR CIRCULATING FAN (ACF)**

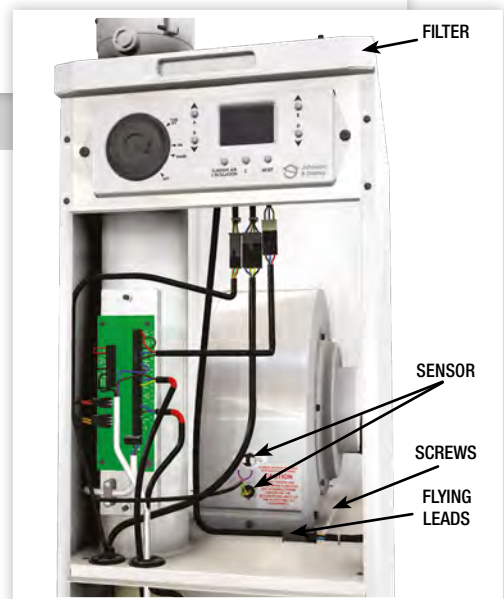


**FIGURE 21.**  
COMBUSTION AIR PASSAGE REMOVAL



**FIGURE 22.** COMBUSTION AIR FAN

- 16.8.1 Refer to section 16.3.
- 16.8.2 Unplug sensor wires and tubes from the air pressure switch, main power connector and low voltage flying leads.
- 16.8.3 Release the fan assembly securing screws, slide the fan assembly forwards on the runners and drop down, remove from the heater cabinet. Avoid damaging the fan blades. See Figure 23.
- 16.8.4 Remove all dust from both the impellor and motor, taking care not to disturb the balance of the fan.
- 16.8.5 Refit in reverse order.



**FIGURE 23.**  
FILTER & AIR CIRCULATION FAN

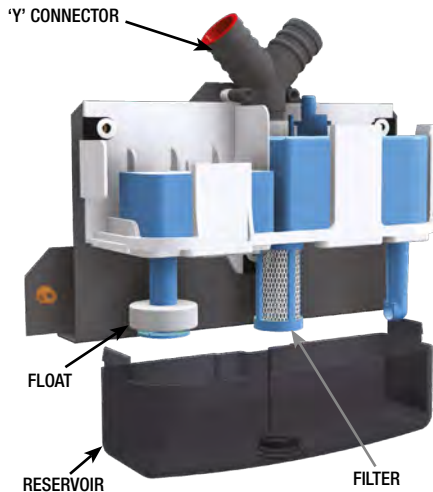


FIGURE 24. CONDENSATE PUMP

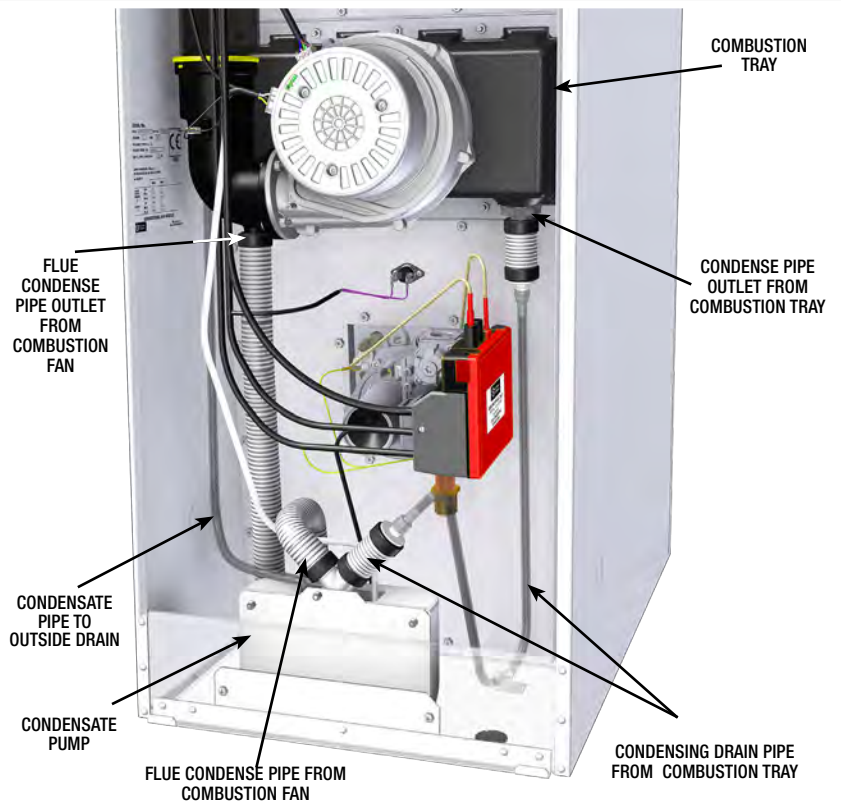


FIGURE 25. CONDENSATE PIPEWORK LAYOUT

## 16.9 CONDENSATE DRAIN PIPES

- 16.9.1 Refer to section 16.3. See Figure 25.
- 16.9.2 Be careful when disconnecting the drain pipes and tubes, they will contain water. Drain as necessary.
- 16.9.3 The flexible condensate pipes are push fit. Disconnect the pipes from the condensate pump and combustion tray.
- 16.9.4 Make sure there are no blockages in the condensate pipes and tubes.
- 16.9.5 Reconnect the condensate drain pipe to the condensate pump.

**IMPORTANT:** The condensing tube from the combustion tray **MUST** be routed so the tube forms a 'S' shape, forming a 'U' trap.

**IMPORTANT:** Ensure the condensate tube is protected and can not freeze in an unheated area.

- 16.9.6 Disconnect the flue elbow outlet and pour water into the condensate drain pipe and check for leaks. Re-connected the pipe to the flue outlet.
- 16.9.7 Refit in reverse order.

## 16.10 CONDENSATE PUMP

- 16.10.1 Refer to section 16.3. See Figure 25.
  - 16.10.2 Disconnect the electrical connections on the electrical panel for Condensate Pump and float switch.
  - 16.10.3 Disconnect the condensate pipes from the 'Y' Connection.
- PLEASE NOTE** The condensate pump, pipes and tubes will contain water.
- 16.10.4 Remove the screw holding the 'Y' connection. Unclip the casing and remove the 2 screws in the pump. Remove the pump.
  - 16.10.5 Check the tank and filter for debris. Make sure there are no blockages in the condensate pipes and tubes.
  - 16.10.6 Clean the tank, filter and floats with warm soapy water. Rinse completely when finished.
  - 16.10.7 Check the inlet and outlet pipe ensuring there are no restrictions to the flow.
  - 16.10.8 Refit the filter and the float making sure it is sitting in the correct position. Refit pump.
  - 16.10.9 Reconnect the condensate drain pipe to the condensate pump, leaving the flue outlet disconnected, pour water into the flue pipe outlet to fill the condensate drain pipe and check for leaks. Re-connected the pipe to the flue outlet.

**IMPORTANT:** The condensing tube from the combustion tray **MUST** be routed to tube form an 'S' shape, making a 'U' trap. Fit the tube behind the Condensate Trap to hold it in place.

- 16.10.10 Continue to re-fit in reverse order.

## 17. REPLACEMENT PARTS

- 17.1 **IMPORTANT:** Before commencing with any part replacement the appliance should be isolated from the electrical supply and the gas service cock on the appliance closed.
- 17.1.1 All parts removed should be replaced and refitted in reverse order, ensuring correct seals are made and wires are connected correctly.
- 17.1.2 Remove any debris from within the appliance.
- 17.1.3 When gas-carrying components are replaced the appliance must be tested for gas tightness.

### 17.2 CONTROL PANEL

- 17.2.1 Refer to section 16.3.
- 17.2.2 Because of the complexity and delicate nature of the control panel assembly, it is supplied as a complete kit in a plastic housing.
- 17.2.3 Remove the control panel by unscrewing the 2 screws that hold the module in place, withdraw and unplug the flying leads at the rear and remove the assembly.
- 17.2.4 Fit new and re-fit in reverse order.

### 17.3 AIR CIRCULATION FAN ASSEMBLY (ACF)

- 17.3.1 Refer to section 16.3.
- 17.3.2 Unplug sensor wires. Main power connector and low voltage flying leads.
- 17.3.3 Release the fan assembly securing screw and withdraw the fan assembly from the heater cabinet. See Figure 26.
- 17.3.4 Fit the new fan assembly and re-fit in reverse order.



FIGURE 26.  
AIR CIRCULATION FAN ASSEMBLY

### 17.4 FAN FAILURE TEMPERATURE SENSOR

- 17.4.1 Refer to section 16.3.
- 17.4.2 Remove the Air Circulation Fan. Refer to 16.7.
- 17.4.3 Unplug the 2 wires from the temperature sensor and remove the 2 retaining screws. See Figure 27.
- 17.4.4 Fit new and re-fit in reverse order.

### 17.5 RETURN AIR TEMPERATURE SENSOR

- 17.5.1 Refer to section 16.3.
- 17.5.2 Remove the air circulation fan assembly as described in section 16.7.
- 17.5.3 Unscrew securing nut and remove sensor.
- 17.5.4 Fit new and re-fit in reverse order.

### 17.6 FLUE TEMPERATURE SENSOR

- 17.6.1 Refer to section 16.3.
- 17.6.2 Carefully remove the 2 spade connectors from the sensor and unscrew the sensor from the plastic flue elbow. See Figure 27.
- 17.6.3 Fit new and re-fit in reverse order.

### 17.7 HIGH LIMIT TEMPERATURE SENSOR

- 17.7.1 Refer to section 16.3.
- 17.7.2 Unplug the 2 wires from the temperature sensor and remove the 2 retaining screws. See Figure 27.
- 17.7.3 Fit new and re-fit in reverse order.

### 17.8 DUCT TEMPERATURE SENSOR

- 17.8.1 Refer to section 16.3.
- 17.8.2 Unscrew securing nut and remove sensor.
- 17.8.3 Fit new and re-fit in reverse order.

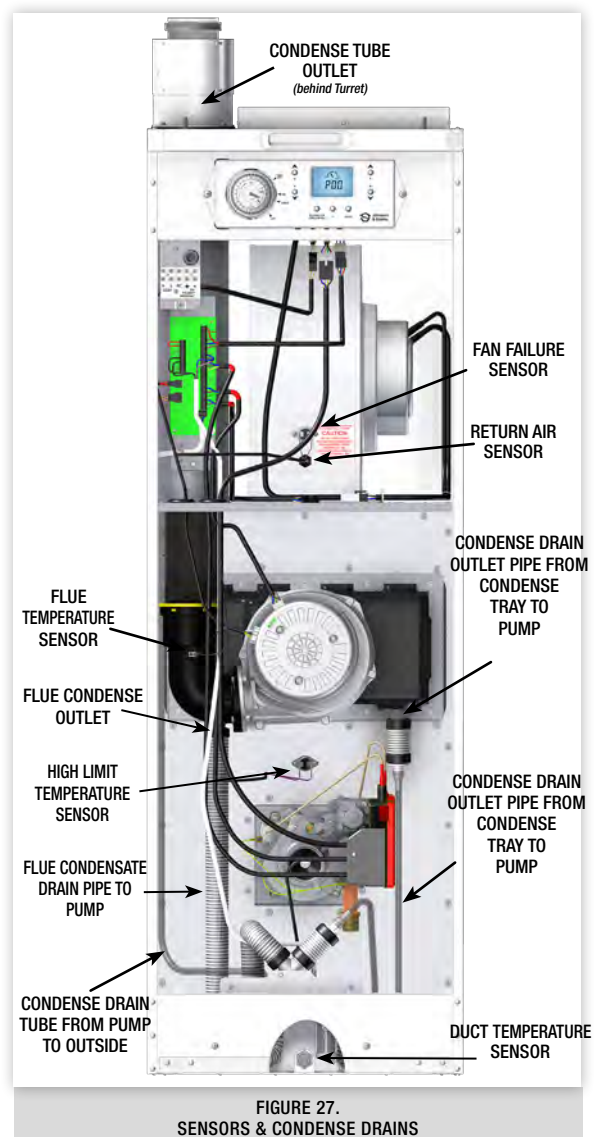


FIGURE 27.  
SENSORS & CONDENSE DRAINS

## 17.8 CONDENSATE PUMP

- 17.8.1 Refer to section 16.3. See Figure 24 & 28.
- 17.8.2 Disconnect the electrical connections on the electrical panel for the Condensate Pump and float switch.
- 17.8.3 Disconnect the condensate pipes from the 'Y' connection and from the flue outlet.

**PLEASE NOTE** The condensate pump, pipes and tubes will contain water.

- 17.8.4 Remove the two screws holding the bracket to the front of the cabinet.
- 17.8.5 Remove the screw holding the 'Y' connection and remove.
- 17.8.6 Unclip the casing and remove the 2 screws holding the pump to the bracket. Remove the pump and replace with new.
- 17.8.7 Check the inlet and outlet pipe ensuring there are no restrictions to the flow.
- 17.8.8 Reconnect the condensate drain pipe to the condensate pump, leaving the flue outlet disconnected, pour water into the flue pipe outlet to fill the condensate drain pipe and check for leaks. Re-connected the pipe to the flue outlet.

**IMPORTANT:** The condensing tube from the combustion tray **MUST** be routed so the tube forms a 'S' shape, making a 'U' trap. Fit the tube behind the Condensate Trap to hold it in place.

- 17.8.9 Continue to re-fit in reverse order.

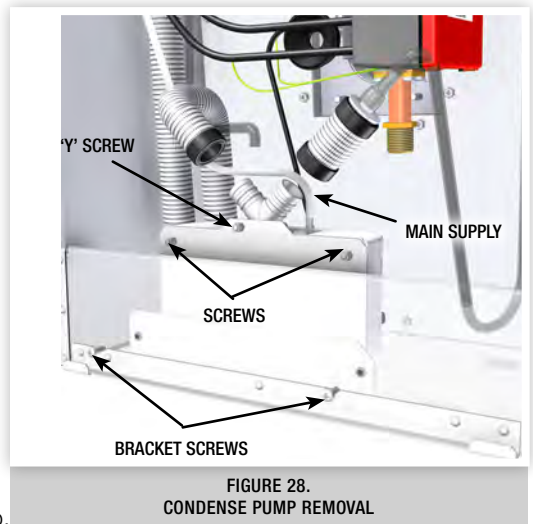


FIGURE 28.  
CONDENSATE PUMP REMOVAL

## 17.9 MAIN IGNITION/CONTROL PCB (ESYS Red Housing on Gas Valve)

- 17.9.1 Refer to section 16.3 and See Figure 28.
- 17.9.2 Unplug the connections from the top of the control and remove the ignition spark detection wires.
- 17.9.3 Unscrew the single retaining screw. Remove cover & unplug the multi-pin connections from the control. Slide the housing off the gas valve electrical connections.
- 17.9.4 Replace with the new ignition control PCB and re-fit in reverse order.

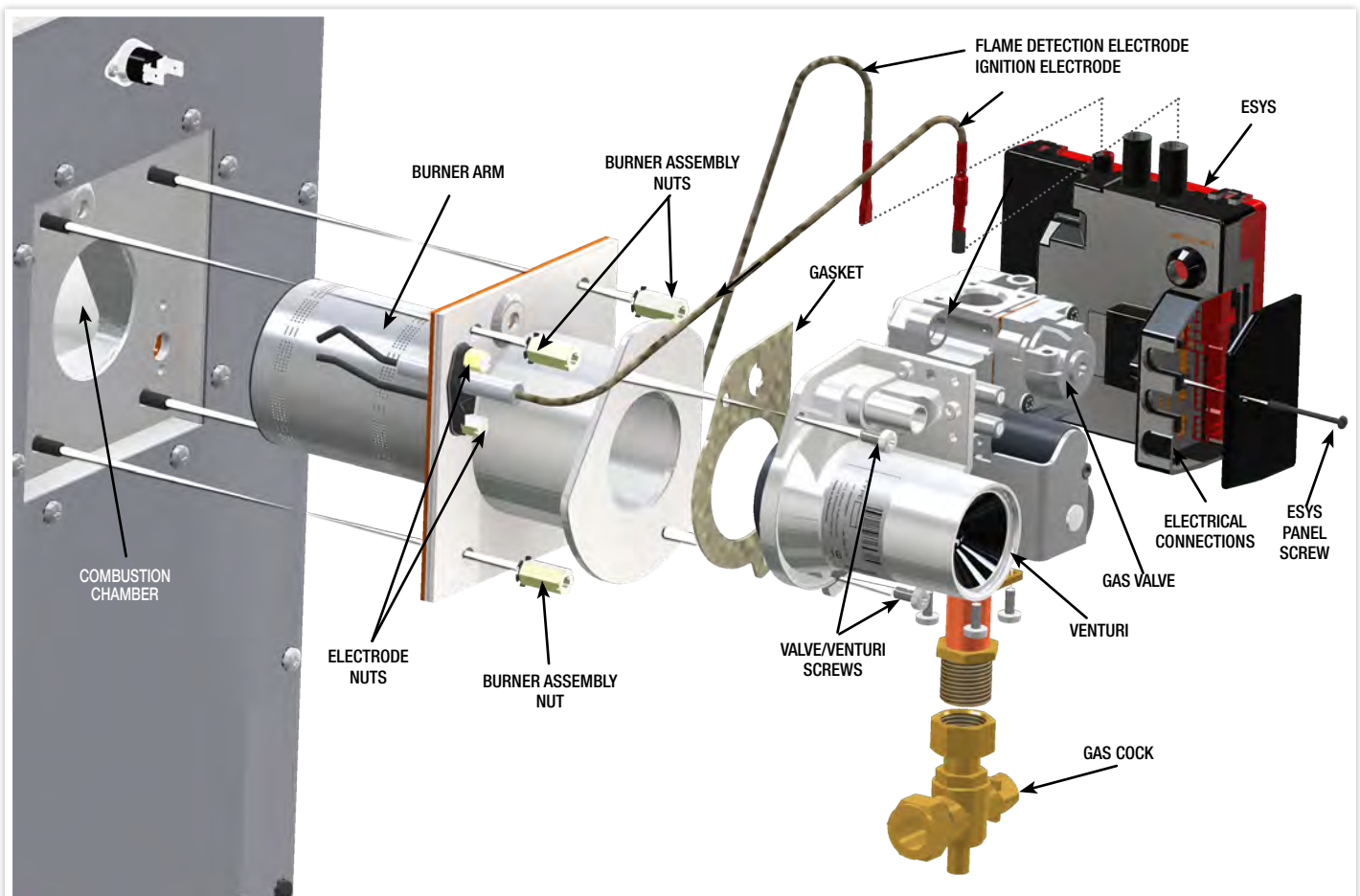


FIGURE 29. MAIN BURNER ASSEMBLY



## 17.10 GAS VALVE & VENTURI ASSEMBLY

**NOTE: The gas valve is factory preset and must not be adjusted. A replacement valve can only be supplied by Johnson & Starley Ltd.**

- 17.10.1 Remove the 2 fixing screws securing the venturi (and gas valve to the burner and remove the assembly from the burner carefully removing the gasket.
- 17.10.2 Replace with the new component and re-fit in reverse order, ensuring all the seals are in good condition and correctly positioned.
- 17.10.3 Check the gas rate and combustion as described in paragraph 14.4.

## 17.11 BURNER ASSEMBLY

- 17.11.1 Refer to section 16.3. See Figure 29.
- 17.11.2 Unscrew the gas joint at the top of the gas cock.
- 17.11.3 Remove the ESYS (red ignition box) & gas valve/venturi assembly. Refer to 17.9 & 17.10 and Figure 21.
- 17.11.4 Remove the 4 nuts and washers securing the burner assembly.
- 17.11.5 Carefully withdraw the assembly from the heat exchanger.
- 17.11.6 Remove the spark detection electrodes, allowing the burner sealing plates to be separated.
- 17.11.7 Fit new and re-fit in reverse order. Make sure all gaskets are replaced with new ones, ensure the rotation position of the burner is correct (indicated by a notch) and the viewing window is in correct position
- 17.11.8 Re-fit in reverse order.

## 17.12 IGNITION ELECTRODES

- 17.12.1 Refer to section 16.3. See Figure 29.
- 17.12.2 Unplug the lead from the ESYS (red ignition box) and earth wire from the back of the electrode. Refer to 17.9 and Figure 19.
- 17.12.3 Remove the 2 remaining nuts and withdraw the electrode.
- 17.12.4 Replace with a new unit, ensuring the gasket is replaced with a new one, or if the existing gasket if reused is in good condition.
- 17.12.5 Re-fit in reverse order.

## 17.13 FLAME DETECTION ELECTRODES

- 17.13.1 Refer to section 16.3. See Figure 29.
- 17.13.2 Unplug the lead from the ignition control. See Figure 19.
- 17.13.3 Remove the two retaining nuts and withdraw the electrode.
- 17.13.4 Replace with new unit, ensuring the gasket is replaced with a new one.
- 17.13.5 Re-fit in reverse order.

**IMPORTANT:** When either the ignition or flame detection electrodes have been serviced or replaced you **MUST** set the clearances as shown in Figure 16.

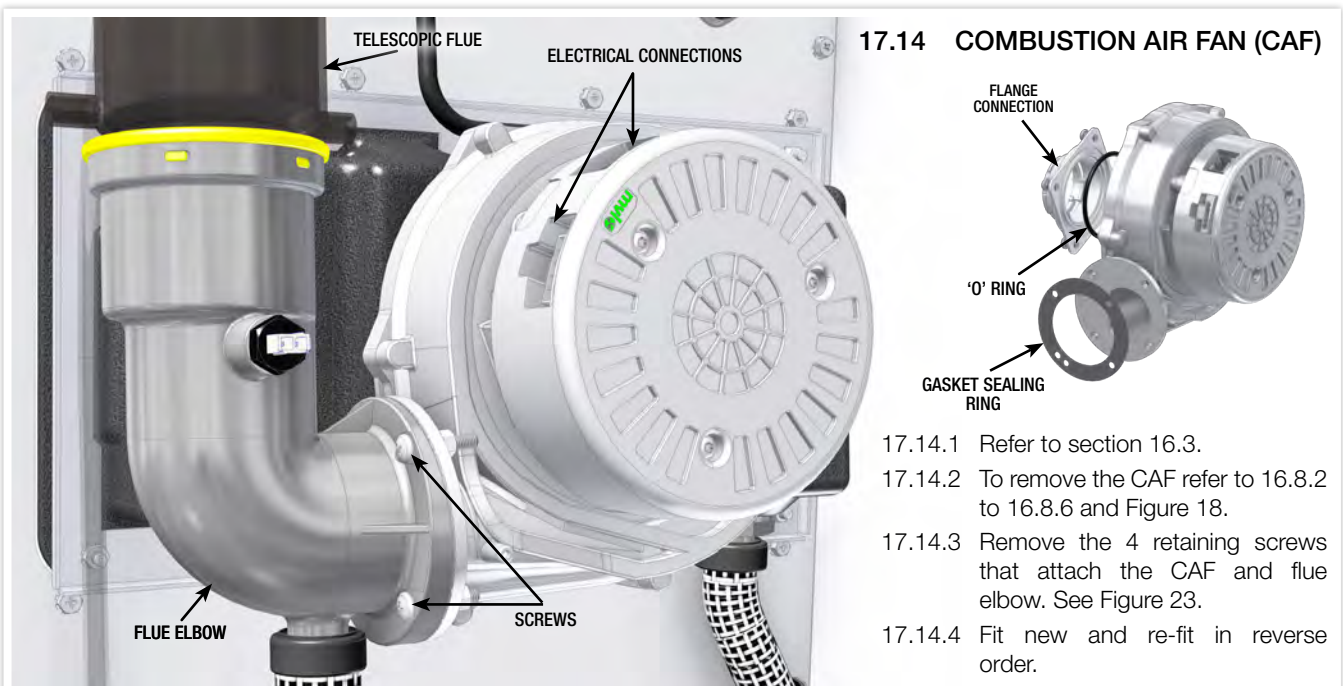
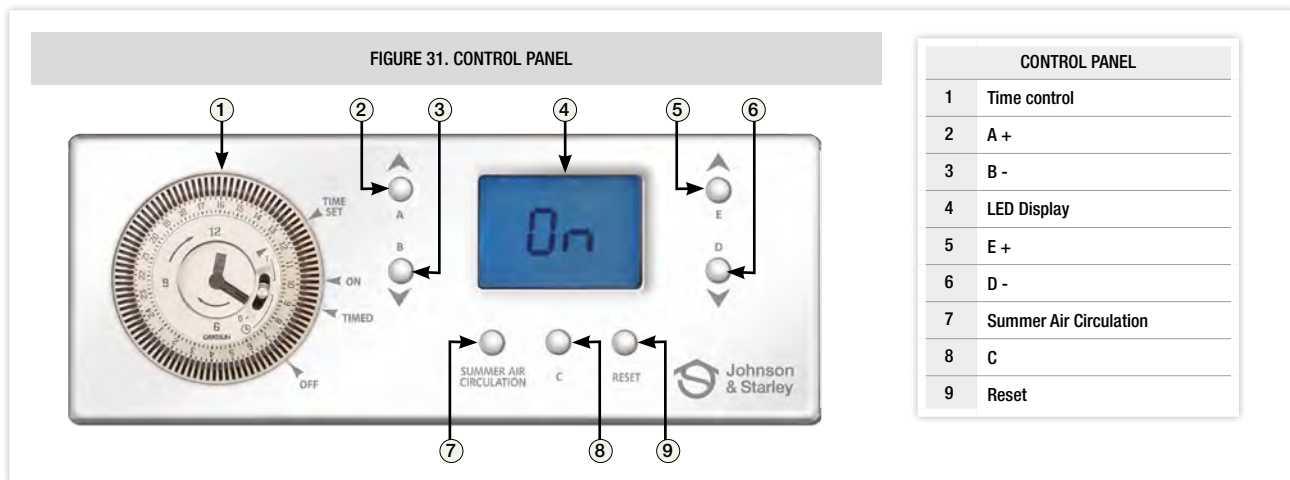


FIGURE 30. COMBUSTION AIR FAN ASSEMBLY

## 18. CONTROL PANEL MODES



### 18.1 TEST MODE

- 18.1.1 To put the appliance in test mode, press Summer Air Circulation (SAC) and C buttons together for more than 3 seconds, until the display changes. (Possible 5 second time delay.) t100 is displayed along with the flame symbol.
- 18.1.2 Whilst in test mode, the appliance overrides all temperature setting and defaults to maximum rate. Pressing the D and E buttons allows you to scroll between maximum and minimum rates, whilst maintaining all protection and error conditions.
- 18.1.3 Press RESET to take the appliance out of test mode. If no changes are made, the appliance will stay in test mode for 30 minutes.

### 18.2 AIR CIRCULATION FAN TEST MODE

- 18.2.1 This mode can be used to adjust the maximum and minimum fan speed output value allowed to drive the ACF fan. (minimum value of 50 to 100 being maximum)
- 18.2.2 Put into fan test mode by pressing 'C' and 'RESET' for 3 seconds. The ACF fan will run with the fan speed value showing on the LCD display, the Value from the ESYS is bypassed.
- 18.2.3 On the display, letter F and the fan speed value is will display, this value can be changed by pressing the A and B buttons accordingly. Once the required value is reached the values can be saved as:
- minimum by pressing button D
  - maximum by pressing button E
- 18.2.4 The display will flash for 2 seconds to confirm it has been saved to the ESYS.
- 18.2.5 Timeout mode is set for 30 minutes, this can be terminated by pressing RESET.
- 18.2.6 The backlight stays on when the test mode is active.

### 18.3 ERROR HISTORY MODE

- 18.3.1 The control panel can store the last 8 error codes. To access these codes press the RESET button for more than 1 second, this will then flash 'H1' on the LCD display.
- 18.3.2 Error 1 being the most recent, along with the error code after the dot. To scroll through the error history press the 'C' button.
- 18.3.3 The unit will stay in error history mode for 30 seconds.
- 18.3.4 To take the unit out of the error history mode press RESET.
- 18.3.5 In order to limit the warm air temperature the heater will shut off the burner and Lt will be displayed in the centre of the display. This will be stored as error 57.
- 18.3.6 Check the filter is clean and the warm air outlets are open.

## 19. FAULT CODE TABLE

### 19.1 CAUTION

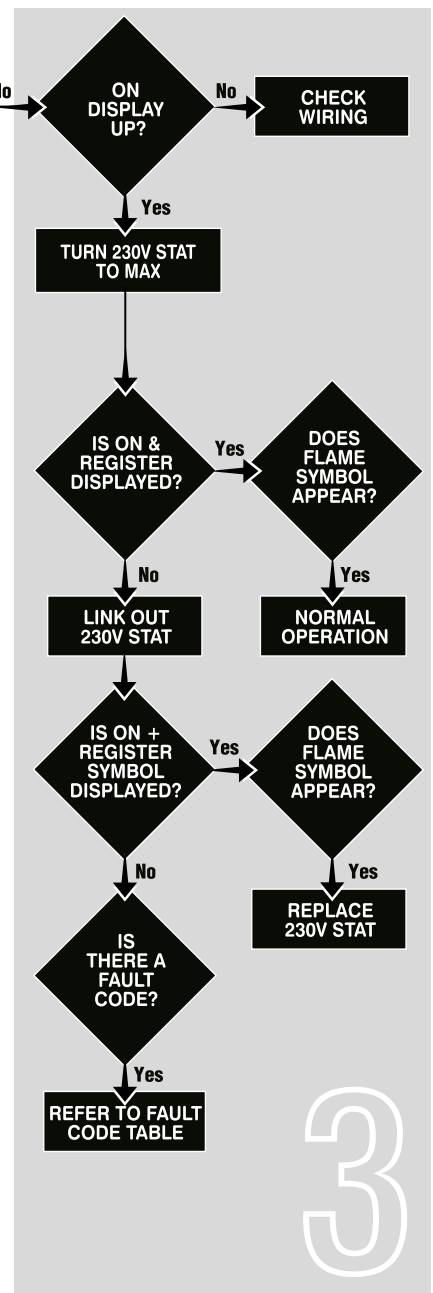
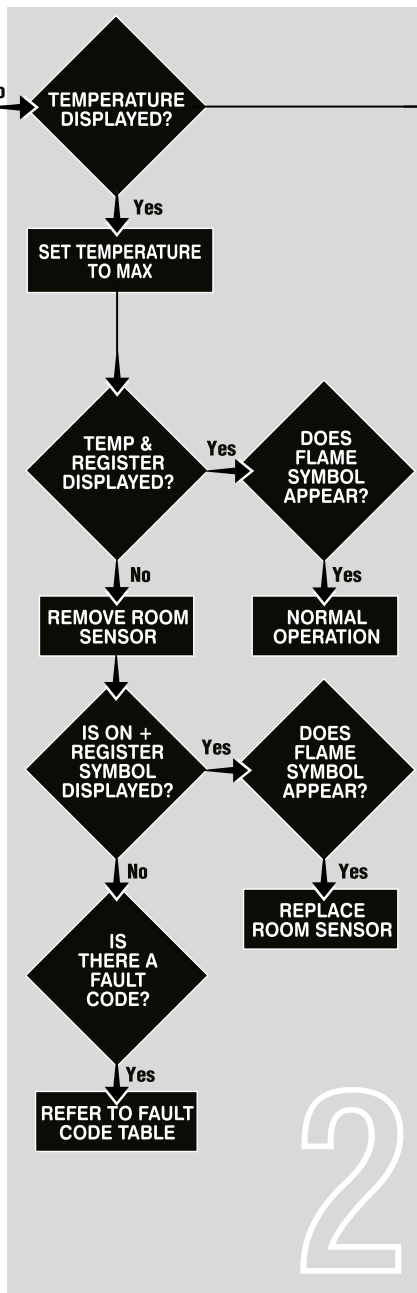
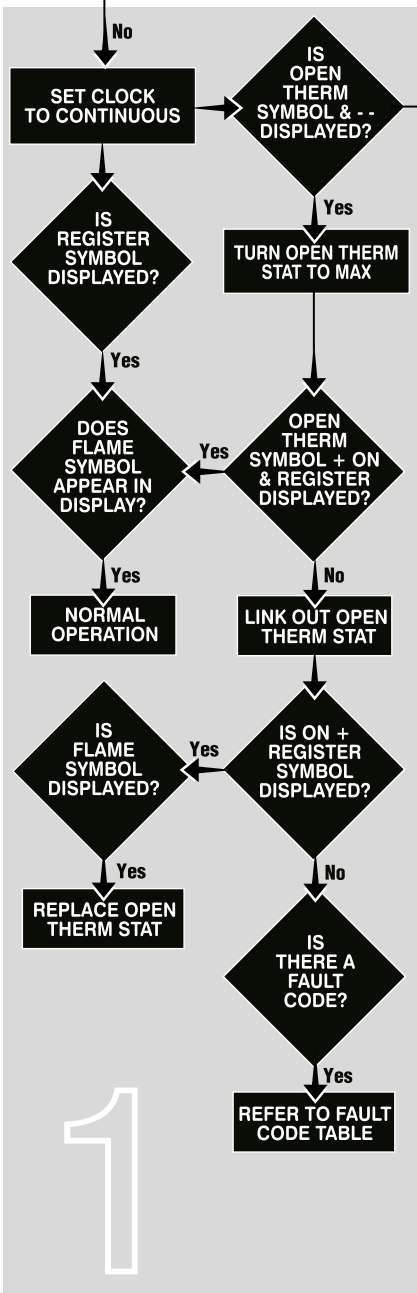
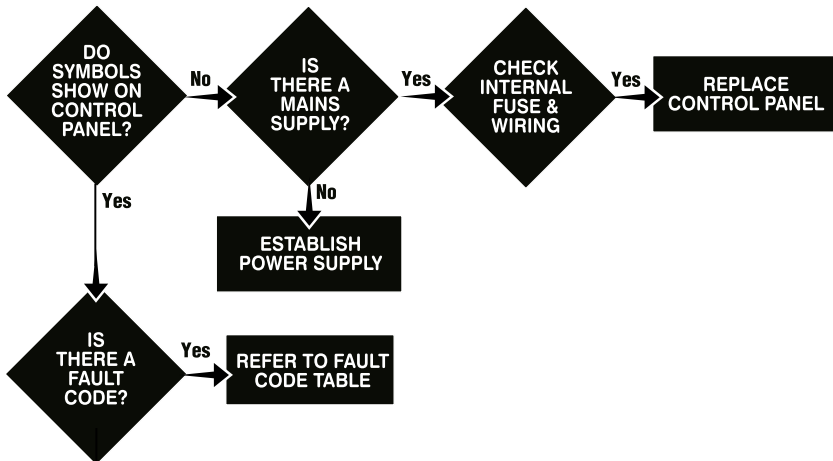
Before commencing any mechanical servicing the appliance should be isolated from the electrical supply and the gas service cock on the appliance closed. All parts that are removed during a service operation should be replaced in reverse order, ensuring correct seals are made and wires are connected correctly. During the service remove any debris from within the appliance. When gas-carrying components are serviced the appliance must be tested for gas tightness after re-assembly. On completion of a service carry out a full functional test of all appliance components and ensure system controls are operating correctly.

TABLE 4		ERROR CODES	
CODE	SYMPTOM	POSSIBLE CAUSE	ACTION
N/A	Heater will not run	No call for heat to heater control board	Check all external controls (if fitted)
			Check setting on time clock
			Check setting of heater controls
1	Flame lockout after several attempts	Flame not detected	Check gas supply and gas cock
			If burner lights, check flame sensor and wiring to control board
			Check operation of gas valve
2	False flame lockout	False flame detected	Check wiring on ESYS
3	Condense pump failure	Power to the pump	Check for any blockages, restrictions or frozen pipes
4	Air pressure switch open	Circulation air fan not running	Check for any dust restrictions or blocked filter
5	No tacho from fan	Fan not running or wiring fault	Check that fan runs
			Check wiring between ESYS and fan
7	Flue gas protection	High flue gas temperature	Check airflow and fan operation
8	Flame circuit error	Flame sensing lead shorted to earth	Check flame detection lead between sensing probe and ignition control board
9	Valve driver circuit error	Gas valve not detected	Check that ESYS is corrected fitted on gas valve
			Replace ignition control board or gas valve
13	Remote reset lockout	Exceeded 5 remote resets per hour	Reset it by power off/on
21	ADC error		Change ESYS
25	CRC error	Different software versions	Change ESYS
26	Flame lost signal lost 5 times in 4 minutes	Flame sensing error. Failing gas pressures. Fan fault. Flue blockage.	Check flame detection lead between sensor and ignition control board
			Check the gas supply, does pressure fall when burner fires?
			Check that flue system is not blocked

## BLOCKING CODES

CODE	SYMPTOM	POSSIBLE CAUSE	ACTION
30	Duct air temperature sensor short circuit	Temperature sensor shorted to earth or failed	Check wiring and connections for shorting to earth
			Check sensor resistance
31	Duct air temperature sensor open circuit	Temperature sensor not connected or failed	Check wiring connections
			Check sensor continuity
34	Low mains supply voltage	Electrical supply fault to property	Check incoming mains supply
		Faulty wiring to appliance	Check wiring to appliance
43	Return air temperature short circuit	Temperature sensor shorted to	Check wiring connections not shorting to earth
			Check sensor resistance
44	Return air temperature sensor open circuit	Temperature sensor not connected or failed	Check wiring connections
			Check sensor continuity
45	Flue gas temperature sensor short circuit	Short circuit in wiring between sensor and control board	Check wiring to sensor
			Check electrical resistance of the sensor
46	Flue gas temperature sensor open circuit	Temperature sensor not connected or failed	Check wiring connections
			Check sensor continuity
57	Restricted airflow	Blocked filter and return air filter/Duct	Check blockage from filter and return air filter/ducts
99	Communication MMI-ESYS lost	Connection between MMI & ESYS incorrectly made	Check wiring and connections

## 20. FAULT FINDING FLOW CHART



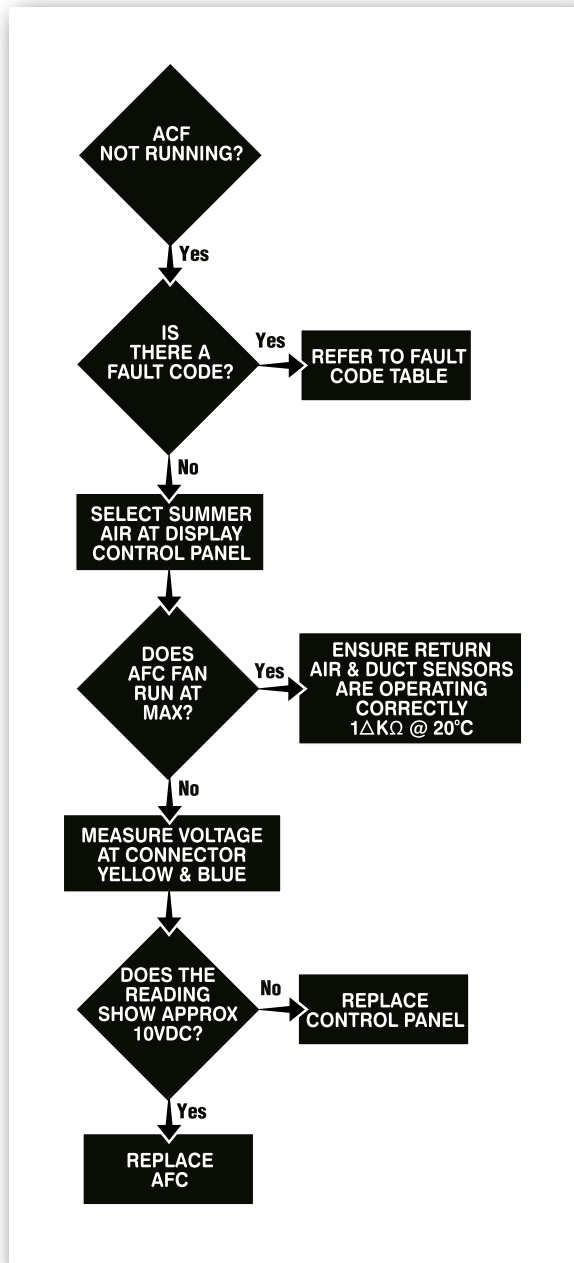
## 21. DEFECT DIAGNOSIS FOR THE CIRCULATION AIR FAN

### 21.1 CIRCULATION AIR FAN

21.1.1 Ensure Air Circulation Fan is running at maximum.

21.1.2 A voltage should be measured and blue (-) and yellow (+). Voltage approx. 10 VDC.

21.1.3 If voltage is present and fan is not running at maximum. Replace ACF.



## 22. FUNCTIONAL WIRING DIAGRAMS

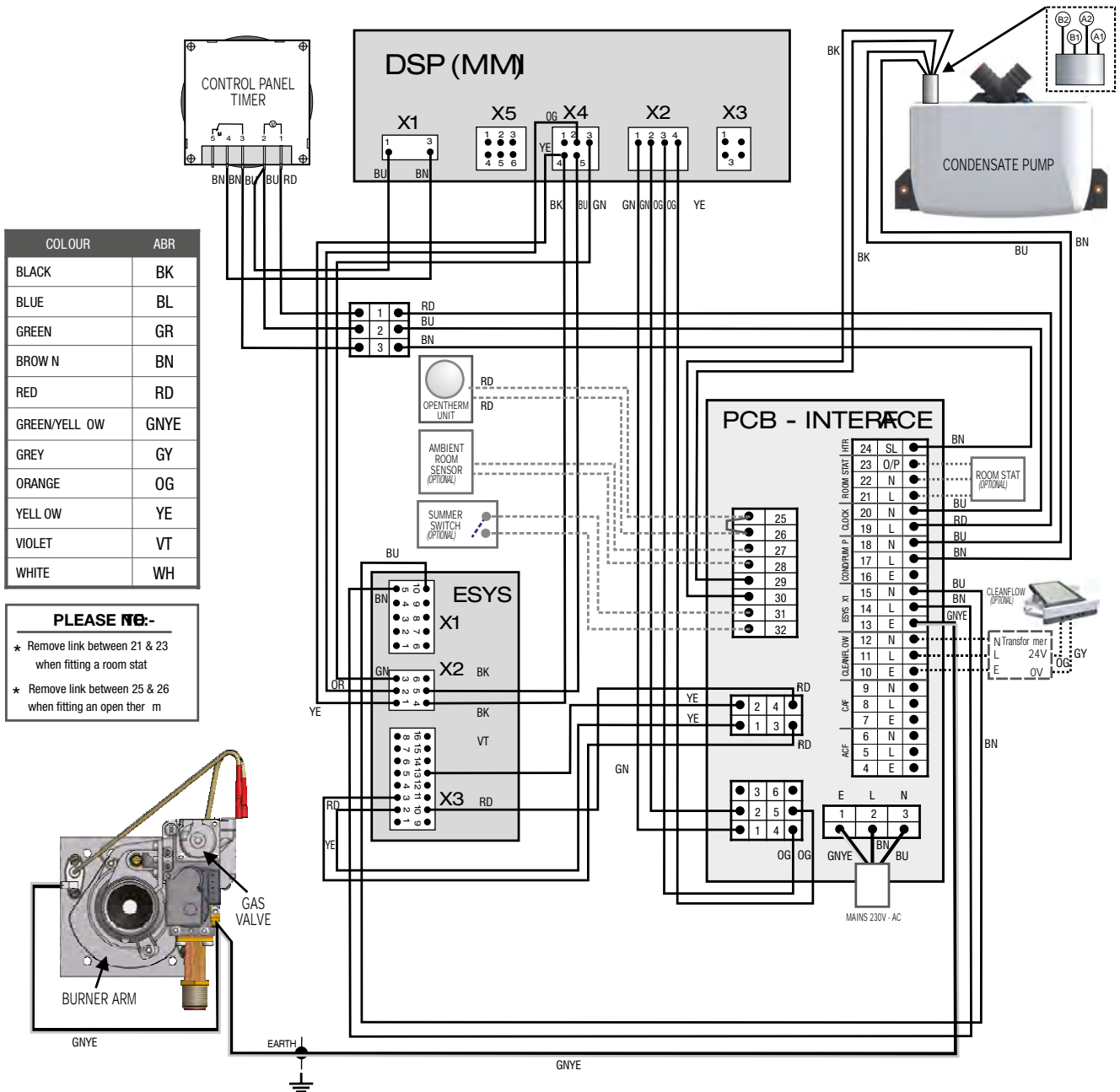


FIGURE 32. WIRING DIAGRAM No. 1 WIRING ROUTING TABLE

FROM UNIT	WIRE COLOUR	TERMINAL	L/N/E	TO UNIT	TERMINAL	
TIMER	red	1	L	PCB INTERFACE	19	
	blue	2	N	PCB INTERFACE	20	
	blue	2		DSP (MMI)	X1 - 1	
	brown	3		PCB INTERFACE	24	
	brown	4		DSP (MMI)	X1 - 3	
DSP (MMI)	green	X2 - 1		PCB INTERFACE	X2 - 1	
	green	X2 - 2		PCB INTERFACE	X2 - 2	
	orange	X2 - 3		PCB INTERFACE	X2 - 4	
	orange	X2 - 4		PCB INTERFACE	X2 - 5	
GAS VALVE	green/yellow	1	E	PCB INTERFACE	13	
	green/yellow	1	E	ELECTRODE		
CLEANFLOW	orange	Transformer	E	PCB INTERFACE	10	
	grey		L	PCB INTERFACE	11	
	-		N	PCB INTERFACE	9	
CONDENSATE PUMP	black	A1		PCB INTERFACE	30	
	black	A2		PCB INTERFACE	29	
	blue	B1	N	PCB INTERFACE	18	
	brown	B2	L	PCB INTERFACE	17	

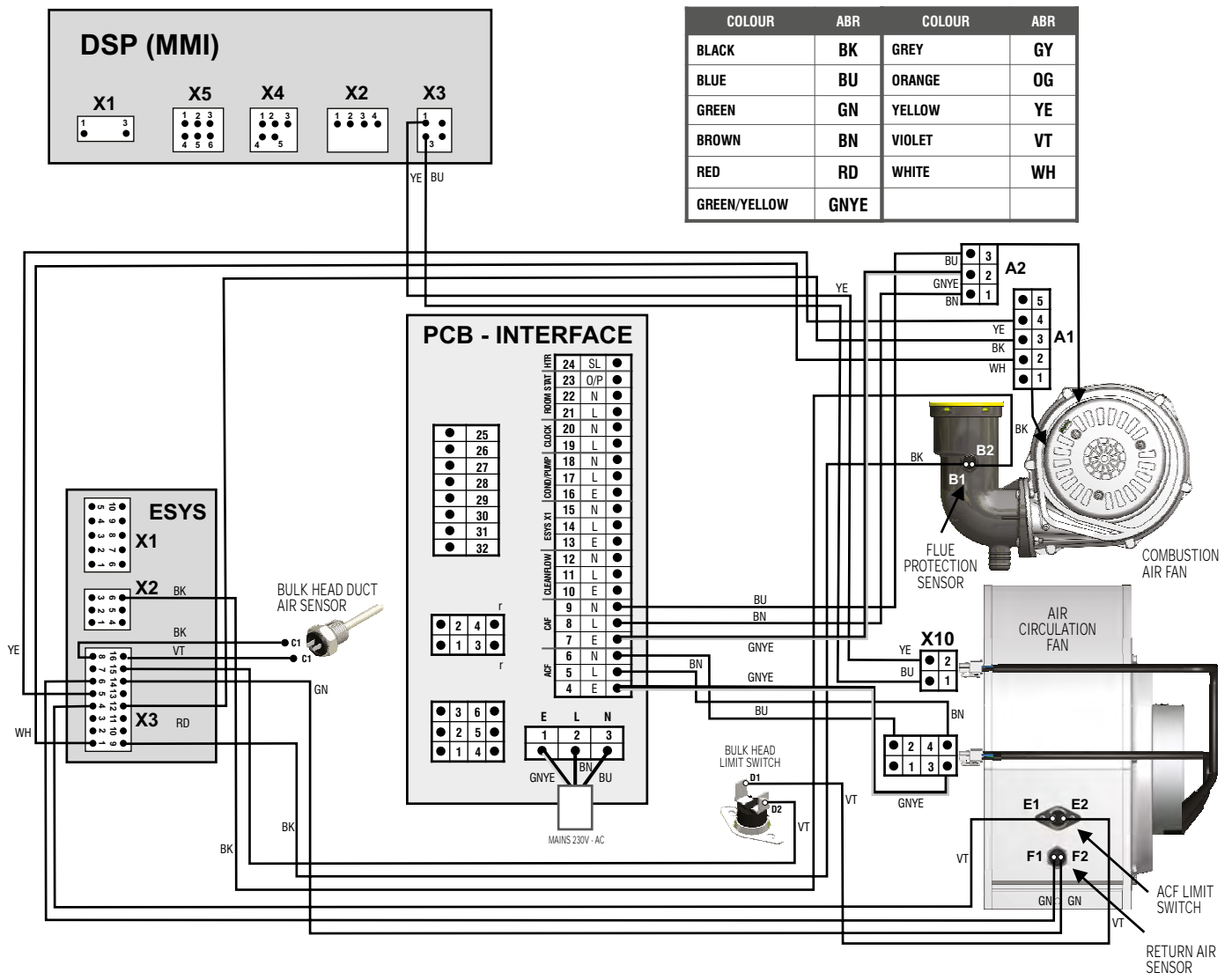


FIGURE 33. WIRING DIAGRAM No. 2 WIRING ROUTING TABLE

FROM UNIT	WIRE COLOUR	TERMINAL	L/N/E	TO UNIT	TERMINAL
COMBUSTION AIR FAN (CAF)	white	A1 - 2		ESYS	X3 - 1
	black	A1 - 3		ESYS	x3 - 12
	yellow	A1 - 4		ESYS	X3 - 5
	brown	A2 - 1	L	PCB INTERFACE	8
	green/yellow	A2 - 2	N	PCB INTERFACE	7
	blue	A1 - 3	E	PCB INTERFACE	9
CAF FLUE PROTECTION SENSOR	black	B1		ESYS	X3 - 9
	black	B2		ESYS	X2 - 6
BULKHEAD LIMIT SWITCH	purple	D1		ACF LIMIT SWITCH	E2
	purple	D2		ESYS	15
BULKHEAD DUCT AIR SENSOR	orange	C1		ESYS	X3 - 8
	orange	C2		ESYS	X3 - 16
AIR CIRCULATION FAN (ACF)	blue	X9 - 2	N	PCB INTERFACE	6
	green/yellow	X9 - 3	E	PCB INTERFACE	4
	brown	X9 - 4	L	PCB INTERFACE	5
	black	X10 - 1		DSP (MMI)	X3 - 3
	yellow	X10 - 2		DSP (MMI)	X3 - 1
ACF LIMIT SWITCH	purple	E1		ESYS	X3 - 4
	purple	E2		BULKHEAD LIMIT SWITCH	D1
ACF RETURN AIR SENSOR	green	F1		ESYS	X3 - 6
	green	F2		ESYS	X3 - 14



## 23. DIMENSIONS

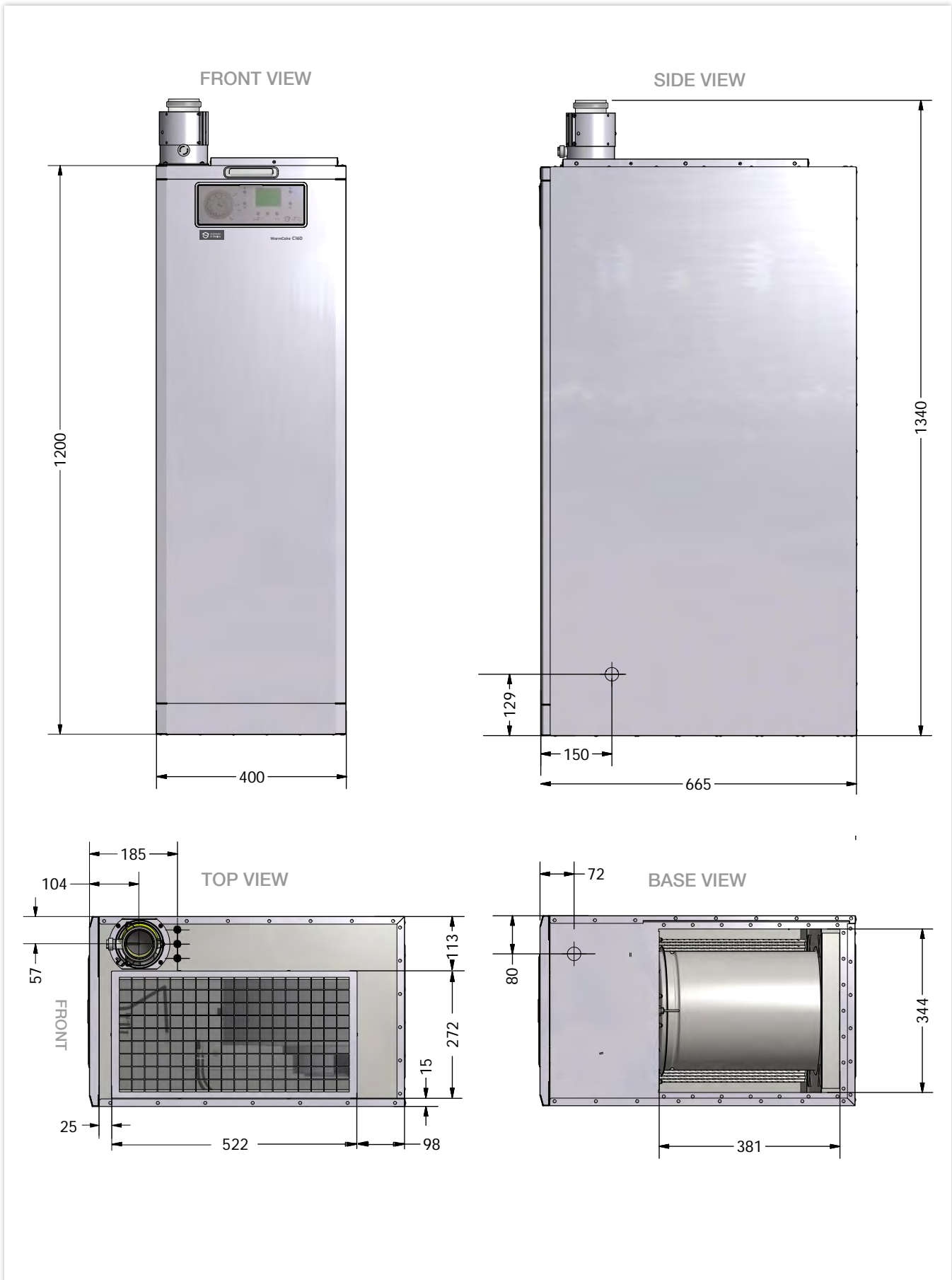


FIGURE 34. WARMCAIR C16D DIMENSIONS

## 24. EXPLODED SPARES DIAGRAMS

ITEM	DESCRIPTION	QTY	PART No.	G. C. No.	
1	<b>CONTROL PANEL ASSEMBLY</b>	1	C10D-0501005		
2	<b>COMBUSTION AIR FAN (CAF) ASSEMBLY</b> <i>Includes 3 &amp; 4</i>	1	1000-0525215	J24-837	
3	CAF GASKET SEALING RING	1	1000-1507865	H36-837	
4	CAF 'O' RING	1	1000-2501675	J24-909	
5	<b>EXHAUST FLUE ELBOW ASSEMBLY</b> <i>Includes 6 &amp; 7</i>	1	1000-0022195	J24-836	
6	FLUE SEAL	1	1000-2501505	J24-833	
7	FLUE GAS SENSOR	1	1000-0522645	J24-836	
8	<b>GAS VALVE/VENTURI</b> <i>Includes 9 &amp; 10</i>	1	1000-0710495	J24-773	
9	VENTURI GASKET	1	1000-1508285	J24-771	
10	CORK GASKET	2	1000-2501175	H38-674	
11	<b>BURNER ARM ASSEMBLY</b> <i>Includes 12 &amp; 13</i>	1	1000-0710215	J24-762	
12	BURNER GASKET A	1	1000-1508165	J24-765	
13	BURNER GASKET B	1	1000-1508175	J24-767	
14	<b>IGNITION ELECTRODE ASSEMBLY</b> <i>Includes 15</i>	1	1000-0710455	J24-780	
15	ELECTRODE GASKET	1	1000-2501275	J24-755	
16	<b>DETECTION ELECTRODE ASSEMBLY</b> <i>Includes 15</i>	1	1000-0710445	J24-769	

ITEM	DESCRIPTION	QTY	PART No.	G. C. No.	
17	<b>AIR CIRCULATION FAN ASSEMBLY</b>	1	C16D-0503005	J24-887	
18	<b>FAN FAILURE SENSOR</b>	1	1000-0517635		
18	<b>RETURN AIR SENSOR DUCT TEMPERATURE SENSOR FLUE GAS SENSOR</b>	1	1000-05222645	J24-833	
19	<b>COMBUSTION AIR BOX ASSEMBLY</b> <i>Includes 21 &amp; 22</i>	1	C16D-0139005	J24-826	
21	<b>SEALING RING</b>	1	1000-2501685	J24-825	
22	<b>CONNECTOR SEAL</b>	1	1000-2501715		
23	<b>CONDENSATE PUMP</b>	1	C10D-0190005	J24-893	
24	<b>HEAT EXCHANGER</b> <i>Includes 21</i>	1	C16D-0330005		
26	<b>ELECTRICAL P.C.B. BOARD</b> <i>Includes 27</i>	1	1000-0526615	J24-838	
27	<b>LOCKING CIRCUIT BOARD SUPPORTS</b>	4	1000-0526485		

ITEM	DESCRIPTION	QTY	PART No.	G. C. No.	
28	HIGH LIMIT TEMPERATURE SENSOR	1	1000-0516835		
29	ESYS CONTROL BOX	1	1000-0526535	J24-895	
30	ESYS SCREW	1	1000-3004035	J24-855	
31	ESYS COVER	1	1000-0522610	J24-856	
33	CONDENSATE TRAP	1	1000-0024525	J24-749	
34	VERTICAL FLUE ADAPTER 60/100mm	1	1000-0022255	J24-784	
35	TELESCOPIC FLUE	1	1000-0022225	J24-811	
36	OPEN THERM SWITCH	1	1000-0525305		

## 26. LIST OF ANCILLARIES

	Description	Product Code	Product Code
1	<b>CLEANFLOW AIR FILTER</b>	CF16	
2	<b>FILTER REPLACEMENT PADS</b> <i>(Pack of 6)</i>	A0212X0212	
3	<b>CLEANFLOW TRANSITION KIT</b>	CTK16	
4	<b>RETURN AIR KIT</b> <i>Includes 4 &amp; 5</i>	RAK16	
5	<b>FLEXIBLE DUCTING</b>	1000-0001390	
6	<b>QUICK RELEASE DUCT CLIP</b>	1000-0013770	
7	<b>SLOT FIX PANELS</b>	<b>TS16</b>	
8	<b>SLOT FIX &amp; GRILLE</b>	<b>TSG16</b>	
9	<b>TOP CLOSURE PANELS</b>	<b>TC16</b>	
10	<b>TOP CLOSURE 2 PANEL KIT</b>	<b>TP16</b>	
13	<b>BASE DUCT</b>	<b>WBX16</b>	

# Benchmark Commissioning & Guarantee Validation Service Record

It is a requirement that the boiler is installed and commissioned to the manufacturers' instructions and the data fields on the commissioning checklist completed in full.

To instigate the boiler guarantee the boiler needs to be registered with the manufacturer within one month of the installation. The guarantee rests with the end-user (consumer), and they should be made aware it is ultimately their responsibility to register with the manufacturer, within the allotted time period.

It is essential that the boiler is serviced in line with the manufacturers' recommendations, at least annually. This must be carried out by a competent Gas Safe registered engineer. The service details should be recorded on the Benchmark Service and Interim Boiler Work Record and left with the householder. Failure to comply with the manufacturers' servicing instructions and requirements will invalidate the guarantee.



[www.hhic.co.uk](http://www.hhic.co.uk)

**This Commissioning Checklist is to be completed in full by the competent person who commissioned the boiler as a means of demonstrating compliance with the appropriate Building Regulations and then handed to the customer to keep for future reference.**

Failure to install and commission according to the manufacturers' instructions and complete this Benchmark Commissioning Checklist will invalidate the guarantee. This does not affect the customer's statutory rights.

\* All installations in England and Wales must be notified to Local Authority Building Control (LABC) either directly or through a Competent Persons Scheme. A Building Regulations Compliance Certificate will then be issued to the customer.

© Heating and Hotwater Industry Council (HHIC)



[www.centralheating.co.uk](http://www.centralheating.co.uk)

## CONDENSING WARM AIR COMMISSIONING CHECKLIST AND GUARANTEE VALIDATION RECORD

Address:											
Warm Air Heater make and model:											
Warm Air Heater serial number:											
Commissioned by (PRINT NAME):						Gas Safe registration number:					
Company name:						Telephone number:					
Company email:						Company address:					
										Commissioning date:	
Heating and hot water systems complies with the appropriate Building Regulations?											Yes
Optional: Building Regulations Notification Number (if applicable)											
Time, temperature control and boiler interlock provided for central heating and hot water:											Yes
<b>WATER QUALITY (DW Models)</b>											
The system has been flushed, cleaned and a suitable inhibitor applied upon final fill, in accordance with BS7593 and the warm air heater manufacturers instructions.											Yes
What system cleaner was used?				Brand:				Product:			
What inhibitor was used?				Brand:				Product:			
Primary water system filter		Pre-existing		Fitted		Not required					
<b>CENTRAL HEATING MODE measure and record (as appropriate)</b>											
Gas rate (for combination boilers complete DHW mode gas rate)						m <sup>3</sup> /hr		or		ft <sup>3</sup> /hr	
Central heating output left at factory settings?						Yes		No			
If no, what is the maximum central heating output selected?										kW	
Dynamic gas inlet pressure										mbar	
Central heating flow temperature										°C	
Central heating return temperature										°C	
System correctly balanced/rebalanced?								Yes			
<b>DOMESTIC HOT WATER MODE Measure and record (DW Models)</b>											
Gas rate						m <sup>3</sup> /hr		or		ft <sup>3</sup> /hr	
Dynamic gas inlet pressure at maximum rate										mbar	
Cold water inlet temperature										°C	
Hot water has been checked at all outlets						Yes		Temperature		°C	
<b>CONDENSATE DISPOSAL</b>											
The condensate drain has been installed in accordance with the manufacturers' instructions and / or BS5546/BS6798											Yes
Point of termination				Internal		External (only where internal termination impractical)					
Method of disposal				Gravity		Pumped					
<b>ALL INSTALLATIONS</b>											
Record the following		At max rate		CO ppm		CO <sub>2</sub> %		CO/CO <sub>2</sub> Ratio			
		At min rate (where possible)		CO ppm		CO <sub>2</sub> %		CO/CO <sub>2</sub> Ratio			
Where possible, has the flue integrity check been undertaken in accordance with the manufacturers' instructions and/or BS5546/BS6798 and are readings correct											Yes
The operation of the heater and system controls have been demonstrated to and understood by the customer											Yes
The manufacturers' literature, including Benchmark Checklist and Service Record, has been explained and left with the customer											Yes
Commissioning Engineer's signature											
Customer's signature (To confirm satisfactory demonstration and receipt of the manufacturers' literature)											

\*All installations in England and Wales must be notified to Local Authority Building Control (LABC) either directly or through a Competent Persons Scheme. A Building Regulations Compliance Certificate will then be issued to the customer

Heating and Hotwater Industry Council (HHIC)



[www.centralheating.co.uk](http://www.centralheating.co.uk)

# SERVICE RECORD

It is recommended that your heating system is serviced regularly and that the appropriate Service Interval Record is completed.

## Service Provider

Before completing the appropriate Service Record below, please ensure you have carried out the service as described in the manufacturer's instructions. Always use the manufacturer's specified spare part when replacing controls.

<b>SERVICE 01</b>		Date:	
Engineer name:			
Company name:			
Telephone No:			
Gas safe register No:			
Record:	At max. rate:	CO ppm	<b>AND</b> CO <sub>2</sub> %
	At min. rate: (Where Possible)	CO ppm	<b>AND</b> CO <sub>2</sub> %
Comments:			
Signature			

<b>SERVICE 02</b>		Date:	
Engineer name:			
Company name:			
Telephone No:			
Gas safe register No:			
Record:	At max. rate:	CO ppm	<b>AND</b> CO <sub>2</sub> %
	At min. rate: (Where Possible)	CO ppm	<b>AND</b> CO <sub>2</sub> %
Comments:			
Signature			

<b>SERVICE 03</b>		Date:	
Engineer name:			
Company name:			
Telephone No:			
Gas safe register No:			
Record:	At max. rate:	CO ppm	<b>AND</b> CO <sub>2</sub> %
	At min. rate: (Where Possible)	CO ppm	<b>AND</b> CO <sub>2</sub> %
Comments:			
Signature			

<b>SERVICE 04</b>		Date:	
Engineer name:			
Company name:			
Telephone No:			
Gas safe register No:			
Record:	At max. rate:	CO ppm	<b>AND</b> CO <sub>2</sub> %
	At min. rate: (Where Possible)	CO ppm	<b>AND</b> CO <sub>2</sub> %
Comments:			
Signature			

<b>SERVICE 05</b>		Date:	
Engineer name:			
Company name:			
Telephone No:			
Gas safe register No:			
Record:	At max. rate:	CO ppm	<b>AND</b> CO <sub>2</sub> %
	At min. rate: (Where Possible)	CO ppm	<b>AND</b> CO <sub>2</sub> %
Comments:			
Signature			

<b>SERVICE 06</b>		Date:	
Engineer name:			
Company name:			
Telephone No:			
Gas safe register No:			
Record:	At max. rate:	CO ppm	<b>AND</b> CO <sub>2</sub> %
	At min. rate: (Where Possible)	CO ppm	<b>AND</b> CO <sub>2</sub> %
Comments:			
Signature			

<b>SERVICE 07</b>		Date:	
Engineer name:			
Company name:			
Telephone No:			
Gas safe register No:			
Record:	At max. rate:	CO ppm	<b>AND</b> CO <sub>2</sub> %
	At min. rate: (Where Possible)	CO ppm	<b>AND</b> CO <sub>2</sub> %
Comments:			
Signature			

<b>SERVICE 08</b>		Date:	
Engineer name:			
Company name:			
Telephone No:			
Gas safe register No:			
Record:	At max. rate:	CO ppm	<b>AND</b> CO <sub>2</sub> %
	At min. rate: (Where Possible)	CO ppm	<b>AND</b> CO <sub>2</sub> %
Comments:			
Signature			

<b>SERVICE 09</b>		Date:	
Engineer name:			
Company name:			
Telephone No:			
Gas safe register No:			
Record:	At max. rate:	CO ppm	<b>AND</b> CO <sub>2</sub> %
	At min. rate: (Where Possible)	CO ppm	<b>AND</b> CO <sub>2</sub> %
Comments:			
Signature			

<b>SERVICE 10</b>		Date:	
Engineer name:			
Company name:			
Telephone No:			
Gas safe register No:			
Record:	At max. rate:	CO ppm	<b>AND</b> CO <sub>2</sub> %
	At min. rate: (Where Possible)	CO ppm	<b>AND</b> CO <sub>2</sub> %
Comments:			
Signature			

\*All installations in England and Wales must be notified to Local Authority Building Control (LABC) either directly or through a Competent Persons Scheme. A Building Regulations Compliance Certificate will then be issued to the customer.





# SERVICE RECORD

It is recommended that your heating system is serviced regularly and that the appropriate Service Interval Record is completed.

## Service Provider

Before completing the appropriate Service Record below, please ensure you have carried out the service as described in the manufacturer's instructions. Always use the manufacturer's specified spare part when replacing controls.

<b>SERVICE 11</b>					Date:
Engineer name:					
Company name:					
Telephone No:					
Gas safe register No:					
Record:	At max. rate:	CO	ppm	<b>AND</b>	CO <sub>2</sub> %
	At min. rate: (Where Possible)	CO	ppm	<b>AND</b>	CO <sub>2</sub> %
Comments:					
Signature					

<b>SERVICE 12</b>					Date:
Engineer name:					
Company name:					
Telephone No:					
Gas safe register No:					
Record:	At max. rate:	CO	ppm	<b>AND</b>	CO <sub>2</sub> %
	At min. rate: (Where Possible)	CO	ppm	<b>AND</b>	CO <sub>2</sub> %
Comments:					
Signature					

<b>SERVICE 13</b>					Date:
Engineer name:					
Company name:					
Telephone No:					
Gas safe register No:					
Record:	At max. rate:	CO	ppm	<b>AND</b>	CO <sub>2</sub> %
	At min. rate: (Where Possible)	CO	ppm	<b>AND</b>	CO <sub>2</sub> %
Comments:					
Signature					

<b>SERVICE 14</b>					Date:
Engineer name:					
Company name:					
Telephone No:					
Gas safe register No:					
Record:	At max. rate:	CO	ppm	<b>AND</b>	CO <sub>2</sub> %
	At min. rate: (Where Possible)	CO	ppm	<b>AND</b>	CO <sub>2</sub> %
Comments:					
Signature					

<b>SERVICE 15</b>					Date:
Engineer name:					
Company name:					
Telephone No:					
Gas safe register No:					
Record:	At max. rate:	CO	ppm	<b>AND</b>	CO <sub>2</sub> %
	At min. rate: (Where Possible)	CO	ppm	<b>AND</b>	CO <sub>2</sub> %
Comments:					
Signature					

<b>SERVICE 16</b>					Date:
Engineer name:					
Company name:					
Telephone No:					
Gas safe register No:					
Record:	At max. rate:	CO	ppm	<b>AND</b>	CO <sub>2</sub> %
	At min. rate: (Where Possible)	CO	ppm	<b>AND</b>	CO <sub>2</sub> %
Comments:					
Signature					

<b>SERVICE 17</b>					Date:
Engineer name:					
Company name:					
Telephone No:					
Gas safe register No:					
Record:	At max. rate:	CO	ppm	<b>AND</b>	CO <sub>2</sub> %
	At min. rate: (Where Possible)	CO	ppm	<b>AND</b>	CO <sub>2</sub> %
Comments:					
Signature					

<b>SERVICE 18</b>					Date:
Engineer name:					
Company name:					
Telephone No:					
Gas safe register No:					
Record:	At max. rate:	CO	ppm	<b>AND</b>	CO <sub>2</sub> %
	At min. rate: (Where Possible)	CO	ppm	<b>AND</b>	CO <sub>2</sub> %
Comments:					
Signature					

<b>SERVICE 19</b>					Date:
Engineer name:					
Company name:					
Telephone No:					
Gas safe register No:					
Record:	At max. rate:	CO	ppm	<b>AND</b>	CO <sub>2</sub> %
	At min. rate: (Where Possible)	CO	ppm	<b>AND</b>	CO <sub>2</sub> %
Comments:					
Signature					

<b>SERVICE 20</b>					Date:
Engineer name:					
Company name:					
Telephone No:					
Gas safe register No:					
Record:	At max. rate:	CO	ppm	<b>AND</b>	CO <sub>2</sub> %
	At min. rate: (Where Possible)	CO	ppm	<b>AND</b>	CO <sub>2</sub> %
Comments:					
Signature					

\*All installations in England and Wales must be notified to Local Authority Building Control (LABC) either directly or through a Competent Persons Scheme. A Building Regulations Compliance Certificate will then be issued to the customer.



**NOTES:**

A large rectangular area with a dotted border, intended for writing notes.

**NOTES:**

A large rectangular area with a dotted border, intended for writing notes.



**Johnson & Starley Ltd**  
Rhosili Road, Brackmills,  
Northampton NN4 7LZ

[sales@johnsonandstarley.co.uk](mailto:sales@johnsonandstarley.co.uk)  
[customer.service@johnsonandstarley.co.uk](mailto:customer.service@johnsonandstarley.co.uk)  
[service@johnsonandstarley.co.uk](mailto:service@johnsonandstarley.co.uk)  
[marketing@johnsonandstarley.co.uk](mailto:marketing@johnsonandstarley.co.uk)

**Reception/Customer Service**  
01604 762881

