



sustainable solutions **under one roof**

HEATING / HOT WATER / VENTILATION

Publication No. ZZ 0941-9  
June 2016

# HI-SPEC J65

## Warm Air Heater

with Modairflow or  
Non Modairflow Control



INSTALLATION, COMMISSIONING  
& SERVICING INSTRUCTIONS

**Hi-Spec J65** - G.C. No. 42-451-14

These instructions are to be left with the User



[www.johnsonandstarley.co.uk](http://www.johnsonandstarley.co.uk)

## CONTENTS

The Benchmark Scheme	2	9 Defect Diagnosis	18
1 General Description	3	10 Fault Finding	20
2 Heater Compartment & Clearances	4	11 Wiring Diagrams	24
3 Ventilation & Combustion Air	4	12 Functional Diagrams	26
4 Duct System	5	13 Dimensions	28
<i>Return Air</i>		14 Notes	29
<i>Warm Delivered Air</i>		15 Short List of Spares	30
5 Installation Requirements	6	16 Exploded Diagram	31
<i>Flues</i>		17 Information & Ancillaries	32
<i>Calculation Method for Flue Sizing</i>		18 Code of Practice	33
<i>Electrical</i>		19 Benchmark Checklist	34
<i>Gas</i>			
6 Commissioning	10		
<i>Preparation</i>			
<i>System Balancing</i>			
<i>Ignition of Pilot &amp; Main Burner</i>			
<i>Main Burner Pressure Test</i>			
<i>Extinguishing of Pilot &amp; Main Burner</i>			
<i>Temperature Rise Check</i>			
<i>Automatic Control Check</i>			
<i>Safety Check</i>			
7 Instructions For User	13		
8 Maintenance	14		
<i>Routine Maintenance</i>			
<i>Burner &amp; Control Assembly Removal</i>			
<i>Burner &amp; Control Assembly Cleaning</i>			
<i>Main Injections Removal, Cleaning &amp; Replacement</i>			
<i>Pilot Burner, Thermocouple &amp; Electrode Removal &amp; Replacement</i>			
<i>Multi-functional Control Removal</i>			
<i>Piezo Unit Removal</i>			
<i>Air Circulation Fan Removal &amp; Cleaning</i>			
<i>Electrical Assembly Removal</i>			
<i>Electronic Module Removal (Modairflow only)</i>			
<i>Transformer Removal (Modairflow only)</i>			
<i>Time Control Removal</i>			
<i>Fan Control, Limit Switch &amp; Airflow Sensor Removal</i>			
<i>Spillage Monitoring Device (TTB) Removal</i>			
<i>Heat Exchanger Access</i>			



### THESE INSTRUCTIONS SHOULD BE LEFT WITH THE USER AFTER INSTALLATION

#### The Benchmark Scheme

Johnson & Starley Ltd is a licensed member of the Benchmark Scheme which aims to improve the standards of installation and commissioning of domestic heating and hot water systems in the UK and to encourage regular servicing to optimise safety, efficiency and performance.

Benchmark is managed and promoted by the Heating and Hotwater Industry Council. For more information visit [www.centralheating.co.uk](http://www.centralheating.co.uk)

Please ensure that the installer has fully completed the Benchmark Checklist on the inside back pages of the installation instructions supplied with the product and that you have signed it to say that you have received a full and clear explanation of its operation. The installer is legally required to complete a commissioning checklist as a means of complying with the appropriate Building Regulations (England and Wales).

All installations must be notified to Local Area Building Control either directly or through a Competent Persons Scheme. A Building Regulations Compliance Certificate will then be issued to the customer who should, on receipt, write the Notification Number on the Benchmark Checklist.

This product should be serviced regularly to optimise its safety, efficiency and performance. The service engineer should complete the relevant Service Record on the Benchmark Checklist after each service.

The Benchmark Checklist will be required in the event of any warranty work and as supporting documentation relating to home improvements in the optional documents section of the Home Improvements.

**In the interest of continuous development Johnson and Starley reserve the right to change specification without prior notice. Johnson and Starley prides itself on it's ability to supply spare parts quickly and efficiently.**

## 1. GENERAL DESCRIPTION

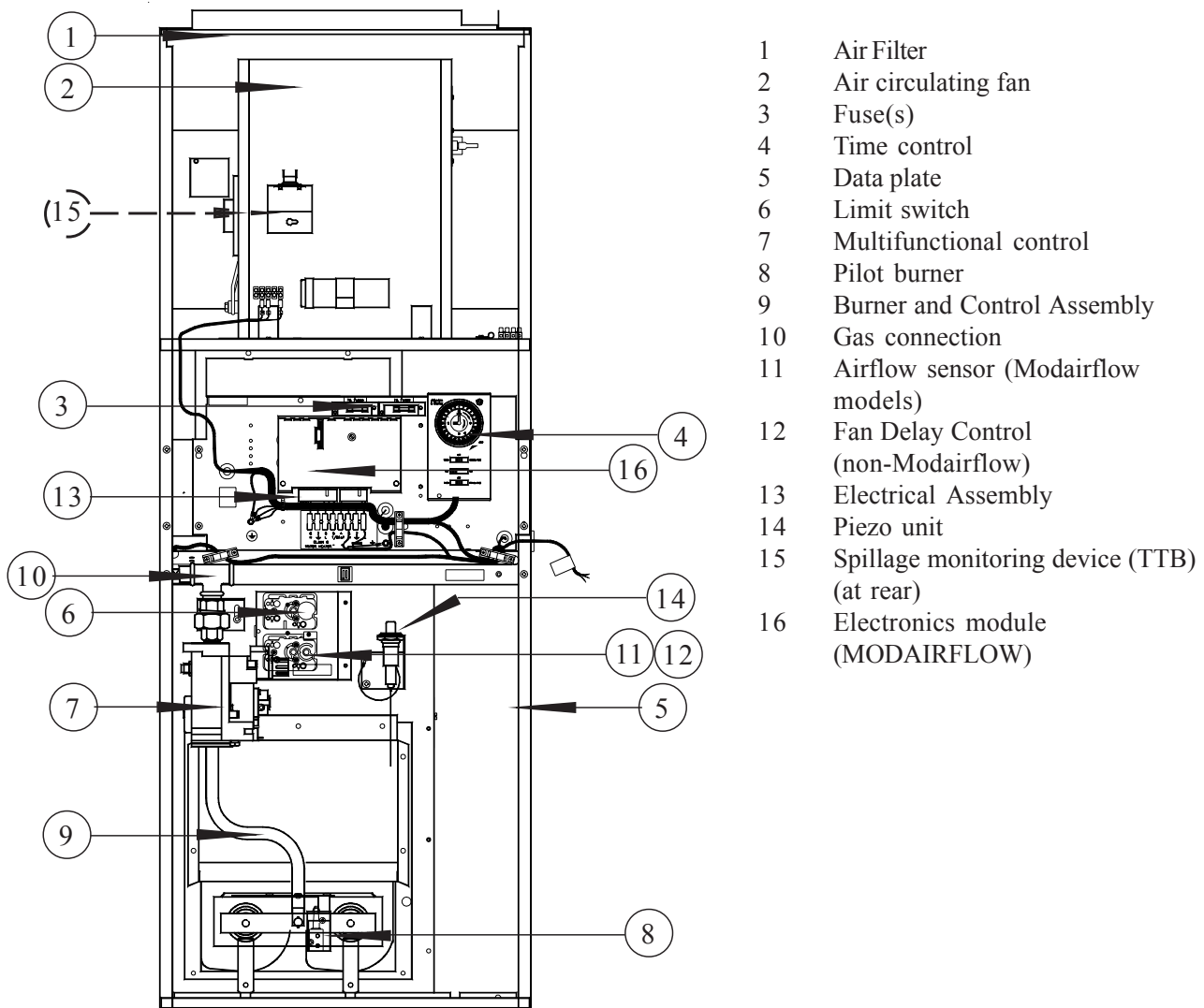

**Fig. 1**

- 1.1 HI-SPEC J65 is an open-flued, fan assisted downflow, ducted warm air heater, which may be supplied with MODAIRFLOW control and in conjunction with an ELJAN 6 water circulator. A non-MODAIRFLOW version is available as an option. A Spillage Monitoring Device (TTB) is fitted which senses the temperature in the draught diverter, and shuts down the appliance when this temperature rises due to the presence of flue gases.
- 1.2 The Air heater output can be adjusted between 16.1kW (58.0MJ/h, 55,000Btu/h) and 19.1kW (68.6MJ/h, 65,000Btu/h). "Summer air circulation" of unheated air is available by manual selection (see User's Instructions). ELJAN 6 output is 3.32kW (11.5MJ/h, 11,340Btu/h).

THIS APPLIANCE CONFORMS TO BS EN 55014

**Installation shall be in accordance with the current editions of:-**

Building Standards (Scotland) (Consolidation) Regulations

Building Regulations

Gas Safety (Installation and Use) Regulations (as amended)

BS 7671 Institute of Electrical Engineers (I.E.E.) Wiring Regulations

BS 6891 Installation of Low Pressure Gas Pipework of up to 28mm (R1) in domestic premises (2nd family gases).

BS 5440 Pt. 1 (Flues for Gas Appliances)

BS 5440 Pt. 2 (Air Supply for Gas Appliances)

BS 5864 Installation of Gas Fired Ducted Air Heaters

Model and Local Authority Bye-laws

**IMPORTANT: STATUE LAW DEFINES THAT ALL GAS APPLIANCES MUST BE INSTALLED COMPETENT PERSONS, i.e. GAS SAFE REGISTERED INSTALLERS. GAS SAFE MEMBERSHIP ENQUIRIES TEL: 0800 408 5500 IN ACCORDANCE WITH THE GAS SAFETY (INSTALLATION AND USE) REGULATIONS (CURRENT EDITION). FAILURE TO COMPLY WITH THESE REGULATIONS MAY LEAD TO PROSECUTION.**

**2. HEATER COMPARTMENT AND CLEARANCES (See BS 5864**

- 2.1 **IMPORTANT:** If the heater is to be fitted to an existing base duct (warm air plenum), always ensure that installation is carried out such that the rear left hand corner of the heater is aligned with the rear left hand corner of the base duct, so that any overhang or blanking off will be at the front and/or right hand side. In any event, blanking plates must be mechanically secured and all joints sealed.
- 2.2 When the heater is fitted into a compartment, a minimum clearance from the compartment walls of 38mm (1½in) at the rear, 75mm (3in) total at the sides (with a minimum of 25mm (1in) at any one side), and 63mm (2½in) at the front must be left. Consideration should also be given to the space required for the removal and replacement of the filter tray and the entry of the gas and electrical supplies.
- 2.3 For service access, a minimum of 600mm (24ins) is required at the front of the heater. Space must also be allowed, in a compartment installation, to permit the removal of the heater. The clearance between the appliance and the compartment should not be less than 75mm (3in). However, where clearances are less than 75mm, the internal surface of the compartment must be lined with a non-combustible material. The compartment must be of a fixed rigid structure.
- 2.4 In airing cupboard installations, the part used as the air heater compartment must comply with the relevant section of BS 5864 and must be completely separated by either a non-combustible partition or a perforated metal partition with the perforations not exceeding 13mm (1/2in). The secondary flue must be a tight fit where it passes through the partition and must be suitably protected (see BS 5440:Part 1).
- 2.5 In under-stairs installations, the compartment must comply with the relevant section of BS 5864, provided that in addition, all internal surfaces, including the base, are non-combustible or lined with non-combustible material. This requirement is applicable only to dwellings of more than two storeys.
- 2.6 If the appliance is to be installed onto a combustible surface, a suitable base tray (BT65/90) is required. However, when a base duct is used, this provides sufficient protection for combustible material and no further insulation is required.

**3. VENTILATION AND COMBUSTION AIR**

- 3.1 The room or internal space in which the heater is installed requires a permanent air vent of minimum effective area 101cm<sup>2</sup> (16in<sup>2</sup>). The air vent should be either direct to outside air or to an adjacent room or internal space (other than a toilet or bathroom) that itself has an equivalent air vent direct to outside.
- 3.2 Combustion air may be introduced, via a 125mm (5in) nominal bore pipe, connected to a return air duct or plenum from a ventilated area and fitted with a lockable damper. The damper should be adjusted to control combustion airflow to 0.017m<sup>3</sup>/s (36cfm), (i.e. 1.39m/s {275ft/min} velocity in a 125mm [5in] bore pipe). If this arrangement is used, a non-closeable warm air register **MUST** be provided in the same area as the front of the air heater or heater compartment if a return air grille is not located in that area.
- 3.3 When installed in a compartment, two permanent ventilation openings into the compartment are required, one at high level and one at low level, both communicating either directly with outside air or with a ventilated room or space. The minimum effective areas specified in Table 1 are related to the rated heat input of the Air Heater, and assuming that an Eljan 6 circulator is fitted.
- 3.4 If any room or area from which air is drawn for ventilation or combustion contains an extract fan, the permanent vents must be sized to ensure that the operation of the appliance(s) at full rate is/are not adversely affected. A spillage test as specified in sub-para 6.8 (Safety Checks) is carried out and any remedial work undertaken.

VENTILATED FROM INSIDE BUILDING	Low level grille	529cm <sup>2</sup> (80in <sup>2</sup> )
	High level grille	265cm <sup>2</sup> (40in <sup>2</sup> )
VENTILATED FROM OUTSIDE BUILDING	Low level grille	265cm <sup>2</sup> (40in <sup>2</sup> )
	High level grille	132cm <sup>2</sup> (20in <sup>2</sup> )

**Table 1  
Minimum Effective Areas**

## 4.

## DUCT SYSTEM

### 4.1 RETURN AIR

- 4.1.1 All return air shall be POSITIVELY ducted from outside the compartment to the top of the unit via a return air duct, and mechanically secured. It is recommended that the return air duct be not routed directly from the main living area, but from a convenient central area serving the remainder of the dwelling.
- 4.1.2 The return air system should be constructed of fire-resistant material. The flue shall not be run through an area serving as a return air path. It is extremely important that the correct size of return air grilles and ducting is used. For heaters on maximum output the return air duct size should not be less than the equivalent of 300mm x 300mm (12" x 12"). If flexible duct is used the duct diameter should not be less than 350mm (14") dia. The return air grille should have a free area of not less than 1593cm<sup>2</sup> (247in<sup>2</sup>).
- 4.1.3 An adequate and unobstructed return air path is essential from areas not served by a directly ducted return and to which warm air is delivered. All such rooms should be fitted with relief grilles which have a free area of 0.0088m<sup>2</sup>/kW (1in<sup>2</sup>/250Btu/h) of heat supplied to the room. The only exceptions are kitchens, bathrooms and WC.'s.
- 4.1.4 The return air duct should allow for ease of removal for access to the flue.
- 4.1.5 All duct work in the room or internal space in which the heater is installed shall be mechanically secured, and sealed with ducting tape.

### 4.2 WARM DELIVERED AIR

- 4.2.1 All duct work, including riser ducts, should be fully insulated with 50mm (2in) fibreglass or similar. If short extended duct runs are taken below floor level these should be similarly insulated, and in addition wrapped with a sound vapour proof barrier, and protected from crushing.
- 4.2.2 The duct system should be carefully designed (as given in the guidelines in the British System Design Manual) to suit the needs of its specific heating requirements and building layout. The type of duct system, (i.e. radial/extended plenum/stepped) should be installed using the least number of fittings to minimise airflow resistance. The base duct, which equalises the air pressure to supply ducts, shall be constructed to support the weight of the heater, which shall be secured to the plenum with screws on at least two sides, and sealed using self-adhesive foam strip, ducting tape or sealing compound. All ducting and blanking plates shall be mechanically secured and sealed.

## 5. INSTALLATION INSTRUCTIONS

Note: For ELJAN 6 circulator Installation Instructions, see separate instructions ZZ778.

### 5.1 FLUES (see British Standards BS 5440 Pt. 1 Flues)

- 5.1.1 All joints shall be soundly sealed.
- 5.1.2 The flue should be kept as short and warm as possible.
- 5.1.3 Sufficient support brackets shall be installed to bear the weight of the total flue system.
- 5.1.4 The spigot connection of the heater draught diverter will accept internally the spigot end of a non-asbestos flue to BS 567 or twin wall metal flue to BS 715 of nominal 125mm (5in) diameter.
- 5.1.5 A split collar should be fitted to provide for flue maintenance or inspection.
- 5.1.6 The flue shall be in accordance with the Building Regulations and British Gas Materials and Installations specification 3rd edition) with regard to clearance and shielding from combustible materials.
- 5.1.7 All materials shall be in accordance with Building Regulations requirements.
- 5.1.8 The flue should run as vertically as possible. Horizontal runs should be avoided if at all possible and any directional change should be as gentle as possible. If there is any doubt about the flue configuration, the equivalent flue height should be determined (see 5.1.11).
- 5.1.9 If the appliance to be fitted is a replacement, the old appliance should be checked for signs of spillage prior to commencement of the installation and appropriate action taken, (i.e. check flue system and renew as necessary).
- 5.1.10 It is recommended that at least 600mm of vertical flue should be provided from the top of the draught diverter (for new installations this shall be incorporated into the flue design). However, when carrying out replacement installations, an existing flue system may be encountered, where the vertical flue above the appliance to the first bend is less than 600mm. In the first instance, the installer must judge whether this distance can be achieved practicably by some means. Where this is not practicable, the existing flue system may be used, providing there is no evidence of spillage from the old appliance (see 5.1.9 above). Every effort must be made, however, to ensure that the existing flue complies in every other way to BS 5440 Part 1, including the visual inspection, flue flow and spillage test described in 4.3.2 of the above standard. Flue configurations may be assessed in terms of equivalent vertical height - details are given in 5.1.11. For air heaters, the minimum equivalent vertical height is 1 metre. The installer must make a judgement based on his knowledge and experience and the examination and testing described above as to whether an existing flue system can be used.

**Note:** Ventilation of the compartment, room or internal space in which the appliance is to be installed must be checked for compliance with the requirements of BS 5440 Part 2 ( Ref. Section 3 of these instructions) and upgraded as necessary.

#### 5.1.11 Calculation method for flue sizing: ( from BS 5440: Part 1, Appendix A)

- a. This appendix provides a procedure for estimating whether a given flue design is likely to ensure full clearance of combustion products.
- b. The procedure is based on calculating the 'equivalent height' of the flue under consideration, i.e. that height of the straight vertical circular flue pipe of specific size which will produce the same flow rate as the flue under consideration. The equivalent height is calculated from the formula:

$$H_e = H_a \times \frac{(K_i + K_o)_e}{(K_i + K_o)_a - K_e H_a + \text{Sum } K}$$

where:

$H_e$  is the height of the equivalent flue;

$H_a$  is the vertical height of the actual or proposed flue;

$K_i$  is the inlet resistance of the flue;

$K_o$  is the outlet resistance from the flue;

subscript e refers to the equivalent flue diameter;

subscript a refers to the actual or proposed flue diameter;

$K_e$  is the resistance per unit length of the equivalent flue;

Sum K is the resistance (other than the inlet and outlet resistance) of the actual or proposed flue.

**Note:** K and Sum K are obtained from Table 2.  $K_o$  and  $K_i$  are obtained from Table 3.

- c. Table 2 gives resistance factors for common flue components for use in the formula. Table 3 contains the appropriate inlet and outlet flue resistances. **(the flue is likely to be satisfactory if its equivalent height exceeds 1m).**

Component	Internal Size (mm)	Resistance Factor	Component	Internal Size (mm)	Resistance Factor	
Flue Blocks	197 x 67	0.85 per meter	45° Bend	100 mm pipe	0.61 per	
	231 x 65	0.65 run		125 mm pipe	0.25 fitting	
	317 x 63	0.35		150 mm pipe	0.12	
	140 x 102	0.60		197 x 67	0.30	
	200 x 75	0.60		231 x 65	0.22	
	183 x 90	0.45		317 x 63	0.13	
Pipe	100	0.78	Raking block	Any	0.30 per block	
	125	0.25		Adaptor block	Any	0.50
	150	0.12			Terminal	100 mm ridge
Chimney	213 x 213	0.02	125 mm ridge	1.0		
	90° Bend	100 mm pipe	1.22 per	150 mm ridge		0.48
		125 mm pipe	0.50 fitting	100 mm GCI		0.6
150 mm pipe		0.24	125 mm GCI	0.25		
			150 mm GCI	0.12		

**Table 2**  
**Resistance factors for use in calculating equivalent heights**

Appliance	Inlet Resistance (K <sub>i</sub> )	Flue	Outlet Resistance (K <sub>o</sub> )
100 mm dia spigot	2.5	100 mm flue	2.5
125 mm dia spigot	1.0	125 mm flue	1.0
150 mm dia spigot	0.48	150 mm flue	0.48

**Table 3**  
**Inlet and outlet resistance**

d. **Worked Calculation Example:**

A warm air unit with a 100 mm diameter flue spigot, fitted with a pre-fabricated flue system leading to a ridge tile in the loft (refer Fig. 2):

**From table 3:**

K <sub>ia</sub>	Inlet resistance of actual flue	= 2.5
K <sub>oa</sub>	Outlet resistance of actual flue	= 2.5
K <sub>ie</sub>	Inlet resistance of equivalent flue	= 2.5
K <sub>oe</sub>	Outlet resistance of the actual flue	= 2.5

**From table 2:**

Other resistances of actual flue:		
Terminal		= 2.5
Pipe bend ( 2 x 0.61)		= 1.22
Pipe (4 x 1m @ 0.78)		= 3.12
(5 x 0.3m @ 0.78)		= 1.17
<b>Sum K</b>		<b>= 8.01</b>

Equivalent height :

From the formula

$$H_e = 6.2 \times \frac{(2.5 + 2.5)}{(2.5 + 2.5) - (0.78 \times 6.2) + 8.01}$$

**H<sub>e</sub> = 3.793** This flue exceeds 1.0m equivalent height and is therefore satisfactory

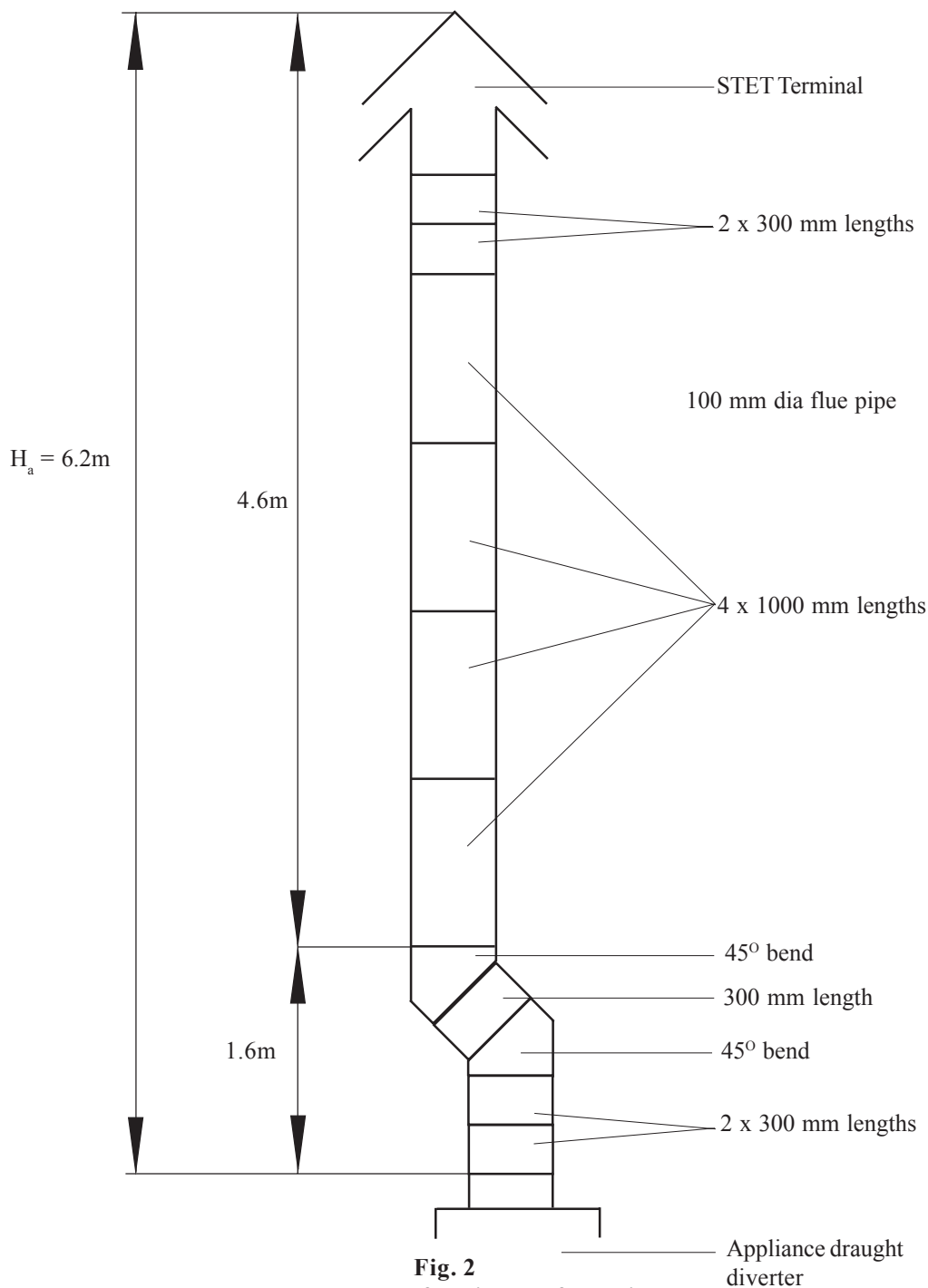

**Fig. 2**  
**Worked example of equivalent flue height**

- 5.1.12 Special consideration must be given to external flues with a view to prevention of condensation and weathering problems.
- 5.1.13 An approved terminal should always be used; a ridge terminal or “GC1” terminal is specifically recommended. The latter should be positioned in a free air space where it is not shielded by any structure. A minimum of 1m (3ft.) from any vertical or inclined roof structure must be allowed for.
- 5.1.14 Where flue blocks are used, builders should ensure that no obstruction is created during erection. The installer should ensure that the connection flue does not project beyond the internal wall of the flue blocks and that there is provision for examination and servicing.
- 5.1.15 **Important:** Before installing the appliance, carry out a visual check of the flue system as directed in the relevant section of BS5440 Pt.1, then check the flue performance as follows:-
- Close all doors and windows in the room in which the appliance is to be installed.
  - Introduce some heat into the flue, using a blow torch or other means.
  - Carry out a flow visualisation check with a smoke pellet at the intended position for the appliance. Ensure that there is discharge of smoke from the correct terminal only, and no spillage into the room. Smoke coming out of other than the correct terminal only, or a down draught or ‘no flow’ condition, indicates that the flue has failed the test, and the appliance shall not be connected until the defect has been found and rectified, and the test satisfactorily completed.



## 5.2 ELECTRICAL

### 5.2.1 Mains.

- a. The heater is supplied with mains cable (PVC sheathed, heat resisting to 85°C), 3-core Brown-Blue-Green/Yellow, 6A, 0.75mm<sup>2</sup>), connected to a terminal block and exiting through the heater at the right hand top front. The cable is suitable for a 230V 50Hz supply and shall be connected to the fixed wiring using a double pole switched, fused spur, incorporating a protective earth link. The fuse fitted shall be rated 5A to BS1362. Connections shall be in accordance with the current edition of I.E.E Regulations BS 7671.
- b. MODAIRFLOW Models: An electronic controller (Thermista-stat) is supplied which acts as a room thermostat.
- c. Non-MODAIRFLOW models: A 24V room thermostat (not supplied), that complies with BS 800, BS 3955 and BS 4201 is essential to ensure close control of comfort conditions. An anticipator is located within the thermostat and is graded in amps. The anticipator should be checked and adjusted to 0.2A.

### 5.2.2 Thermista-stat/Room Thermostat and its location.

- a. The Thermista-stat/Room Thermostat should be located where there is free air circulation approx. 1.5m (5ft) from the floor.
- b. Avoid the following locations:-
  - i) In a room where temperature is greatly affected by the sun or any other heat source, e.g. radiant fire, wall light fittings or TV set.
  - ii) Near an outside door or windows, or on an outside wall.
  - iii) Where affected by warm air ducts, diffusers, waste pipes or the heater itself.
  - iv) Where subject to vibration.
- c. For MODAIRFLOW models, connect Thermista-stat wires to control panel terminals '4' and '5' (see Fig. 5a and 6a), connection polarity being important, connect +ve side on control panel to +ve side on Thermista- stat.
- d. For non-MODAIRFLOW models, connect room thermostat wires control panel terminals '16' and '17'

## 5.3 GAS (See BS 5864 and BS 6891)

- 5.3.1 An independent gas supply pipe from the meter is to be preferred wherever possible. When this is not possible, the pipe must be capable of taking the complete input of the heater and all other gas appliances being served by this same pipe. This supply should be suitably sized to conform to British Standards requirements of no more than 1.0 mbar (0.4in wg) pressure drop (See table of discharge in BS 6891).
- 5.3.2 The 1/2in union gas cock (supplied) must be fitted to the gas inlet of the heater for easy isolation during servicing. The gas pipe should be so fitted and installed as to be durable, substantial and gas tight. To assist in determining where a gas connection may not be tight, a leak detection fluid should be applied around the connection. Under no circumstances should a flame be used to locate a gas leak. Gas entry to the air heater is through either side to a Rc1/2 (1/2in BSP. external [taper] thread).

## 6. COMMISSIONING

### 6.1 PREPARATION:

6.1.1 Ensure that:

- a. Gas and Electrical supplies are **OFF**.
- b. Filter, fan and fan compartments are free from obstructions.
- c. All registers or grilles are open and conform to design specifications.
- d. Return, relief and ventilation air installations are adequate.

### 6.2 SYSTEM BALANCING:

6.2.1 Set the Air Heater electrical supply **ON**.

6.2.2 Set the 'SUMMER AIR CIRCULATION' switch to '**ON**'.

6.2.3 Balance the ducting system to provide the required volume proportions at the warm air outlets.

**NOTE:** If the system includes ceiling diffusers, air velocities through these should be NOT LESS THAN 1.5m/s (300 ft/min), except for very small rooms (i.e., bathrooms etc.). Outlet faces may require partial blanking in order to achieve this.

### 6.3 IGNITION OF PILOT AND MAIN BURNERS:

**WARNING:** If the pilot light is extinguished either intentionally or unintentionally, no attempt should be made to relight the gas for a minimum of 3 minutes. Ensure that the Electrical supply, Time Control and Selector switches are set to '**OFF**'.

6.3.1 Set the Thermista-stat/room thermostat to lowest or **OFF** setting.

6.3.2 On the Multifunctional Control, remove the Outlet Pressure test point cover, and fit a pressure test gauge (refer Fig. 4).

6.3.3 Turn the heater Gas supply **ON**, test for gas soundness and purge the whole gas pipe as described in BS 6891.

6.3.4 Referring to Fig. 4, press and hold the OPERATING CONTROL, and whilst observing the Pilot Burner, repeatedly press Piezo igniter button until Pilot Burner ignites.

6.3.5 After 20 seconds release the OPERATING CONTROL and let it spring out; ensure that the Pilot Burner remains alight. If the Pilot Burner extinguishes, rotate the OPERATING CONTROL clockwise to the '1' position and ensure that the OPERATING CONTROL is fully reset. Wait three minutes and repeat steps 6.3.4 and 6.3.5, holding the OPERATING CONTROL pressed for a longer period, until Pilot Burner remains alight.

6.3.6 Ensure that the pilot flame envelops the thermocouple tip, adjusting the Multifunctional Control Pilot Adjuster as required (refer Fig. 3).

6.3.7 Set the air heater Electricity supply **ON**.

6.3.8 Set the Time Control to the required Heating On periods.

6.3.9 Set the Selector switch to '**TIMED**'.

6.3.10 Set the Thermista-stat or room thermostat to **MAXIMUM**.

6.3.11 Ensure that the main burner has now ignited.

6.3.12 Test for gas leakage at the supply, Multifunctional control, Pilot and Main burners using proprietary detection fluid, sealing any leaks found.

6.3.13 Allow the heater to operate for a minimum of 15 minutes to ensure stability.

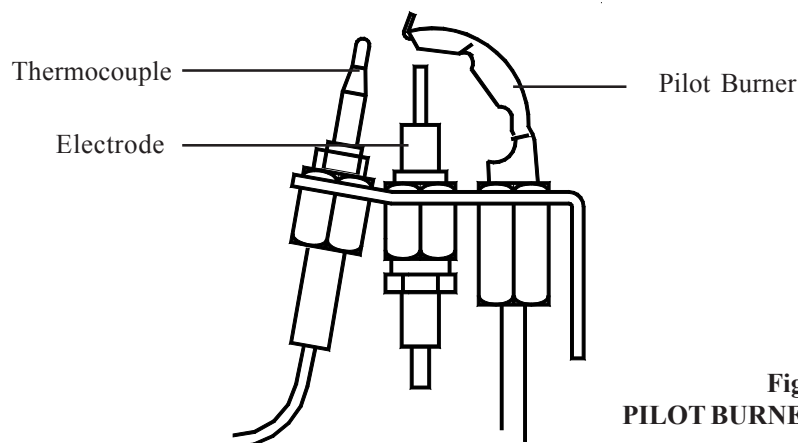

**Fig. 3**  
**PILOT BURNER ASSEMBLY**

## 6.4 MAIN BURNER PRESSURE TEST:

**NOTE: AIR HEATER BURNERS ARE FACTORY SET TO PROVIDE A NOMINAL HIGH RATE OUTPUT AS DETAILED IN SUB PARA 1.2**

- 6.4.1 Referring to Table 4 and Fig. 4 below, ensure that the pressure test gauge indicates the correct burner pressure, resetting if required as follows:
- a. At the Multifunctional Control:
    - i. Remove the Burner Pressure Adjuster cover.
    - ii. Set the Burner Pressure Adjuster to provide a pressure test gauge indication for the correct burner pressure as detailed in Table 4
    - iii. Refit the Burner Pressure Adjuster cover.
- 6.4.2 Apply the pressure set arrow to indicate the appropriate burner pressure on the data badge.

## 6.5 EXTINGUISHING OF BURNERS AND TEMPERATURE RISE TEST:

- 6.5.1 On the Multifunctional Control, rotate the OPERATING CONTROL clockwise to the '1' position and ensure that the OPERATING CONTROL fully resets, and both Pilot and Main Burners are extinguished.
- 6.5.2 On the Multifunctional Control, remove the pressure test gauge and refit the Outlet Pressure test point cover.

## 6.6 TEMPERATURE RISE CHECK:

- 6.6.1 Ignite the Pilot and Main Burners and allow 15 minutes for stability before continuing.
- 6.6.2 With the Main Burner operating continuously, check that the temperature rise across heater is between 45°C - 55°C, setting the fan speed accordingly, (decrease fan speed to increase temperature rise). For MODAIRFLOW heaters, adjusting the balancing screw sets the fan speed; whilst for non-MODAIRFLOW heaters, the fan speed is adjusted by selecting the fan speed at control panel (decrease voltage selection to decrease fan speed).

**Note: Tapping 1 = 170V, Tapping 2 = 180V, Tapping 3 = 195V, Tapping 4 = 210V, Tapping 5 = 230V.**

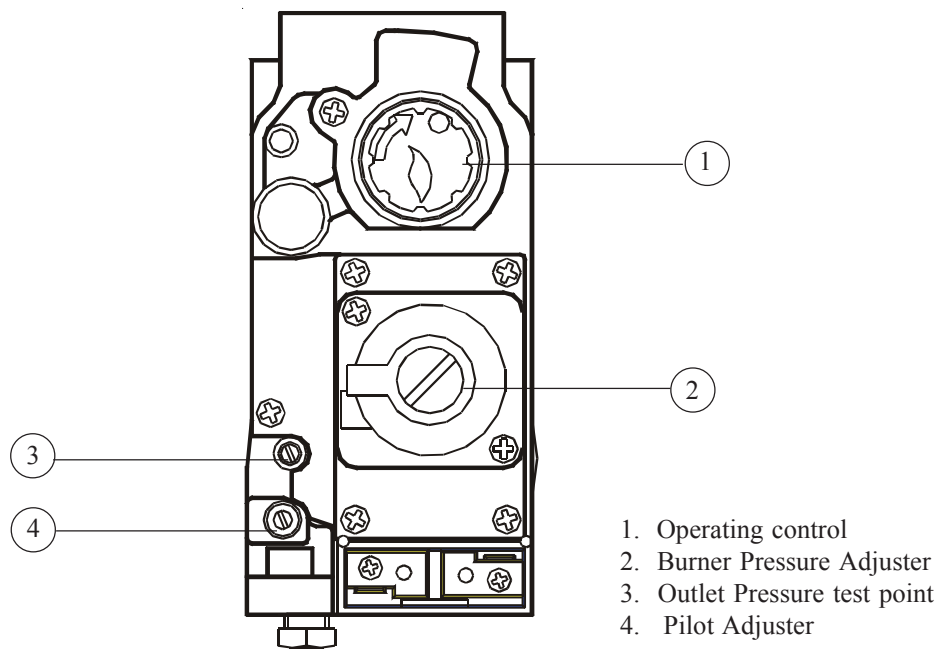

**Fig. 4**  
**MULTIFUNCTIONAL CONTROL**

## 6.7 AUTOMATIC CONTROLS CHECK

- 6.7.1 Set the TIME CONTROL to 'ON'.
- 6.7.2 Turn the Thermosta-stat or room thermostat slowly clockwise until the Main Burner ignites.
- 6.7.3 Ensure that the fan starts to operate after a short period (approx. 1-2 minutes).

### **MODAIRFLOW models:**

- 6.7.4 Ensure that the fan speed increases to full speed.
- 6.7.5 When the temperature reaches the control setting, check that the Main Burner cycles ON and OFF, at approximately 75 to 120 seconds.

**Non-MODAIRFLOW models:**

- 6.7.6 When the temperature reaches the control setting, ensure that the Main Burner extinguishes followed by the fan switching off after a short period.
- 6.7.7 When the temperature falls below the control setting, ensure that the Main Burner re-ignites followed by fan operation.

**6.8 SAFETY CHECKS:**

- 6.8.1 Check for gas soundness within the appliance.
- 6.8.2 **Spillage test:** Carry out a full spillage test as follows, and ensure that the flue operates effectively with all doors closed and any extractor fans in operation.

**NOTE:** If an extractor fan is situated in an adjoining or adjacent room, carry out the spillage test with the interconnecting doors open.

**If the draught diverter is accessible:**

- a. Introduce smoke into the draught diverter adjacent to an exit from the heat exchanger, by means a smoke match or puffer.
- b. Ensure that there is no spillage present (indicated by displacement of smoke downwards and out of the draught diverter).

**If the Draught Diverter is not accessible:**

- a. Introduce smoke, by means of **part** of a smoke pellet on a non-combustible support, into the heat exchanger.
- b. Extinguish the Main and Pilot burners.
- c. Ensure that there is no spillage evident by visually observing the draught diverter location on the air heater.
- d. If spillage is evident, further investigation and rectification is required before re-testing the appliance.
- e. **Repeat spillage tests but with the fan running, or Summer Airflow switch set to ON.**

**WARNING: The appliance shall not be left connected to the gas supply unless it has successfully passed the above spillage test.**

- 6.8.3 Turn OFF the gas supply at the service cock and ensure that the Multifunctional Control fail-safe operates within 60 secs (indicated by loud click from Multifunctional Control).
- 6.8.4 Turn the gas supply ON at the service cock.
- 6.8.5 Switch the electrical supply to the appliance OFF.
- 6.8.6 **MODAIRFLOW models**, disconnect the air circulation fan at the flying socket
- 6.8.7 **Non-MODAIRFLOW models**, disconnect the air circulation fan at the electrical control panel.
- 6.8.8 Switch the electrical supply to the appliance ON.
- 6.8.9 Ignite the Main and Pilot Burners as detailed in sub para 6.3.1 to 6.3.5
- 6.8.10 Ensure that the Limit Switch operates, indicated by the Main Burner extinguishing, within 120 and 180 seconds.
- 6.8.11 Switch the electrical supply to the appliance OFF.
- 6.8.12 Reconnect the air circulation fan.
- 6.8.13 Switch electrical supply to the appliance ON.
- 6.8.14 Ensure that the Main Burner re-ignites when the appliance temperature reduces, (**note:** with the fan disconnected, there may be some delay before the Main Burner re-ignites).

**Table 4 Main Pressure Settings**

	LOW RATE			MEDIUM RATE			HIGH RATE		
	kW	MJ/h	Btu/h	kW	MJ/h	Btu/h	kW	MJ/h	Btu/h
INPUT	21.6	77.6	73,550	23.3	83.62	79,277	25.0	90.0	85,302
OUTPUT	16.1	58.0	55,000	17.6	63.3	60,000	19.1	68.6	65,000
Gas rate cv 1037Btu/ft <sup>3</sup>	2.05m <sup>3</sup> /h (72.62ft <sup>3</sup> /h)			2.21 <sup>3</sup> /h (87.27ft <sup>3</sup> /h)			2.38m <sup>3</sup> /h (84.22ft <sup>3</sup> /h)		
Burner setting pressure (hot)	11.5mbar (4.6 in wg)			13.2mbar (5.3 in wg)			15.5mbar (6.2 in wg)		
Main Injector	BRAY CAT 23/850								

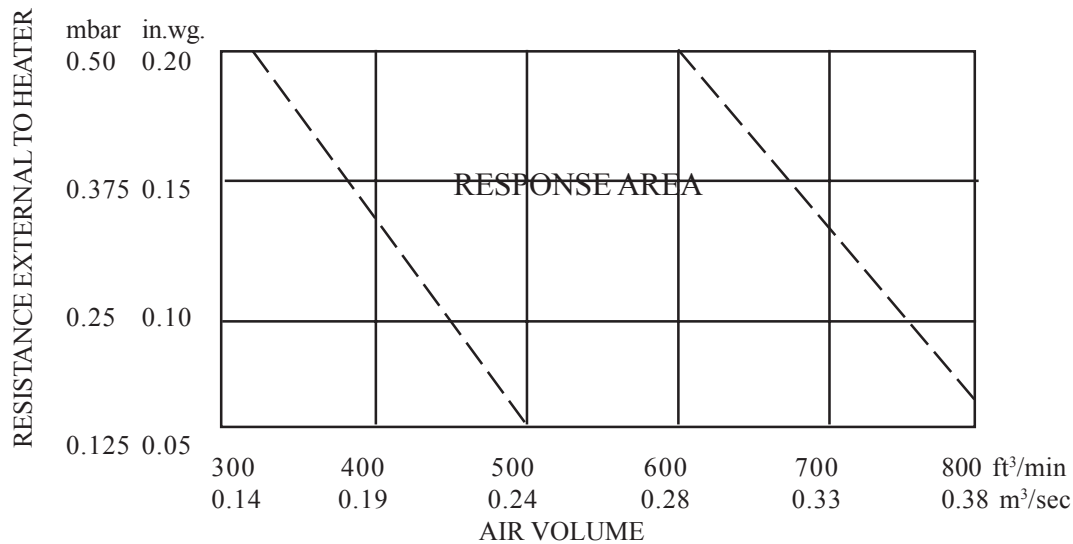

**Table 5**  
**Fan Performance Curve**

**INSTRUCTIONS FOR USERS**

- 1 If the building is unoccupied, ensure that the Instructions for User are left taped to the air heater for the User, and Installation Instructions are left at or near the air heater for use on future service calls.
- 2 If the building is occupied, hand the User Instructions over and ensure the User understands:
  - 7.2.1 How to ignite the Pilot and Main Burners.
  - 7.2.2 How to operate the Thermosta-stat/room thermostat, time and heater ON/OFF switch and summer air circulation switch, and that the Time Control must be reset following a power failure.
  - 7.2.3 How to extinguish the Pilot and Main Burner at the Multifunctional Control, and switch off electrical supply to the heater.
  - 7.2.4 How to remove, clean and re-fit the air filter and at what intervals (i.e. fortnightly, or for new houses, weekly).
  - 7.2.5 How to control the heating system by opening and closing warm air outlets.
  - 7.2.6 How to obtain summer air circulation.
  - 7.2.7 That the air grilles on the heater or heater compartment; grilles and ventilators in the walls, windows or doors of the building must not be obstructed.
  - 7.2.8 Help must be obtained if persistent failure of the pilot burner occurs.
  - 7.2.9 Make sure you understand the instructions for safe use and they have been understood.
  - 7.2.10 After installation and commissioning the Benchmark Checklist is filled in. For IE, it is necessary to complete a 'Declaration of Conformity' to indicate compliance to I.S. 813.
  - 7.2.11 Safe registered engineer. In I.E. servicing work must be carried out by a Registered Gas Installer (RG11).



## 8. MAINTENANCE

**IMPORTANT: Ensure gas and electricity supplies are isolated before commencing any maintenance or replacement of components. After completion of any maintenance, always test for gas soundness and carry out a complete functional test of the appliance in accordance with Commissioning Instructions at Sect 6.1 to 6.8 inclusive.**

### 8.1 ROUTINE MAINTENANCE:

- 8.1.1 Operate the appliance and check for the correct function of the burner and controls.
- 8.1.2 Turn OFF the gas and electrical supplies to the appliance.
- 8.1.3 Remove the air heater front panel.
- 8.1.4 Remove and check the return air filter/cleaner for cleanliness, remove and clean the Air Circulation fan as detailed in para 8.7.
- 8.1.5 Remove the Burner and Controls Assembly as detailed in para 8.2. Inspect and clean the Main Burner and injector as necessary. Examine the Main Burner for cracks, including hairline cracks, exchanging the burner as necessary.
- 8.1.6 Inspect and clear the pilot burner orifice.
- 8.1.7 Clean the heat exchanger flueways by thoroughly brushing from above and below.
- 8.1.8 By viewing through the Fan Aperture, and using a torch or similar, examine the heat exchanger externally for signs of cracks or holes, particularly around welded joints.
- 8.1.9 Using a torch or similar, introduce a light source into the heat exchanger burner aperture and upper access port, and again examine the heat exchanger for signs of cracks or holes, particularly around welded joints, whilst again viewing through the Fan Aperture.
- 8.1.10 Refit the Air Circulation fan, Burner and Controls Assembly, and air filter/air cleaner.
- 8.1.11 Light the appliance and note the main burner flame profile. If the flame profile is affected when the Air Circulation fan switches on, check for any air leaks between the air heater and the base plenum, paying particular attention to heaters with rear draught diverters. Rectify any air leaks before continuing with this procedure.
- 8.1.12 Allow the air heater to operate for approximately 15 minutes to ensure stability, and with the main burner lit, ensure that the operation of Air Circulation fan does not affect the main burner flame profile.

### 8.2 BURNER AND CONTROL ASSEMBLY REMOVAL:

- 8.2.1 Ensure Gas and Electrical supplies are switched OFF
- 8.2.2 Remove appliance lower front door.
- 8.2.3 Disconnect igniter at the piezo unit.
- 8.2.4 Disconnect Multifunctional Control electrical connections.
- 8.2.5 Disconnect the gas supply by breaking the union at the input side of the Multifunctional Control.
- 8.2.6 Whilst supporting the Burner and Control Assembly, remove 2 x Burner assembly fixing screws and withdraw the Burner and Control Assembly
- 8.2.7 Refit Burner and Control Assembly in reverse order, ensuring that the guide plates on the end of each burner arm engage in the slots at the rear of the heat exchanger, and that the spillage baffle above the burner assembly contacts the top of each burner arm.

### 8.3 BURNER AND CONTROL ASSEMBLY CLEANING:

- 8.3.1 Remove Burner and Controls Assembly as detailed in 8.2.
- 8.3.2 Clean burner thoroughly both inside and out with a soft brush. **DO NOT ENLARGE, DISTORT OR DAMAGE BURNER HOLES.**
- 8.3.3 Reassemble in reverse order.

### 8.4 MAIN INJECTORS REMOVAL, CLEANING AND REPLACEMENT:

- 8.4.1 Remove the Burner and Controls assembly as details in 8.2
- 8.4.2 Unscrew the 2 x Main injectors, and 1 x cross lighter injector from their housings.
- 8.4.3 Clean as necessary. **DO NOT ENLARGE, DISTORT OR DAMAGE MAIN INJECTOR HOLES.**
- 8.4.4 If the injectors are to be replaced, ensure that they are correctly marked, referring to the Data Badge for details.
- 8.4.5 Refitment or replacement of injectors in reverse order.

### 8.5 PILOT BURNER, THERMOCOUPLE AND ELECTRODE, REMOVAL AND REPLACEMENT:

- 8.5.1 Remove the Burner and Controls Assembly as detailed in 8.2
- 8.5.2 Disconnect the Igniter lead from the Piezo unit.
- 8.5.3 Disconnect the Thermocouple from the Thermocouple adapter on the Multifunctional Control, taking care to avoid damage to the thermocouple capillary.

- 8.5.4 Release the Pilot Feed Pipe from the Multifunctional Control.
- 8.5.5 Remove 2 x 4mm screws securing the Pilot Burner assembly to the Burner arm, and withdraw the Pilot Burner Assembly.
- 8.5.6 Release the Thermocouple securing nut from the Pilot Burner assembly and withdraw the Thermocouple, taking care to avoid damage to the Thermocouple capillary.
- 8.5.7 Release the Electrode securing nut from the Pilot Burner assembly and withdraw the Electrode.
- 8.5.8 Release the Pilot Feed Pipe securing nut from the Pilot burner assembly and withdraw the Pilot Feed pipe and Pilot Injector from the Pilot Burner assembly, and disconnect the Pilot Injector from the Pilot Feed Pipe hook.
- 8.5.9 Release 2 x 5mm screws securing the Pilot Burner Bracket to the Pilot Mounting bracket, and remove the Pilot Burner Bracket.
- 8.5.10 Refitting or replacement is in reverse order.

**NOTE: When refitting or replacing Thermocouple, tighten only to FINGER TIGHT + 1 FLAT.**

#### 8.6 **MULTIFUNCTIONAL CONTROL REMOVAL:**

- 8.6.1 Remove the Burner and Controls Assembly as detailed in 8.2
- 8.6.2 Disconnect the Thermocouple at the Multifunctional Control including adapter, avoiding damage to the capillary.
- 8.6.3 Disconnect the Pilot gas supply pipe from the Multifunctional control.
- 8.6.4 Disconnect the Multifunctional control input and output supply feeds.
- 8.6.5 Refitting or replacement is in reverse order.

#### 8.7 **PIEZO UNIT REMOVAL:**

- 8.7.1 Disconnect 2 x conductors from Piezo unit.
- 8.7.2 Unscrew the Piezo retaining nut and remove the unit from its mounting bracket.
- 8.7.3 Refitting or replacement is in reverse order.

#### 8.8 **AIR CIRCULATING FAN, REMOVAL AND CLEANING:**

- 8.8.1 Ensure that the electrical supply is isolated.
- 8.8.2 Remove the Air Filter and air heater cabinet doors.
- 8.8.3 Disconnect the Overheat limit device at the terminal block plug situated on the right hand side of the fan chamber floor.
- 8.8.4 Disconnect the 230V connections (L/N/E) from the Fan Assembly.
- 8.8.5 Release the 2 x Fan Assembly securing screws and withdraw the Fan Assembly from the Heater cabinet.
- 8.8.6 Remove and discard the screw securing the Overheat limit device 'P' clip to the side of the Replacement Fan Assembly, and discard the 'P' clip.
- 8.8.7 Remove the screw securing the Overheat limit device terminal block socket to the right hand side of the Replacement Fan Assembly.
- 8.8.8 Refitting or replacement is in reverse order.

#### 8.9 **ELECTRICAL ASSEMBLY REMOVAL:**

- 8.9.1 Ensure that the electrical supply is isolated.
- 8.9.2 Remove the appliance lower and upper doors.
- 8.9.3 Release 2 x 4mm screws securing the Limit switch cover and the withdraw cover.
- 8.9.4 Release 2 x Electrical Assembly cable clamps.

#### **MODAIRFLOW models:**

- 8.9.5 Disconnect the following
  - a. Disconnect 230V connections (L/N/E) from Fan Assembly,
  - b. 230V mains 'L', 'N' and 'E' from connection block terminals '1', '3' and '2' respectively,
  - c. Thermista-stat connections from connection block terminals '4' (+ve) and '5' (-ve),
  - d. Limit switch 'LOAD' and 'COMMON' connections,
  - e. 2 x Airflow sensor connections,

#### **NON-MODAIRFLOW models:**

- 8.9.6 Disconnect the following:
  - a. Disconnect 230V connections (L/N/E) from Fan Assembly,
  - b. 230V mains 'L', 'N' and 'E' from connection block terminals '1' and '3', and earth stud respectively,
  - c. Room thermostat from connection block terminals '5' and '6',

- d. Limit switch 'LOAD' and 'COMMON' connections,
- e. Fan Delay Control 'LOAD', 'COMMON' and 'EARTH' connections,

**Both model types:**

- 8.9.7 Disconnect 2 x TTB connections from the terminal block on the fan compartment diaphragm..
- 8.9.8 Disconnect the Multifunctional control connections.
- 8.9.9 Disconnect the Circulator electrical connections (if fitted).
- 8.9.10 Release 4 x 4mm screws securing the Electrical assembly to the heater cabinet and remove the Electrical assembly, releasing wiring from cable clamps and grommets as required..
- 8.9.11 Refitting or replacement is in reverse order.
- 8.10 **ELECTRONIC MODULE REMOVAL (MODAIRFLOW models only)**
  - 8.10.1 Remove the Electrical assembly as detailed in sect 8.9.
  - 8.10.2 Disconnect the Electronic module from the Electrical assembly.
  - 8.10.3 Release 3 x screws securing the Electronic module to the Electrical assembly and remove the module.
  - 8.10.4 Refitting or replacement is in reverse order.
- 8.11 **TRANSFORMER REMOVAL (MODAIRFLOW models only):**
  - 8.11.1 Remove the Electrical assembly as detailed in sect 8.9.
  - 8.11.2 Disconnect the Transformer from the Electrical assembly terminal block, and fuse from the Earth stud.
  - 8.11.3 Release 2 x screws and nuts securing the Transformer to the Electrical assembly, and remove the Transformer.
  - 8.11.4 Refitting or replacement is in reverse order.
- 8.12 **TIME CONTROL REMOVAL:**
  - 8.12.1 Ensure that the electrical supply is isolated.
  - 8.12.2 Release the securing screw situated on the lower face of the Time Control and remove by partially withdrawing the bottom of the Time Control and then lifting upwards.
  - 8.12.3 Disconnect the Time Control electrical connections from the integral terminal strip.
  - 8.12.4 Refitting or replacement is in reverse order.
  - 8.12.5 Set the Time Control to the required ON and OFF times.
  - 8.12.6 Set the Time Control to correct time.
- 8.13 **FAN DELAY CONTROL, LIMIT SWITCH AND AIRFLOW SENSOR REMOVAL:**  
**NOTE: Airflow Sensor applies to MODAIRFLOW models only, whilst Fan Delay Control applies solely to non-MODAIRFLOW models.**
  - 8.13.1 Ensure that the electrical supply is isolated.
  - 8.13.2 Remove the appliance lower and upper doors.
  - 8.13.3 Release 2 x 4mm screws securing the Limit switch cover and withdraw the cover.
  - 8.13.4 Disconnect the required control/switch.
  - 8.13.5 Release 2 x securing screws and remove required control/switch.
  - 8.13.6 Refitting or replacement is in reverse order.
- 8.14 **SPILLAGE MONITORING DEVICE (TTB) REMOVAL:**
  - 8.14.1 Ensure that the electrical supply is isolated.
  - 8.14.2 Remove the appliance lower and upper doors.
  - 8.14.3 Remove the Air Circulation fan as detailed in para 8.8.
  - 8.14.4 Cover the aperture to the heat exchanger in the top shelf to prevent objects falling into the heat exchanger.
  - 8.14.5 Release and remove the 6 x screws securing the fan compartment rear plate, and withdraw the rear plate.
  - 8.14.6 Release and remove the 6 x screws securing the draught diverter access panel, and withdraw the access panel.
  - 8.14.7 Whilst holding the TTB Access Panel, release the 2 x securing screws and withdraw the TTB access panel.
  - 8.14.8 Release the screw securing the TTB bracket assembly, and withdraw the bracket assembly.
  - 8.14.9 Release the 2 x M4 screws securing the TTB Bracket to the TTB Assembly and withdraw the Bracket
  - 8.14.10 Disconnect the TTB from its conductors.



8.14.10 Disconnect the TTB from its conductors.

8.14.11 Refitting or replacement is in reverse order.

8.15 **HEAT EXCHANGER ACCESS:**

8.15.1 Ensure that the electrical supply is isolated.

8.15.2 Remove the appliance lower and upper doors.

8.15.3 Remove the Electrical assembly as detailed in sect 8.9.

8.15.4 Release the 6 x screws securing the Heat Exchanger Access panel and remove the access panel cap and gasket.

8.15.5 Release the 4 x screws securing each end cap and remove the end caps and gaskets.

8.15.6 Remove the Heat Exchanger baffles.

8.15.7 Reassembly is in reverse order.

**NOTE: When reassembling, ensure that the baffle is pushed fully home and that the access cap is fully sealed. In the event of heat exchanger replacement being necessary, contact Johnson and Starley Service Department.**

## 9. DEFECT DIAGNOSIS

9.1 **IMPORTANT:** If an electrical defect occurs after installation of the appliance; preliminary earth continuity, polarity, and resistance to earth checks should be carried out with a multimeter. On completion of any maintenance/fault-finding task that has required the breaking and remaking of electrical connections, then checks of continuity, polarity, and resistance to earth must be repeated.

### 9.2 WARNINGS:

9.2.1 When purging or checking gas supplies, ensure that the ventilation to the room or cupboard is adequate, and all naked lights are extinguished.

9.2.2 **MODAIRFLOW models:** Before commencing defect diagnosis, ensure that the Thermista-stat is set to maximum, the mains supply is 'ON' and the Time Control is at an 'ON' position.

9.2.3 Care is to be taken during the replacement and handling of electronic assemblies (i.e. electronic panel, airflow sensor or Thermista-stat), it is not practical to rectify defects on these assemblies, except at the manufacturer, and any attempt to do so may render the guarantee or factory replacement arrangement invalid.

SYMPTOM	POSSIBLE CAUSE	REMEDY
a. Pilot will not light.	i. No gas supply to heater.	Check for gas at inlet pressure test point on Multifunctional Control.
	ii. Gas supply pipe not purged.	Purge gas supply pipe in accordance with BS 6891.
	iii. Pilot orifice restricted.	Clear pilot orifice or replace pilot injector.
	iv. Piezo system faulty.	Check igniter, lead, and electrode.
	v. Excessive gas supply pressure.	Check that mains gas pressure is 20mbar, and reduce if necessary.
b. Pilot lights but goes out on releasing START button during initial light-up, or after normal operation.	i. Connection between thermocouple and Multifunctional Control not secure.	Check connection is secure.
	ii. Faulty power unit on Multifunctional Control.	Replace Multifunctional Control.
	iii. Faulty thermocouple.	Replace Thermocouple.
c. Main burner lights but fan fails to run after approx. 3 min.	i. Loose electrical connection Fan Delay Control.	Check connections.
	ii. Fan control set incorrectly.	Check for correct settings.
	iii. Faulty fan assembly.	Replace, taking care not to damage impeller.
	iv. Faulty Fan Delay Control.	Replace
d. Main burner operating intermittently with fan running.	i. Gas rate or burner pressure setting high.	Check gas rate and burner pressure setting.
	ii. Temperature rise excessive.	Adjust fan speed or gas rate accordingly.
	iii. Air filter or return air path restricted.	Check filter is clean and air path is clear.
	iv. Excessive number of outlets closed.	Open additional outlets.
	v. Spillage of flue gases.	Carry out spillage test and rectify.
	vi. Spillage monitor device (TTB) faulty.	Replace Spillage device (TTB)
e. Main burner operating with intermittent fan operation.	i. Gas rate or burner pressure setting too low.	Check gas rate and burner pressure setting.
	ii. Fan Delay Control set incorrectly.	Check for correct settings.

f.	Fan runs for excessive period or operates intermittently after main burner shuts down.	i. Fan Delay Control set incorrectly.	Check for correct settings.
g.	Noisy operation.	i. Gas pressure too high. ii. Noisy fan motor. iii. Fan speed setting too high.	Check burner pressure setting. Replace fan assembly. Adjust fan speed.
<b>MODAIRFLOW models:</b>			
h.	Incorrect operation of fan or main burner.	Fault related to Modairflow Control system (refer to pages 16-20)	Consult diagnostic chart and follow recommended procedure.
<b>Non-MODAIRFLOW models:</b>			
j.	Pilot alight but main burner not igniting.	i. Mains electrical supply not connected to heater. ii. Controls not demanding heat iii. 3A fuse failed. iv. Loose connection to room thermostat, Limit Switch, Multifunctional Control lead, Time Control, or transformer. v. Transformer open circuit. vi. Multifunctional Control faulty. vii. Limit Switch faulty. viii. Room thermostat or external wiring faulty. ix. TTB faulty	Check mains supply. Check that time control and room thermostat are operating correctly. Replace. If failure occurs again, check wiring for short circuits. Check connections. Check with test meter and replace transformer (Modairflow) or electrical assembly (non-Modairflow). Replace Multifunctional Control. Short circuit control and replace if necessary. Fit temporary loop in heater thermostat socket. If heater ignites, external circuit or room thermostat is faulty. Check TTB and wiring for open circuit

## 10. FAULT FINDING

### MODAIRFLOW FAULT FINDING

#### MAIN BURNER ON, BUT FAN NOT RUNNING

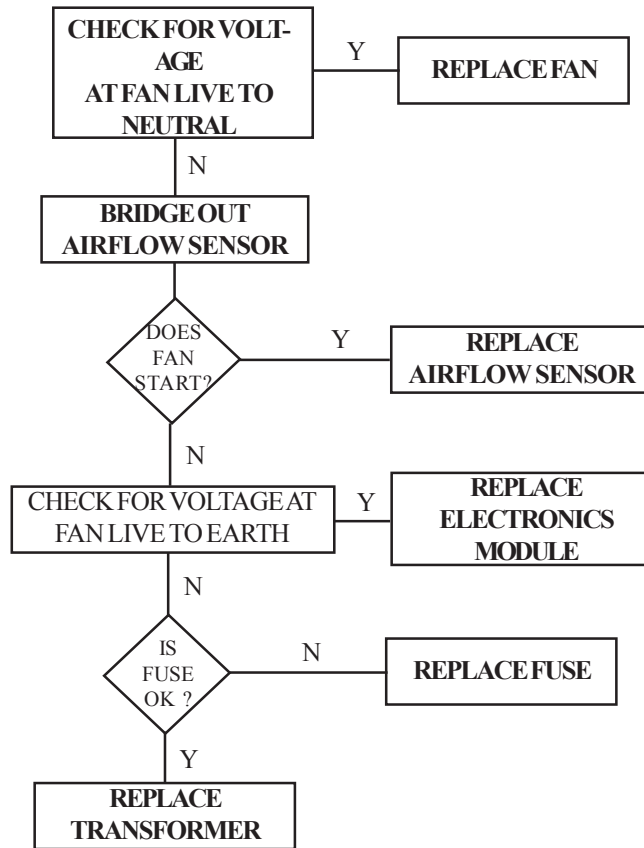

#### MAIN BURNER NOT CYCLING (ROOM TEMPERATURE TOO HIGH)

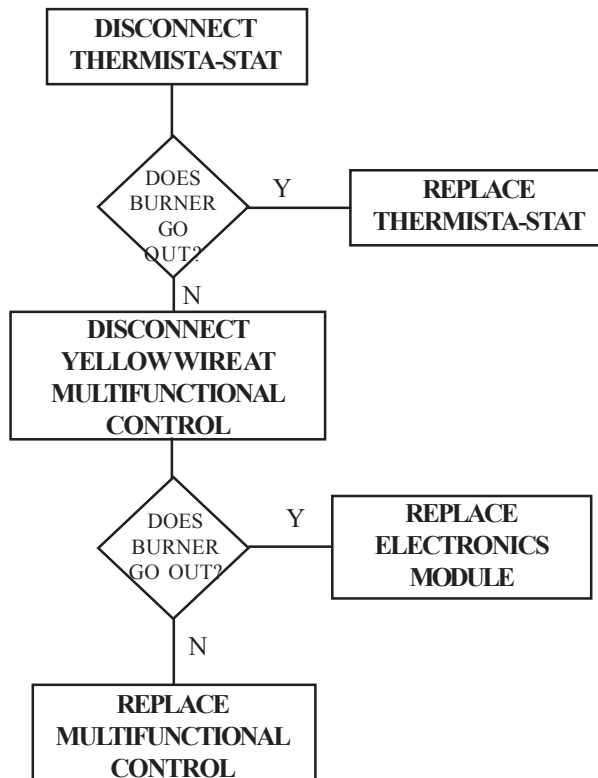

## MAIN BURNER NOT OPERATING

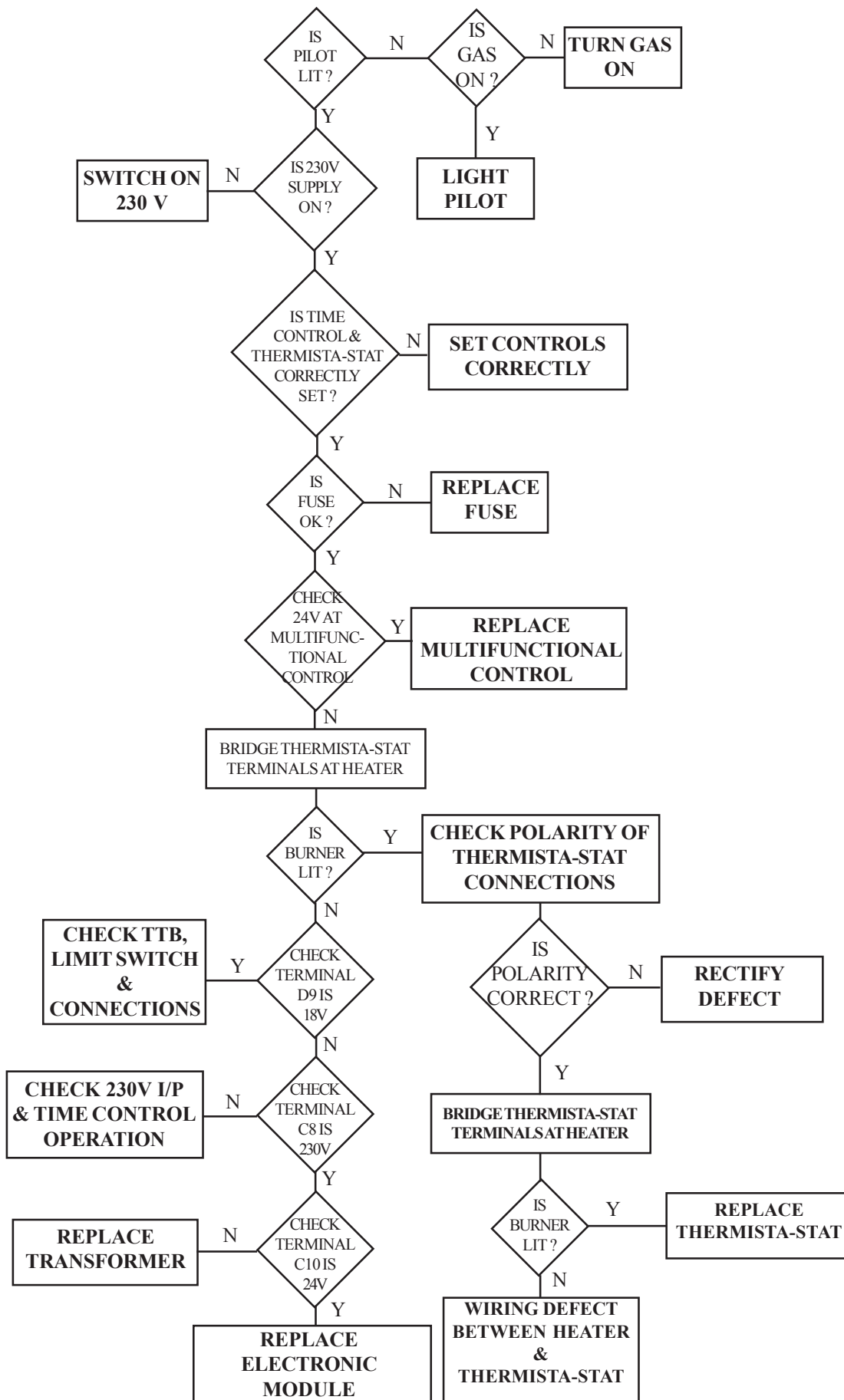

**FAN OPERATES, BUT BURNER CYCLES BEFORE REQUIRED TEMPERATURE IS REACHED**

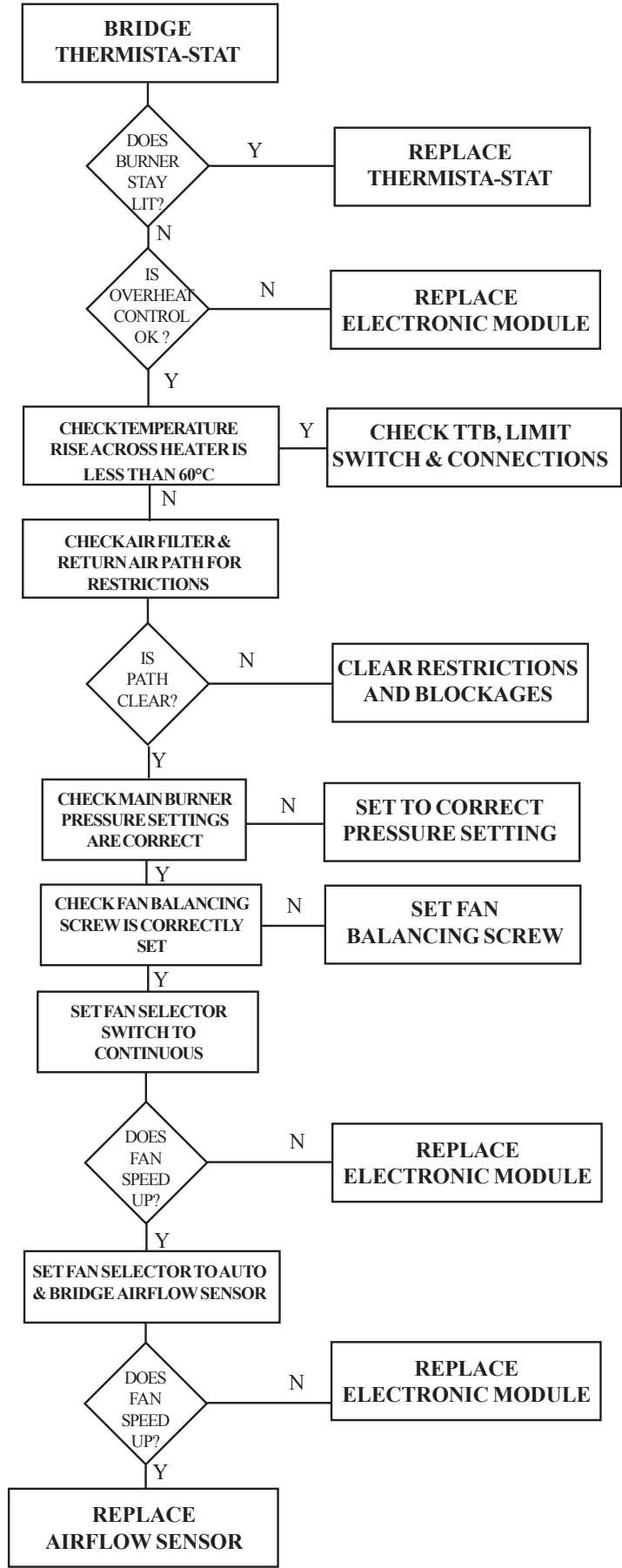

**MAIN BURNER ONLY FIRES FOR SHORT PERIODS**

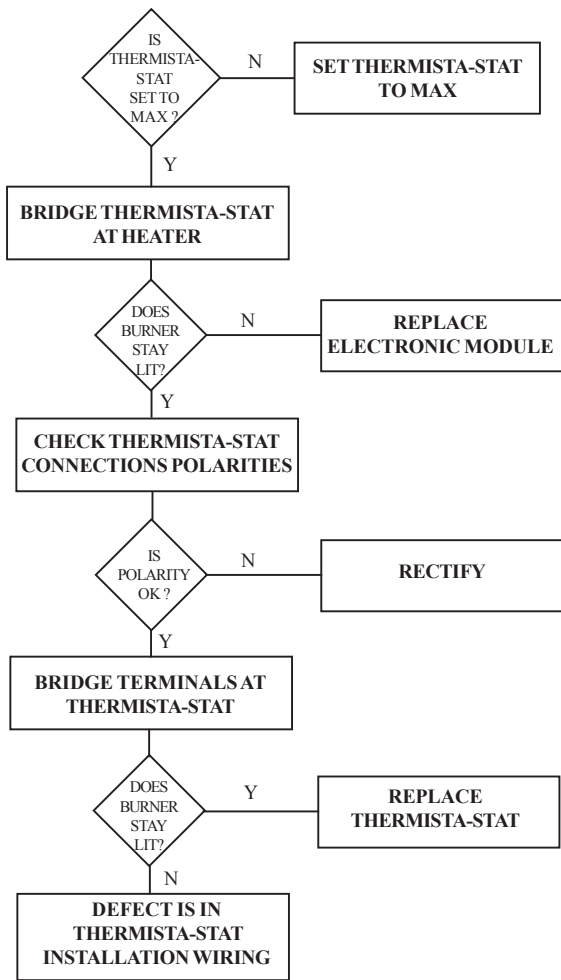

**FAN CONTINUES TO RUN AFTER HEATING IS TURNED OFF**

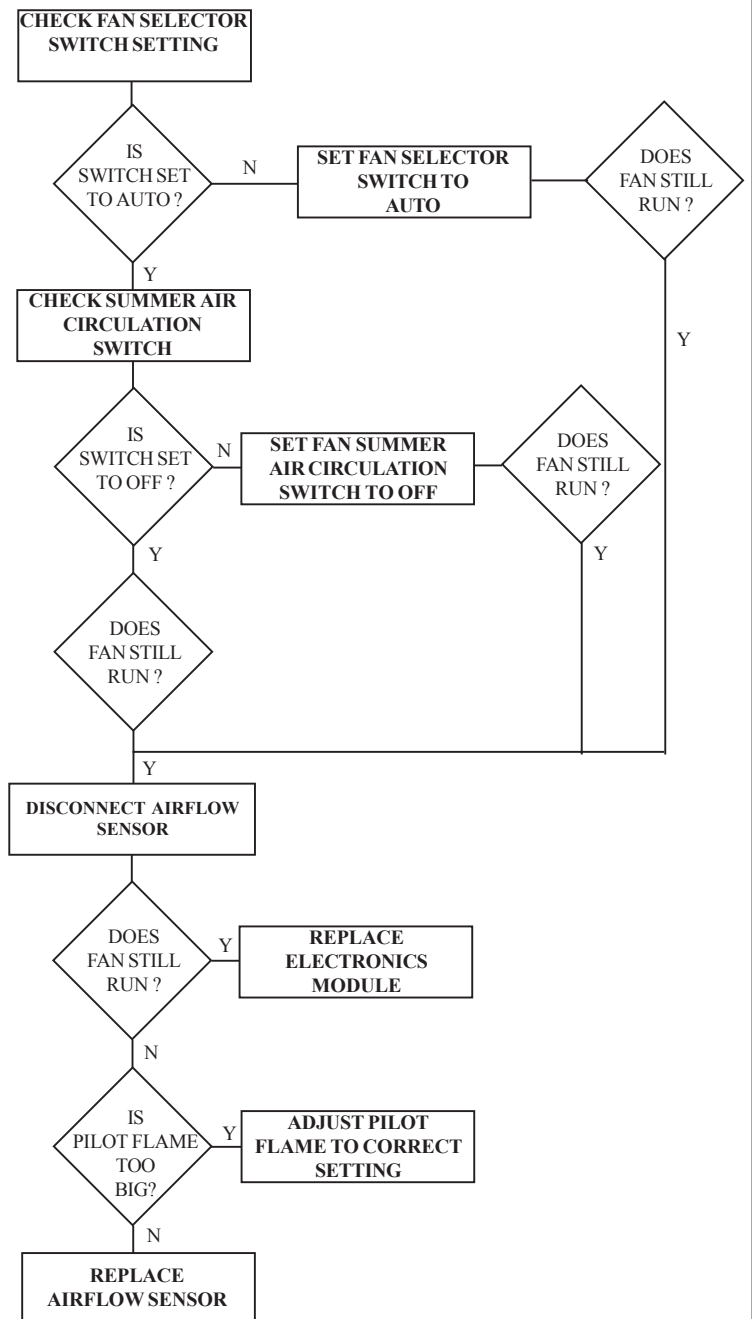

# 11. WIRING DIAGRAMS

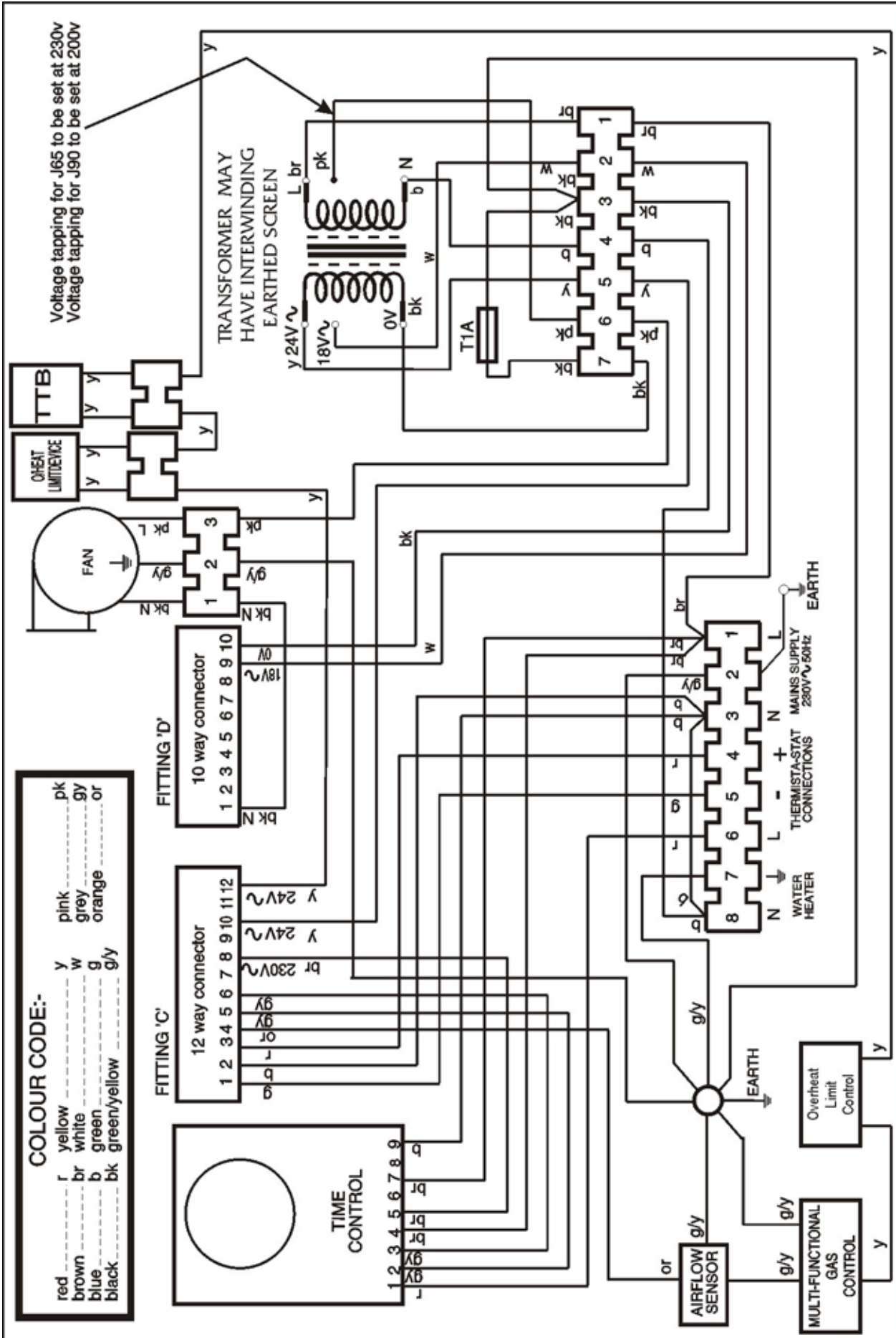

Issue - 07

Fig 5a. MODAIRFLOW CIRCUIT DIAGRAM



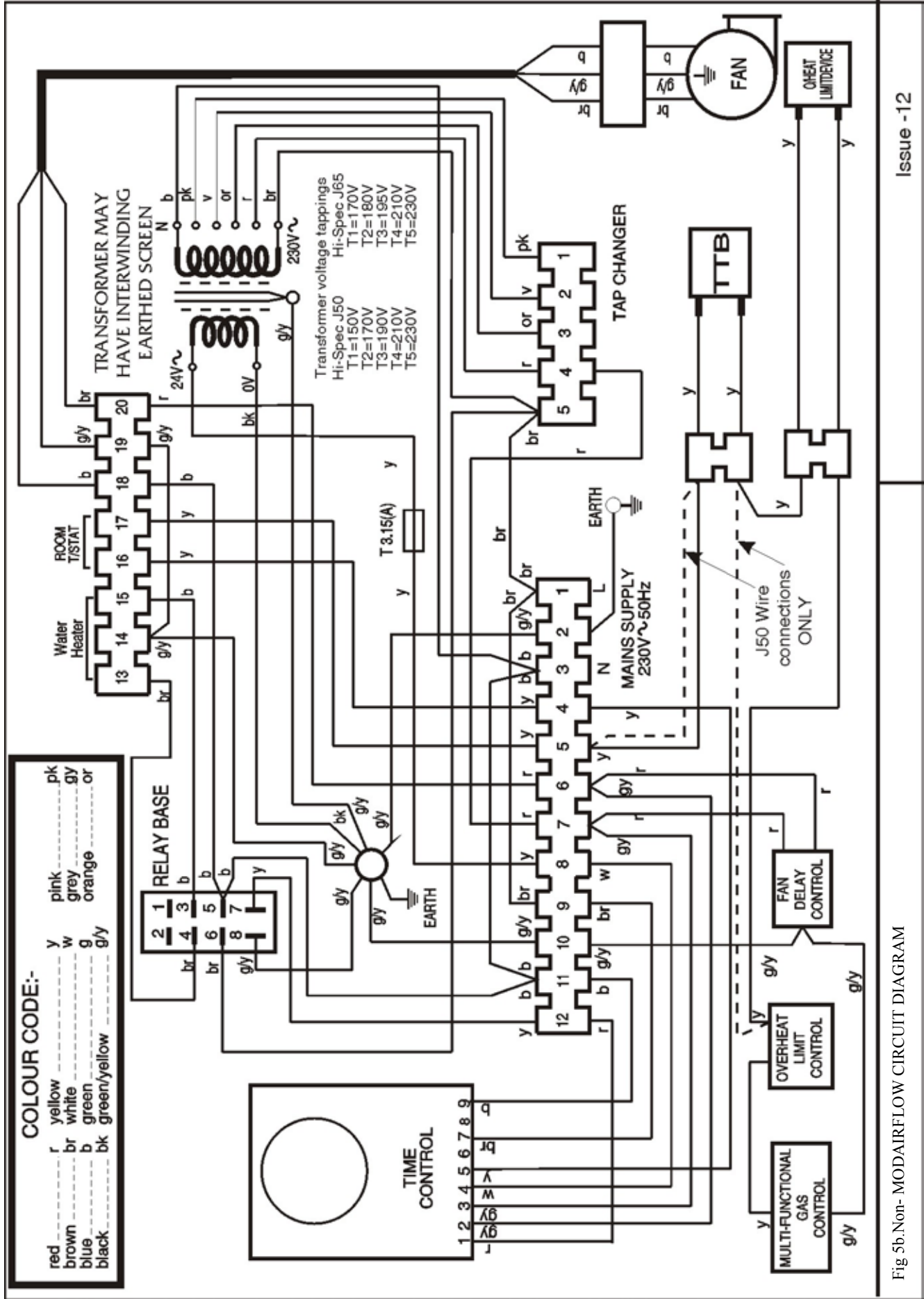
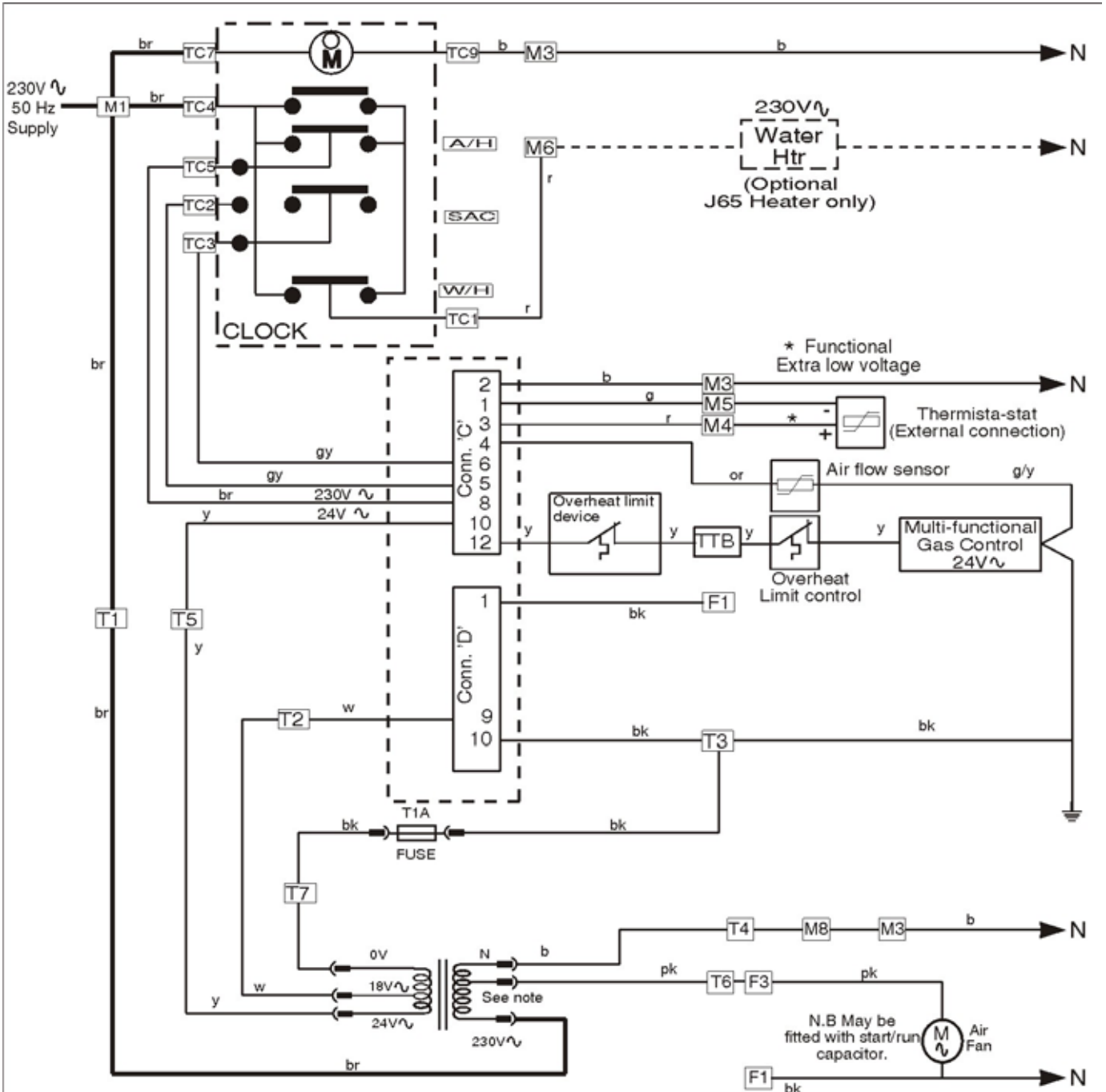

Fig 5b.Non- MODAIRFLOW CIRCUIT DIAGRAM

## 12. FUNCTIONAL DIAGRAMS



Wire colour code where indicated	
pink	pk
red	r
blue	b
black	bk
brown	br
white	w
grey	gy
orange	or
green	g
yellow	y
green/yellow	g/y

### NOTE:-

Transformer tapping for Hi-Spec J65  
TO BE SET AT 230V ~  
Transformer tapping for Hi-Spec J90  
TO BE SET AT 200V ~

F = Fan terminal block  
T = Transformer terminal block  
M = Main terminal block  
TC = Time control connections

Fig 6a. Non-MODAIRFLOW FUNCTIONAL DIAGRAM

Issue 02

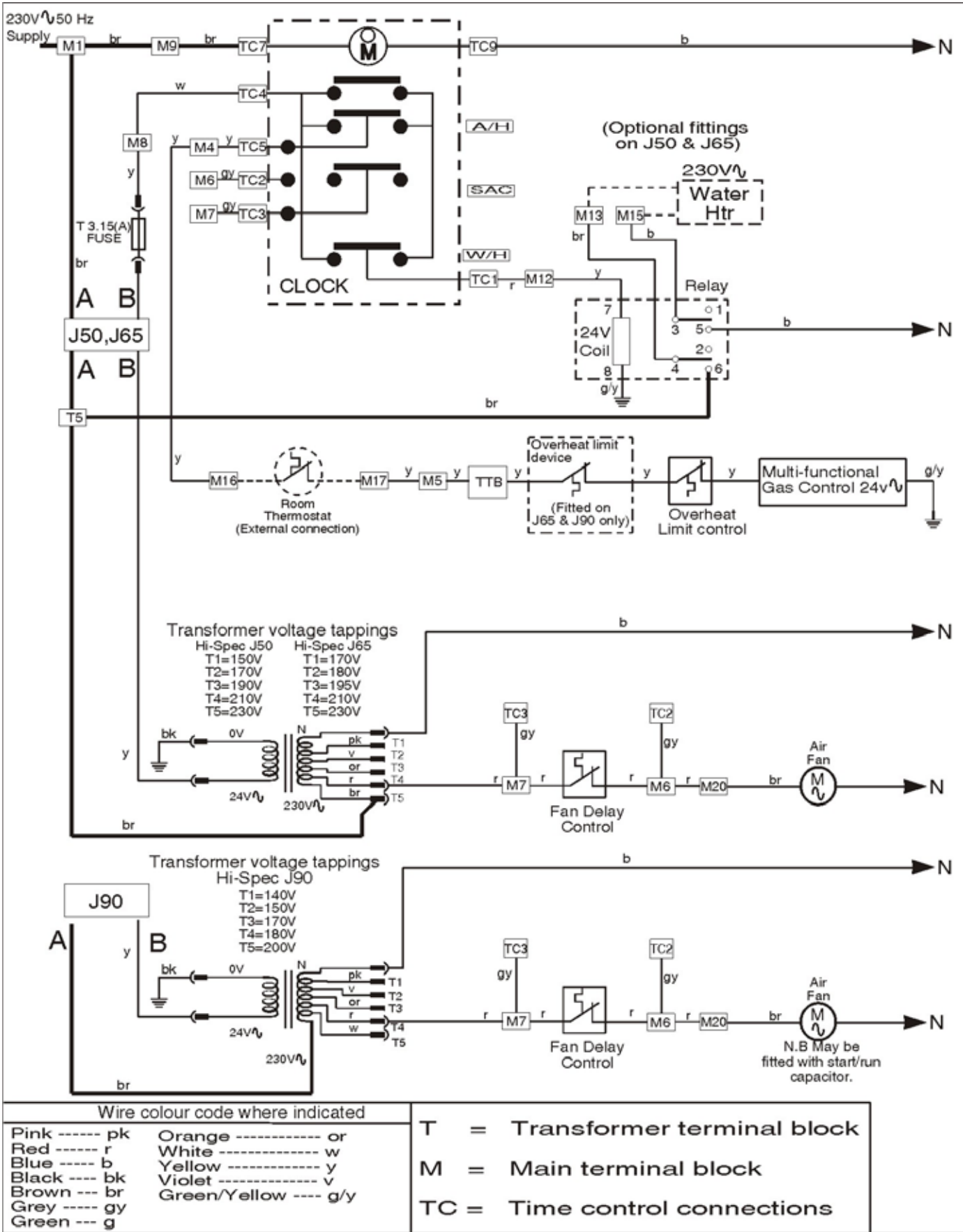
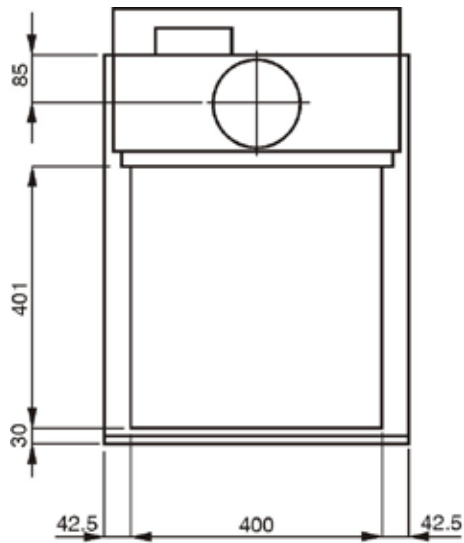

Fig 6b. MODAIRFLOW FUNCTIONAL DIAGRAM

Issue - 04

## 13. DIMENSIONS



PLAN VIEW

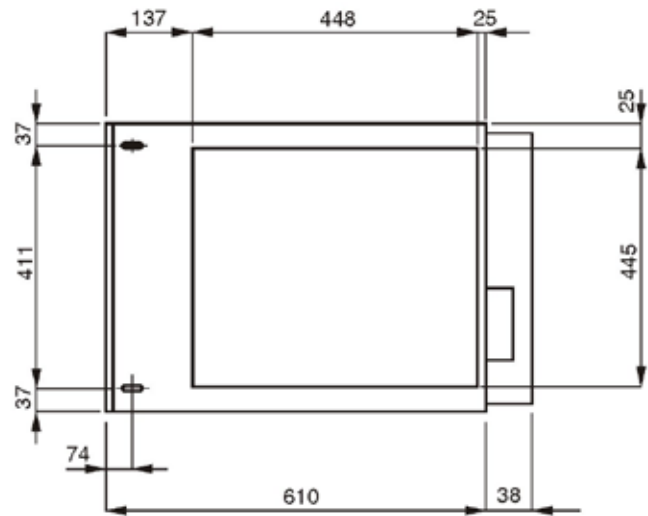

BASE VIEW

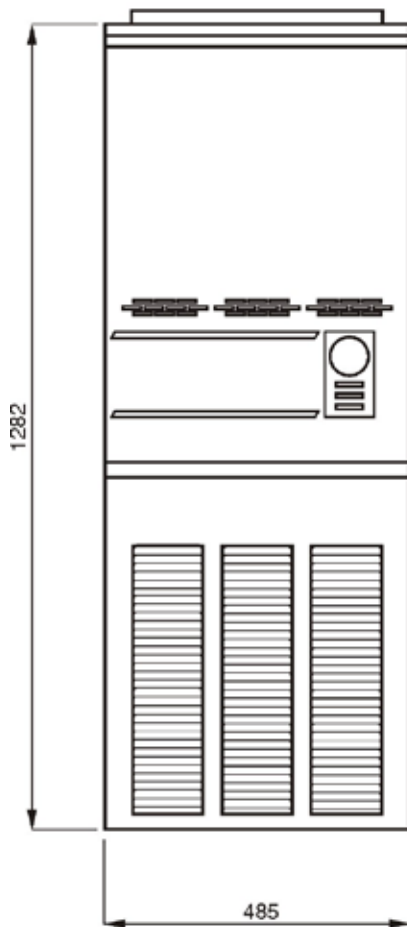

KNOCKOUTS FOR  
WATER CONNECTION  
(BOTH SIDES)

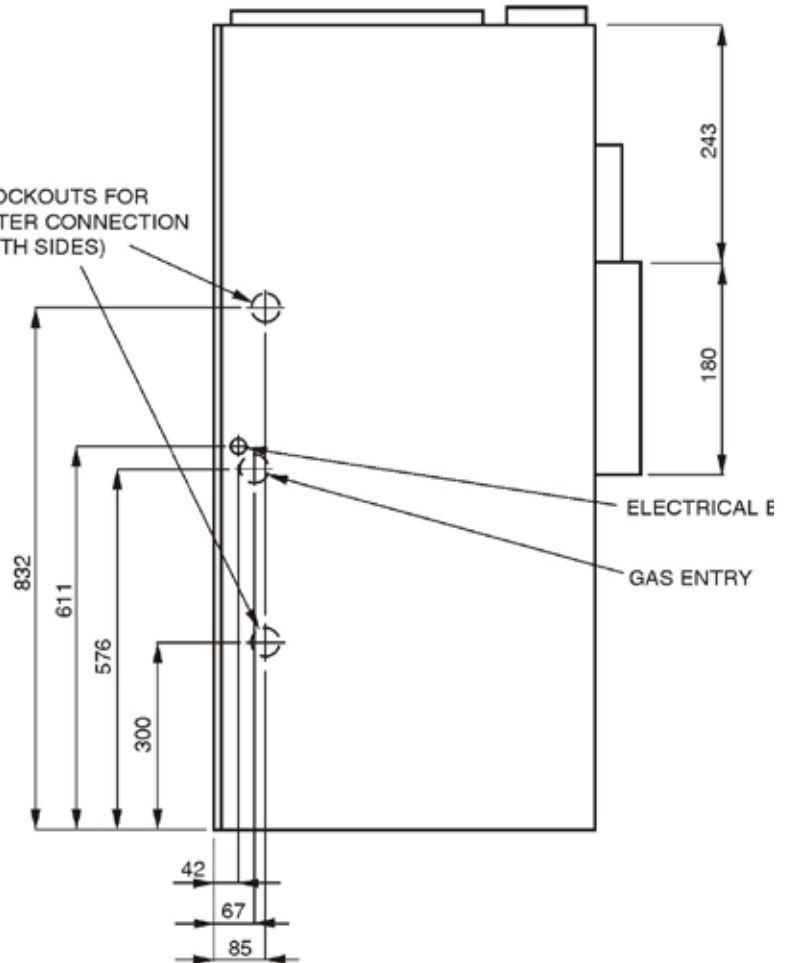

Fig 7. HI-SPEC J65 DIMENSIONS



## 15. SHORT LIST OF SPARES

ITEM No	G.C No	MAKER'S No	DESCRIPTION	QTY
1	245-176	J650-0525000	Fan assembly	1
2	E02-430	J652-0182000	Filter tray assembly	1
3	244 985	CL3S	Time control CL3	1
4	244 986	1000-0000040	Time control cover	1
5	384739	BOS00105	Limit Switch	1
6	393412	BOS01301	Honeywell L4069C Multifunctional Control Honeywell V8600C	1
7	232 903	BOS02061	Sealing ring (for item 6)	2
8	244 880	BOS02397/4	Pilot assembly	1
9	392 935	1000-0701260	Pilot Injector	1
10	E02-431	1000-0705390	Pilot Feed Pipe	1
11	386-820	1000-0703870	Thermocouple	1
12	386 775	BOS01970	Electrode	1
13	397 819	BOS02394	Electrode lead	1
14	244 898	BOS02406	Electrode Nut	1
15	E02-554	J652-0391000	Spillage switch (TTB) Assembly	1
16	E02-555	J652-0700000	Burner and Controls Assembly	1
17	E02-432	1000-0705290	Burner and Cross Lighter Assembly	1
18	398 353	208S711	Main Injector Bray Cat 23/850	2
19	E02-422	1000-0705340	Cross Lighting Injector (Bray)	1
	E02-423	1000-0705310	Cross Lighting Injector (Stereomatic)	1
20	E02-556	J652-0350005	Heat Exchanger exchange kit	1
21	395 945	1000-0700570	Piezo Unit	1
22	244 971	B300-0706000	Igniter Bracket	1
23	230-394	BOS 00836	Gasket (for heat exchanger cap)	2
24	E02-557	J652-0161000	Lower Compartment Door	1

or

### MODAIRFLOW MODELS

25	E02-559	J652-0156000	Fan Compartment Door	1
26	245 174	J650-0530005	Control Panel with Transformer	1
27	245 137	J650-0519000	Wiring Harness	1
28	245 178	R010	Electronics Module	1
29	245 170	1000-0505690	Airflow Sensor	1
30	E02 428	1000-0514230	Fuse 1A, (T)	2
31	386 475	BOS01242	Thermista-stat	1
32	E02-433	1000-0516875	Transformer	1

### NON-MODAIRFLOW MODELS

33	E02-560	J652-0157000	Fan Compartment Door	
34	245 142	1000-0501910	Control Panel	1
35	245 094	J650-0520005	Wiring Harness	1
36	385 159	BOS00104	Fan Delay Control Honeywell L4068C	1
37	244 938	1000-0513820	Fuse 3.15A, (T)	1
38	245 322	1000-0500910	Relay 24V	1
39	396 634	1000-0503730	Overheat Thermista-stat	1
40	E05 247	EC65-90H	Cleanflow Electronic Air Cleaner	1
41	E05 248	A0354X0357	Cleanflow Pad Replacement	2

# 16. EXPLODED DIAGRAM

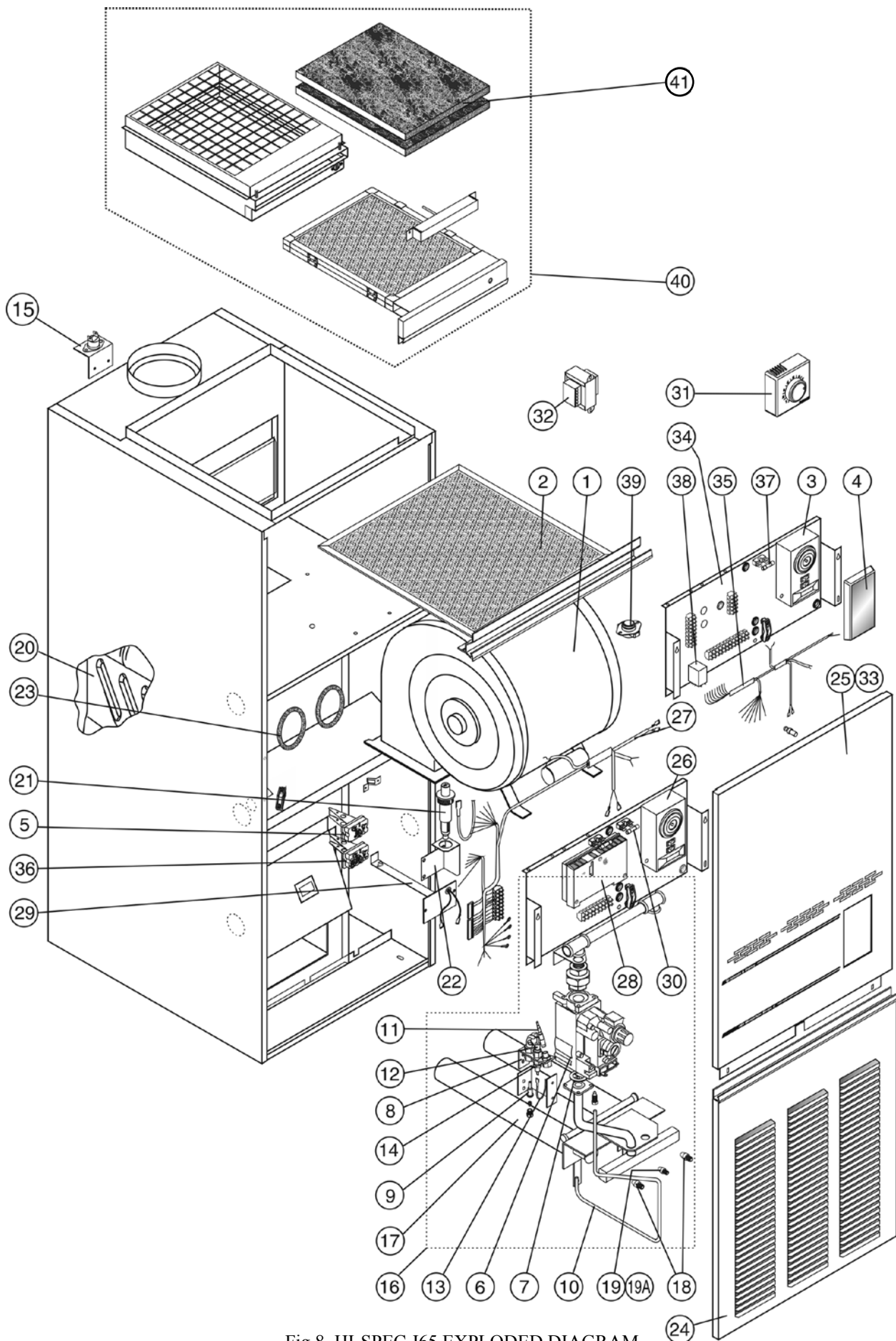

Fig 8. HI-SPEC J65 EXPLODED DIAGRAM

## 17. INFORMATION & ANCILLARIES

Warm Air Heating fully complies with

**PART L OF THE BUILDING REGULATIONS**  
by following the guidance in the **British Standard BS 5864**  
and the **HEATING COMPLIANCE GUIDE**

For further information contact

Johnson & Starley Ltd on Telephone: 01604 762881



HI-SPEC J65 ANCILLARIES		
ITEMS	DESCRIPTION	PART No.
1	Base Tray	BT 65
2	Base Duct	WB65-90
3	Plenum Adapter Kit	PAK65
4	Return Air Kit	RAK65
5	Cleanflow Electronic Air Cleaner	CF 90H
6	Replacement Pads	A0354X0357





# Code Of Practice

For the installation, commissioning and servicing of domestic heating and hot water products

Benchmark places responsibilities on both manufacturers and installers.\* The purpose is to ensure that customers\*\* are provided with the correct equipment for their needs, that it is installed, commissioned and serviced in accordance with the manufacturer's instructions by competent persons and that it meets the requirements of the appropriate Building Regulations. Installers are required to carry out work in accordance with the following:

## Standards of Work

- Be competent and qualified to undertake the work required.
- Install, commission, service and use products in accordance with the manufacturer's instructions provided.
- Ensure that where there is responsibility for design work, the installation is correctly sized and fit for purpose.
- Meet the requirements of the appropriate Building Regulations. Where this involves notifiable work be a member of a Competent Persons Scheme or confirm that the customer has notified Local Authority Building Control (LABC), prior to work commencing.
- Complete all relevant sections of the Benchmark Checklist/Service Record when carrying out commissioning or servicing of a product or system.
- Ensure that the product or system is left in a safe condition and, whenever possible, in good working order.
- Highlight to the customer any remedial or improvement work identified during the course of commissioning or servicing work.
- Refer to the manufacturer's helpline where assistance is needed.
- Report product faults and concerns to the manufacturer in a timely manner.

## Customer Service

- Show the customer any identity card that is relevant to the work being carried out prior to commencement or on request.
- Give a full and clear explanation/demonstration of the product or system and its operation to the customer.
- Hand over the manufacturer's instructions, including the Benchmark Checklist, to the customer on completion of an installation.
- Obtain the customer's signature, on the Benchmark Checklist, to confirm satisfactory demonstration and receipt of manufacturer's instructions.
- Advise the customer that regular product servicing is needed, in line with manufacturers' recommendations, to ensure that safety and efficiency is maintained.
- Respond promptly to calls from a customer following completion of work, providing advice and assistance by phone and, if necessary, visiting the customer.
- Rectify any installation problems at no cost to the customer during the installer's guarantee period.



\*The use of the word "installer" is not limited to installation itself and covers those carrying out installation, commissioning and/or servicing of heating and hot water products, or the use of supporting products (such as water treatment or test equipment).

\*\*Customer includes householders, landlords and tenants.

# WARM AIR HEATER AND CIRCULATOR COMMISSIONING CHECKLIST

This Commissioning Checklist is to be completed in full by the competent person who commissioned the warm air unit and associated equipment as a means of demonstrating compliance with the appropriate Building Regulations and then handed to the customer to keep for future reference.

Failure to install and commission this equipment to the manufacturer's instructions may invalidate the warranty but does not affect statutory rights.

Customer name:										Telephone number:									
Address:																			
Warm Air Unit Make and Model																			
Warm Air Unit Serial Number																			
Commissioned by (PRINT NAME):										Gas Safe Reg. No.									
Company name:										Telephone number:									
Company address:																			
										Commissioning date:									
<b>To be completed by the customer on receipt of a Building Regulations Compliance Certificate*:</b>																			
Building Regulations Notification Number (if applicable)																			
<b>CONTROLS</b> (tick the appropriate boxes if applicable)																			
Time and temperature control to heating										Room thermostat and programmer/timer					Programmable Roomstat				
										Load/weather compensation					Optimum start control				
Time and temperature control to hot water										Cylinder thermostat and programmer/timer					Warm air unit				
Heating zone valves										Fitted					Not required				
Hot water zone valves										Fitted					Not required				
Thermostatic radiator valves										Fitted					Not required				
Automatic bypass system										Fitted					Not required				
Warm Air Unit Interlock										Yes		No		If YES		Volume:		Litres	
<b>FOR WARM AIR HEATERS ONLY</b>																			
Has the system been balanced in accordance with the heater manufacture's instructions?										Yes		No							
Was an anemometer used?										Yes		No							
Have balancing dampers been fitted?										Yes		No							
<b>FOR WARM AIR HEATING: MEASURE AND RECORD</b>																			
Burner operating pressure															mbar				
Heat input															kW				
Temperature difference between return air inlet and nearest outlet															°C				
<b>FOR HOT WATER GENERATORS: measure and record</b>																			
Burner operating pressure															mbar				
Heat input															kW				
Water flow temperature															°C				
<b>ALL INSTALLATIONS</b>																			
The heating and hot water system complies with the appropriate Building Regulations										Yes									
The system and associated products have been installed and commissioned in accordance with the manufacturer's instructions										Yes									
The efficient operation of system and its controls have been demonstrated to and understood by the customer										Yes									
The manufacturer's literature, including Benchmark Checklist and Service Record, has been explained and left with the customer										Yes									
Commissioning Engineer's Signature																			
Customer's Signature																			
(To confirm demonstration of equipment and receipt of appliance instructions)																			

\*All installations in England and Wales must be notified to Local Authority Building Control (LABC) either directly or through a Competent Persons Scheme. A Building Regulations Compliance Certificate will then be issued to the customer.



# SERVICE RECORD

It is recommended that your heating system is serviced regularly and that the appropriate Service Interval Record is completed.

## Service Provider

Before completing the appropriate Service Record below, please ensure you have carried out the service as described in the manufacturer's instructions. Always use the manufacturer's specified spare part when replacing controls.

<b>SERVICE 01</b>		Date:		<b>SERVICE 02</b>		Date:	
Engineer name:				Engineer name:			
Company name:				Company name:			
Telephone No:				Telephone No:			
Operative ID No:				Operative ID No:			
Comments:				Comments:			
.....				.....			
.....				.....			
.....				.....			
Signature				Signature			
<b>SERVICE 03</b>		Date:		<b>SERVICE 04</b>		Date:	
Engineer name:				Engineer name:			
Company name:				Company name:			
Telephone No:				Telephone No:			
Operative ID No:				Operative ID No:			
Comments:				Comments:			
.....				.....			
.....				.....			
.....				.....			
Signature				Signature			
<b>SERVICE 05</b>		Date:		<b>SERVICE 06</b>		Date:	
Engineer name:				Engineer name:			
Company name:				Company name:			
Telephone No:				Telephone No:			
Operative ID No:				Operative ID No:			
Comments:				Comments:			
.....				.....			
.....				.....			
.....				.....			
Signature				Signature			
<b>SERVICE 07</b>		Date:		<b>SERVICE 08</b>		Date:	
Engineer name:				Engineer name:			
Company name:				Company name:			
Telephone No:				Telephone No:			
Operative ID No:				Operative ID No:			
Comments:				Comments:			
.....				.....			
.....				.....			
.....				.....			
Signature				Signature			
<b>SERVICE 09</b>		Date:		<b>SERVICE 10</b>		Date:	
Engineer name:				Engineer name:			
Company name:				Company name:			
Telephone No:				Telephone No:			
Operative ID No:				Operative ID No:			
Comments:				Comments:			
.....				.....			
.....				.....			
.....				.....			
Signature				Signature			



sustainable solutions  
**under one roof**

**Johnson & Starley Ltd**

Rhosili Road, Brackmills,  
Northampton NN4 7LZ

[sales@johnsonandstarley.co.uk](mailto:sales@johnsonandstarley.co.uk)

[marketing@johnsonandstarley.co.uk](mailto:marketing@johnsonandstarley.co.uk)

**Reception/Customer Service**

01604 762881

**Fax**

01604 767408

