



sustainable solutions **under one roof**

HEATING / HOT WATER / VENTILATION

Publication No. ZZ 0815-10
October 2016

HI-SPEC J40

Warm Air Heater

with System E-T &
Conventional Control



INSTALLATION, COMMISSIONING
& SERVICING INSTRUCTIONS

Hi-Spec J40 - G.C. No. 42-451-09

These instructions are to be left with the User



www.johnsonandstarley.co.uk

CONTENTS

The Benchmark Scheme	2	14 Users Instructions	16
1 Features	3	15 Servicing & Maintenance	17
2 General Description	3	<i>Routine Maintenance</i>	
3 Building Standards & Regulations	4	<i>Burner & Control Assembly Removal</i>	
4 Safety & Gas Information	4	<i>Burner & Control Assembly Cleaning</i>	
<i>General Safety Information</i>		<i>Main Ignition Removal, Cleaning & Replacement</i>	
<i>Gas Categories</i>		<i>Pilot Burner, Thermocouple & Electrode Removal & Replacement</i>	
<i>Gas Supply</i>		<i>Multi Functional Control Removal</i>	
5 Technical Data	5	<i>Piezo Unit Removal</i>	
6 Heater Compartment Clearances	5	<i>Air Circulation Fan Removal & Cleaning</i>	
7 Ventilation & Combustion Air	6	<i>Electrical Assembly Removal</i>	
8 Duct System	6	<i>Electrical Module Removal</i>	
<i>Return Air</i>		<i>Transformer Removal</i>	
<i>Warm Air Delivered</i>		<i>Time Control & Switch Removal</i>	
9 Flue Instructions	7	<i>Fan Delay Control/Limit Switch Removal</i>	
<i>Flue Installation</i>		<i>Spillage Monitoring Device (TTB) Removal</i>	
<i>Plume Terminal Positions</i>		<i>Heat Exchanger Access</i>	
<i>Flue Terminal Positions</i>		16 Defect Diagnosis	19
<i>Resistance Factors</i>		17 Dimensions	21
<i>Worked Calculation Factor</i>		18 Fault Finding Flowcharts	22
<i>Equivalent Flue Lengths</i>		19 Functional Diagrams	24
10 Electrical	12	20 Circuit Diagram	26
<i>Mains Supply</i>		21 Short List of Spares	28
<i>Thermista-stat & It's Location</i>		22 Exploded Diagram	29
11 Gas	12	23 Benchmark Checklist and Service Record	30
12 Fitting Instructions	12		
13 Commissioning	13		
<i>Preparation</i>			
<i>System Balancing</i>			
<i>Lighting Ignition & Main Burner</i>			
<i>Main Burner Pressure Test</i>			
<i>Extinguishing of Pilot & Mains Burners</i>			
<i>Temperature Rise Checks</i>			
<i>Automatic Controls Check</i>			
<i>Safety Check</i>			



PLEASE READ THESE INSTRUCTIONS CAREFULLY BEFORE STARTING INSTALLATION. LEAVE THESE INSTRUCTION WITH THE USER OR AT THE GAS METER AFTER INSTALLATION

The Benchmark Scheme

Benchmark places responsibilities on both manufacturers and installers. The purpose is to ensure that customers are provided with the correct equipment for their needs, that it is installed, commissioned and serviced in accordance with the manufacturer's instructions by competent persons and that it meets the requirements of the appropriate Building Regulations. The Benchmark Checklist can be used to demonstrate compliance with Building Regulations and should be provided to the customer for future reference.

Installers are required to carry out installation, commissioning and servicing work in accordance with the Benchmark Code of Practice which is available from the Heating and Hotwater Industry Council who manage and promote the Scheme.

Visit www.centralheating.co.uk for more information.

In the interest of continuous development Johnson and Starley reserve the right to change specification without prior notice. Johnson and Starley prides itself on it's ability to supply spare parts quickly and efficiently.

1. FEATURES

Appliance Classification:

This Hi-Spec J40 has been tested and certified by B G Technology for use with NATURAL gas G20.

NOTE: If an ELJAN 6 water circulator is fitted, the relevant Installation, Commissioning and Servicing instructions provided with that appliance must also be observed.

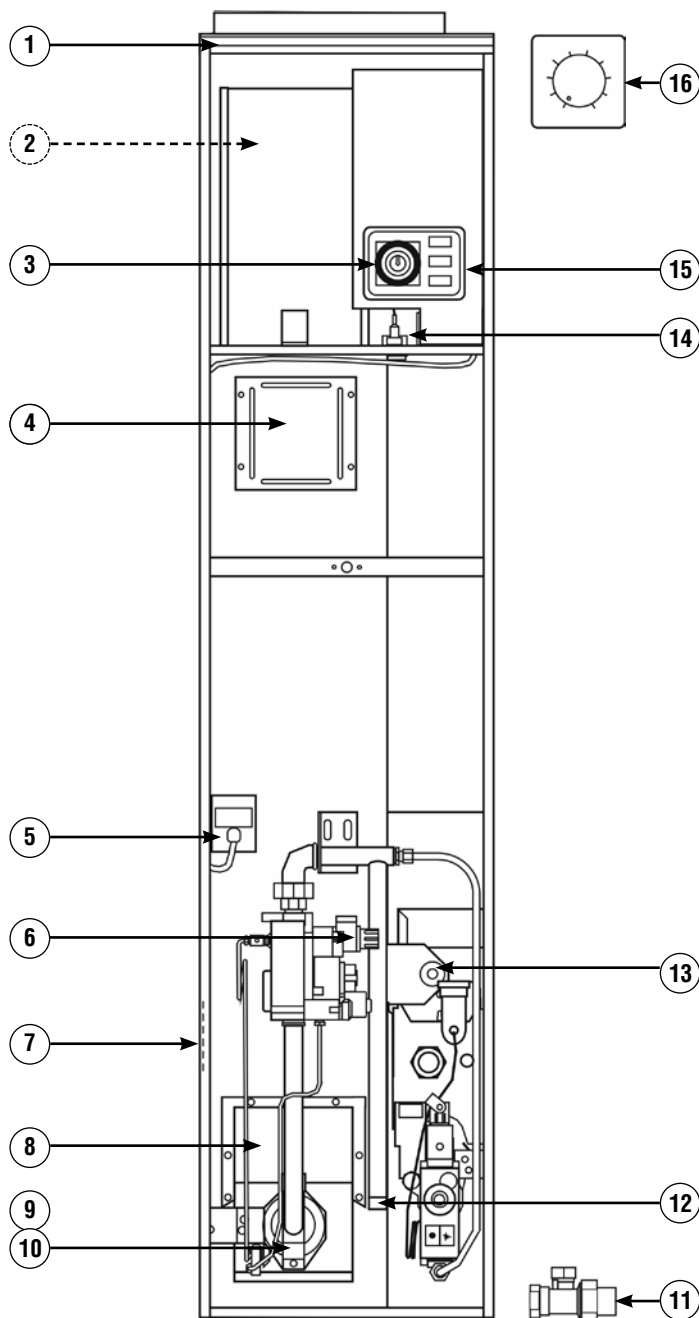

FEATURES

- 1 Air Filter
- 2 Air circulating fan
- 3 Time Clock
- 4 Heat exchanger access cover
- 5 Fan Delay Control /Limit Switch
- 6 Multifunctional Control
- 7 Data plate
- 8 Heat shield
- 9 Pilot Burner
- 10 Burner Assembly
- 11 Gas Cock
- 12 Gas Connection
- 13 Piezo igniter unit
- 14 Spillage monitoring Device (TTB)
- 15 Time Control
- 16 Thermista-stat/Thermostat

FIGURE 1. HI-SPEC J40 FEATURES

2. GENERAL DESCRIPTION

- 2.1 HI-SPEC J40 is an open-flued, fan assisted downflow, ducted warm air heater, which may be supplied with SYSTEM E-T or BASIC control. An ELJAN 6 circulator is available as an option. A Spillage Monitoring Device (TTB) is fitted which senses the temperature in the draught diverter, and shuts down the appliance when this temperature rises due to the presence of flue gases.
- 2.2 The Air heater output can be adjusted between 8.8kW (31.65MJ/h, 30,000Btu/h) and 11.2kW (42.2MJ/h, 40,000Btu/h). "Summer air circulation" of unheated air is available by manual selection (see User's Instructions). ELJAN 6 output is 3.32kW (11.5MJ/h, 11,340Btu/h).

THIS APPLIANCE CONFORMS TO BS EN 45014

3. BUILDING STANDARDS & REGULATIONS



STATUTE LAW DEFINES THAT ALL GAS APPLIANCES MUST BE INSTALLED BY COMPETENT PERSONS, i.e. GAS SAFE REGISTERED INSTALLERS.

GAS SAFE MEMBERSHIP ENQUIRIES TEL: 0800 408 5500 IN ACCORDANCE WITH THE GAS SAFETY (INSTALLATION AND USE) REGULATIONS (CURRENT EDITION).

FAILURE TO COMPLY WITH THESE REGULATIONS MAY LEAD TO PROSECUTION.



3.1 INSTALLATION REGULATIONS

- Gas Safety (Installation and Use) Regulations (as amended)
- Model and Local Authority Byelaws
- Health & Safety Document No. 635.
- The Electricity at Work Regulations
- Institute of Electrical Engineers (I.E.E) Wiring Regulations
- British System Design Manual "Gas Fired Warm Air Heating"
- EN Regulations No. 1196 Supplementary Instructions - Condensing Air Heaters

3.2 BUILDING STANDARDS AND REGULATIONS

Where no specific instructions are given, reference should be made to the relevant British Standard Code of Practice.

Building Standards (Scotland) (Consolidation) Regulations

Building Regulation (Northern Ireland)

Building Regulations Part L

BS 6891 Installation of Low Pressure Gas Pipework of up to 28mm (R1) in domestic premises (2nd family gases).

BS 5440:1 Flues (for gas appliances of rated input not exceeding 70 kW).

BS 5440:2 Ventilation (for gas appliances of rated input not exceeding 70 kW).

BS 5864 Installation of Gas Fired Ducted Air Heaters

BS 5546 Installation of Domestic Hot Water Supplies.

IMPORTANT: This appliance is CE certificated for safety and performance. It is important that no modifications are made to this appliance, unless fully approved in writing by Johnson & Starley Ltd. If in doubt please ring Johnson & Starley Ltd on Telephone 01604 762881.

4. SAFETY & GAS INFORMATION

PLEASE READ THESE INSTRUCTIONS CAREFULLY BEFORE COMMENCING WITH THE INSTALLATION

4.1 GENERAL SAFETY INFORMATION

- 4.1.1 Ensure the mains supply voltage, frequency, number of phases and power rating comply with details on the rating label.
- 4.1.2 All wiring must be in accordance with the appropriate standards. The equipment must be supplied with a double pole isolator switch.
- 4.1.3 Ensure safety regulations and practices are adhered to when installing and using this equipment.
- 4.1.4 The weight of this appliance exceeds that recommended for a one-man lift. It will therefore be necessary to gain assistance at times during the installation procedure.
- 4.1.5 It should be noted that this appliance may contain sharp edges. Care **MUST** be taken when handling the appliance to prevent injury.
- 4.1.6 Once the appliance has been fired beware that certain parts will be hot to the touch.
- 4.1.7 Do not install flues during rain, high winds or in severe weather conditions.

4.2 GAS INFORMATION

4.2.1 Gas Categories

- a. The appliance is certified as a CAT I 2H (20) appliance.

4.2.2 Gas Supply

- a. The gas installation must be completed in accordance with the relevant standards (BS 6891).
- b. The installation must be tested for gas tightness using suitable methods. The Pipework should also be purged of air in accordance with the IG Publication Standard.

5. TECHNICAL DATA

TABLE 1		HI-SPEC J40							
GAS	G20								
GAS SUPPLY PRESSURE	20mbar								
GAS CATEGORY	I 2 H								
COUNTRIES OF INSTALLATION	GB & IE								
ELECTRICAL SUPPLY	230v ~ 50Hz fused 5A (150 watts)								
AIR HEATER									
	LOW RATE			MEDIUM RATE			HIGH RATE		
	KW	MJ/h	Btu/h	KW	MJ/h	KW	KW	MJ/h	Btu/h
INPUT (GROSS)	11.75	42.35	40,100	13.5	48.58	46,050	15.18	54.65	51,800
OUTPUT	8.79	31.65	30,000	10.26	36.92	32,000	11.72	42.2	40,000
GAS RATE CV 1037Btu/FT³	1.08m ³ /h (38.4ft ³ /h)			1.24m ³ /h (44.1ft ³ /h)			1.40m ³ /h (49.8ft ³ /h)		
BURNER SETTING PRESSURE (HOT)	9.2mbar (3.7 in wg)			12.2mbar (4.9 in wg)			16.0mbar (6.4 in wg)		
MAIN INJECTOR	BRAY CAT 23/1050								



GAS LEAKS

DO NOT OPERATE ANY ELECTRICAL SWITCHES, OR USE A NAKED FLAME TURN OFF THE GAS SUPPLY. VENTILATE THE AREA BY OPENING DOORS AND WINDOWS.

CALL THE NATIONAL GAS EMERGENCY SERVICE ON

0800 111999

6. HEATER COMPARTMENT CLEARANCES (see BS 5864)

- 6.1 **IMPORTANT:** If the heater is to be fitted to an existing base duct (warm air plenum), always ensure that installation is carried out such that the rear left hand corner of the heater is aligned with the rear left hand corner of the base duct, so that any overhang or blanking off will be at the front and/or right hand side. In any event, blanking plates must be mechanically secured and all joints sealed.
- 6.2 When the heater is fitted into a compartment consideration should be given to the space required for the removal and replacement of the filter tray and the entry of the gas and electrical supplies.
- 6.3 For service access, a minimum of 500mm (20") is required at the front of the heater. Space must also be allowed, in a compartment installation, to permit the removal of the heater. The clearance between the appliance and the compartment should be not less than 75mm (3"). However, if clearances are less than 75mm, the internal surface of the compartment must be lined with non-combustible material. The compartment must be of a fixed rigid structure.
- 6.4 In airing cupboard installations, the part used as the air heater compartment must comply with the relevant section of BS 5864 and must be completely separated by either a non-combustible partition or a perforated metal partition with the perforations not exceeding 13mm (½"). The secondary flue must be a tight fit where it passes through the partition and must be suitably protected (see BS 5440:Part 1).
- 6.5 In under-stairs installations, the compartment must comply with the relevant section of BS 5864, provided that in addition, all internal surfaces, including the base, are non-combustible or lined with non-combustible material. This requirement is applicable only to dwellings of more than two storeys. Combustible floors must be insulated from the heater.
- 6.6 In free-standing installations, (see instructions packed with free standing kit), only one or two walls will be in contact with the air heater and therefore complying with the relevant section of BS 5864.
- 6.7 If the Air Heater is to be installed onto a combustible surface, a suitable base tray (BT40) is required. However, when a base duct is used, this provides sufficient insulation, and no insulation is required.
- 6.8 For Slot Fix applications (see instructions packed with the Slot Fix Kit), it is important to ensure that the draught diverter relief is maintained on both sides of the application.

7. VENTILATION & COMBUSTION AIR

- 37.1 The room or internal space in which the heater is installed requires a permanent air vent of minimum effective area 62cm² (9in²). The air vent should be either direct to outside air or to an adjacent room or internal space (other than a toilet or bathroom) that itself has an equivalent air vent direct to outside.
Note: The above minimum area assumes that an ELJAN 6 circulator is fitted.
- 7.2 Combustion air may be introduced, via a 127mm (5") nominal bore pipe, connected to a return air duct or plenum from a ventilated area and fitted with a lockable damper. The damper should be adjusted to control combustion airflow to 0.0108m³/s (22.9cfm), (i.e. 0.95m/s [165ft/min] velocity in a 127mm [5"] bore pipe). If this arrangement is used, a non-closeable warm air register **MUST** be provided in the same area as the front of the air heater or heater compartment if a return air grille is not located in that area.
- 7.3 When installed in a compartment, two permanent ventilation openings into the compartment are required, one at high level and one at low level, both communicating either directly with outside air or with a ventilated room or space. The minimum effective areas specified in Table 1 are related to the rated heat input of the Air Heater, and assuming that and ELJAN 6 circulator is fitted.
- 7.4 If any room or area from which air is drawn for ventilation or combustion contains an extract fan, the permanent vents must be sized to ensure that the operation of the appliance(s) at full rate is/are not adversely affected. A spillage test as specified in Safety Checks, paragraph 13.8 (is carried out and any remedial work undertaken).

8. DUCT SYSTEM *(See British Design Manual - Gas fired Warm Air Heating)*

8.1 RETURN AIR

- 8.1.1 Room-sealed appliances may be installed without return air ducting, provided that the path between the return air grille and the appliance return air inlet is protected in such a manner that the required air-flow will be maintained at all times. The return air grille **MUST** have a free area of not less than 1593cm² (291in²). It is recommended that the return air duct not be routed directly from the main living area, but from a convenient central area serving the remainder of the dwelling.
- 8.1.2 The return air system should be constructed of fire-resistant material. The flue shall not be run through an area serving as a return air plenum. It is extremely important that the correct size of return air grilles and ducting is used. For heaters on maximum output the return air duct size should not be less than the equivalent of 300mm x 300mm (12" x 12"). If flexible duct is used the duct diameter should not be less than 350mm (16") dia. The return air grille should have a free area of not less than 1593cm² (291in²).
- 8.1.3 An adequate and unobstructed return air path is essential from areas not served by a directly ducted return and to which warm air is delivered. All such rooms should be fitted with relief grilles which have a free area of 0.0088m²/kW (1in²/250Btu/h) of heat supplied to the room. The only exceptions are kitchens, bathrooms and WCs.
- 8.1.4 The return air duct should allow for ease of removal for access to the flue.
- 8.1.5 All duct work in the room or internal space in which the heater is installed shall be mechanically secured and sealed with ducting tape.

VENTILATED FROM INSIDE BUILDING	Low level grille 352cm ² (54in ²)
	High level grille 176cm ² (27in ²)
VENTILATED FROM OUTSIDE BUILDING	Low level grille 176cm ² (27in ²)
	High level grille 88cm ² (13in ²)

TABLE 2. MINIMUM EFFECTIVE AREAS

8.2 WARM DELIVERED AIR

- 8.2.1 All duct work, including riser ducts, should be fully insulated with 50mm (2") fibreglass or similar. If short extended duct runs are taken below floor level these should be similarly insulated, and in addition wrapped with a sound vapour proof barrier, and protected from crushing.
- 8.2.2 The duct system should be carefully designed (as given in the guidelines in the British System Design Manual) to suit the needs of its specific heating requirements and building layout. The type of duct system, (i.e. radial/extended plenum/stepped) should be installed using the least number of fittings to minimise airflow resistance. The base duct, which equalises the air pressure to supply ducts, shall be constructed to support the weight of the heater, which shall be secured to the plenum with screws on at least two sides, and sealed using self-adhesive foam strip, ducting tape or sealing compound. All ducting and blanking plates shall be mechanically secured and sealed.

9. FLUE INSTRUCTIONS

- 9.1 The installation of the warm air heater and flue system must be in accordance with the Gas Safety (Installation and Use) Regulations 1998 and the Building Regulations. If no specific instructions are given, reference should be made to the relevant codes of practice.

THESE RELEVANT STANDARDS SHOULD BE FOLLOWED

BS 5440:1 Flues and ventilation for gas appliances of rated heating input not exceeding 70kW (net) : Flues

- 9.2 The flue must conform with Building Regulations and British Gas Materials and Installations specification (3rd edition) regarding clearance and shielding from combustible materials.
- 9.3 Ensure all legislation, regulations and directives mentioned are observed.
- 9.4 Ensure while installation work is being carried out that no debris such as swarf, filings or fragments of mortar are allowed to remain in the air/flue duct.

9.5 FLUE INSTALLATION

The Hi-Spec J40 is designed to be used with a 60/100mm (4") flue.

- 9.5.1 All joints must be soundly sealed.
- 9.5.2 The flue should be kept as short and warm as possible.
- 9.5.3 Sufficient support brackets must be used in order to support the total weight of the flue system.
- 9.5.4 The spigot connection of the heater draught diverter will accept internally the spigot end of a non-asbestos flue to BS 567 or twin wall metal flue to BS 715 of nominal 100mm (4") diameter.
- 9.5.5 A split collar should be fitted to provide for flue maintenance or inspection.
- 9.5.6 The flue shall be in accordance with the Building Regulations and British Gas Materials and Installations specification (3rd edition) with regard to clearance and shielding from combustible materials.
- 9.5.7 All materials shall be in accordance with Building Regulations requirements.
- 9.5.8 The flue should run as vertically as possible. Horizontal runs should be avoided if at all possible and any directional change should be as gentle as possible. If there is any doubt about the flue configuration, the equivalent flue height should be determined, see paragraph 9.5.10.
- 9.5.9 If the appliance to be fitted is a replacement, the old appliance should be checked for signs of spillage prior to commencement of the installation and appropriate action taken. (i.e. check flue system and renew as necessary).
- 9.5.10 It is recommended that at least 600mm of vertical flue should be provided from the top of the draught diverter (for new installations this shall be incorporated into the flue design). However, when carrying out replacement installations, an existing flue system may be encountered, where the vertical flue above the appliance to the first bend is less than 600mm. In the first instance, the installer must judge whether this distance can be achieved practicably by some means. Where this is not practicable, the existing flue system may be used, providing there is no evidence of spillage from the old appliance, see paragraph 9.5.9. Every effort must be made, however, to ensure that the existing flue complies in every other way to BS 5440 Part 1, including the visual inspection, flue flow and spillage test described 4.3.2 of the above standard. Flue configurations may be assessed in terms of equivalent vertical height - details are given below. For air heaters, the minimum equivalent vertical height is 1 metre. The installer must make a judgement based on his knowledge and experience and the examination and testing described above as to whether an existing flue system can be used.

NOTE: Ventilation of the compartment, room or internal space in which the appliance is to be installed must be checked for compliance with the requirements of BS 5440 Part 2 (Ref. Section 3 of these instructions) and upgraded as necessary.

- 9.5.11 Calculation method for flue sizing: (BS 5440: Part 1, Appendix A)

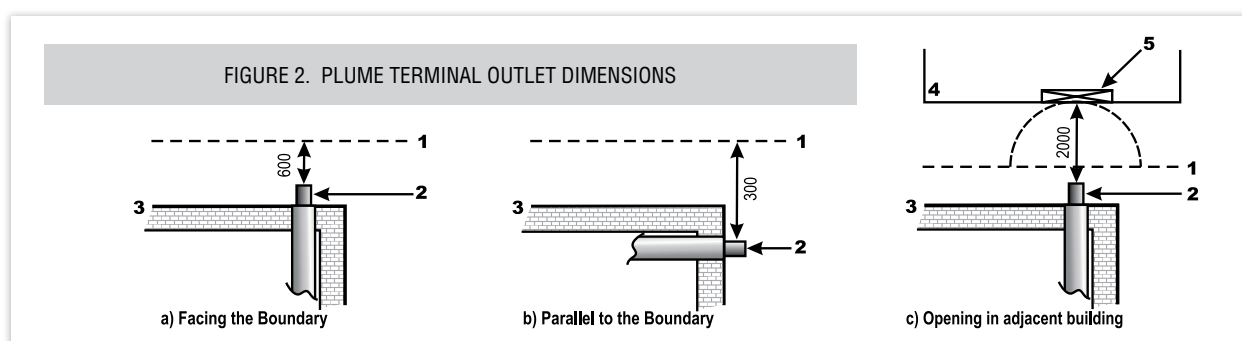



FIGURE 3. TERMINAL POSITIONS

TABLE 3	TERMINAL POSITION	MINIMUM DISTANCE
A	Directly below an opening, air brick, opening window etc	300mm
B	Above an opening, air brick, opening window, etc.	300mm
C	Horizontally to an opening, air brick, opening window etc.	300mm
D	Below gutters, soil pipes or drain pipes.	75mm
E	Below eaves.	200mm
F	Below balconies.	200mm
G	From a vertical drain pipe or soil pipe.	150mm
H	From an internal or external corner. Greater than 450mm protrusion.	300mm
I	Above ground, roof or balcony level.	300mm
J	From a surface facing the terminal.	600mm
K	From a terminal facing the terminal.	1,200mm
M	Vertically from a terminal on the same wall.	1,500mm
N	Horizontally from a terminal on the same wall.	300mm
Q	Above intersection with roof.	530mm
P	From a vertical structure on the roof	300mm
R	From the terminal to the boundary	300mm

- a. This appendix provides a procedure for estimating whether a given flue design is likely to ensure full clearance of combustion products.
- b. The procedure is based on calculating the 'equivalent height' of the flue under consideration, i.e. that height of the straight vertical circular flue pipe of specific size which will produce the same flow rate as the flue under consideration. The equivalent height is calculated from the formula:

$$H_e = H_a \times \frac{(K_i + K_o)_e}{(K_i + K_o)_a - K_e H_a + \text{Sum K}}$$

where:

H_e is the height of the equivalent flue;

H_a is the vertical height of the actual or proposed flue;

K_i is the inlet resistance of the flue;

K_o is the outlet resistance from the flue;

subscript e refers to the equivalent flue diameter;

subscript a refers to the actual or proposed flue diameter;

K_e is the resistance per unit length of the equivalent flue;

Sum K is the resistance (other than the inlet and outlet resistance) of the actual or proposed flue.

NOTE: K and Sum K are obtained from Table 2. K_o and K_i are obtained from Table 5.

- c. Table 2 gives resistance factors for common flue components for use in the formula. Table 5 contains the appropriate inlet and outlet flue resistances. The flue is likely to be satisfactory if its equivalent height exceeds 1m.

COMPONENT	INTERNAL SIZE	RESISTANCE FACTOR
Flue Blocks	197mm x 67mm	0.85 per meter run
	231mm x 65mm	0.65 per meter run
	317mm x 63mm	0.35 per meter run
	140mm x 102mm	0.60 per meter run
	200mm x 75mm	0.60 per meter run
	183mm x 90mm	0.45 per meter run
Pipe	100mm	0.78
	125mm	0.25
	150mm	0.12
Chimney	213mm x 213mm	0.02
90° Elbow	100mm Pipe	1.22 per fitting
	125mm Pipe	0.50 per fitting
	150mm Pipe	0.24 per fitting
45° Elbow	100mm Pipe	0.61 per fitting
	125mm Pipe	0.25 per fitting
	150mm Pipe	0.12 per fitting
	197mm x 67mm	0.30 per fitting
	231mm x 65mm	0.22 per fitting
	317mm x 63mm	0.13 per fitting
Raking Block	Any	0.30 per block
Adaptor Block	Any	0.50 per block
Terminal	100mm Ridge	2.5
	125mm Ridge	1.0
	150mm Ridge	0.48
	100mm GCI	0.6
	125mm GCI	0.25
	150mm GCI	0.12

TABLE 4. RESISTANCE FACTORS FOR USE IN CALCULATING EQUIVALENT LENGTHS

APPLIANCE	INLET RESISTANCE (K _i)	FLUE	OUTLET RESISTANCE (K _o)
100mm Dia Spigot	2.5	100mm Flue	2.5
125mm Dia Spigot	1.0	125mm Flue	1.0
150mm Dia Spigot	0.48	150mm Flue	0.48

TABLE 5. INLET & OUTLET RESISTANCE

d. Worked Calculation Example

A warm air unit with a 100mm (4") diameter flue spigot, fitted with a prefabricated flue system leading to a ridge tile in the loft. Refer to Figure 4.

From Table 3

K _{ia}	Inlet resistance of actual flue	=	2.5
K _{oa}	Outlet resistance of actual flue	=	2.5
K _{ie}	Inlet resistance of equivalent flue	=	2.5
K _{oe}	Outlet resistance of the actual flue	=	2.5

From Table 2

Other resistances of actual flue:

Terminal	=	2.5
Pipe bend (2 x 0.61)	=	1.22
Pipe (4 x 1m @ 0.78)	=	3.12
(5 x 0.3m @ 0.78)	=	1.17
Sum K	=	8.01

Equivalent height

From the formula

$$H_e = 6.2 \times \frac{(2.5 + 2.5)}{(2.5 + 2.5) - (0.78 \times 6.2) + 8.01}$$

H_e = 3.793 This flue exceeds 1.0m equivalent height and is therefore satisfactory.

NOTE: Ventilation of the compartment, room or internal space in which the appliance is to be installed must be checked for compliance with the requirements of BS 5440 Part 2, Refer to section 3 of these instructions and upgraded as necessary.

9.5.12 Special consideration must be given to external flues with a view to prevention of condensation and weathering problems.

9.5.13 An approved terminal should always be used; a ridge terminal or "GC1" terminal is specifically recommended. The latter should be positioned in a free air space where it is not shielded by any structure. A minimum of 1m (3ft.) from any vertical or inclined roof structure must be allowed for.

9.5.14 Where flue blocks are used, builders should ensure that no obstruction is created during erection. The installer should ensure that the connection flue does not project beyond the internal wall of the flue blocks and that there is provision for examination and servicing.

9.5.15 **IMPORTANT:** Before installing the appliance, carry out a visual check of the flue system as directed in the relevant section of BS 5440 Part1, then check the flue performance as follows:-

- Close all doors and windows in the room in which the appliance is to be installed.
- Introduce some heat into the flue, using a blow torch or other means.
- Carry out a flow visualisation check with a smoke pellet at the intended position for the appliance. Ensure that there is discharge of smoke from the correct terminal only, and no spillage into the room. Smoke coming out of other than the correct terminal only, or a down draught or 'no flow' condition, indicates that the flue has failed the test, and the appliance shall not be connected until the defect has been found and rectified, and the test satisfactorily completed.

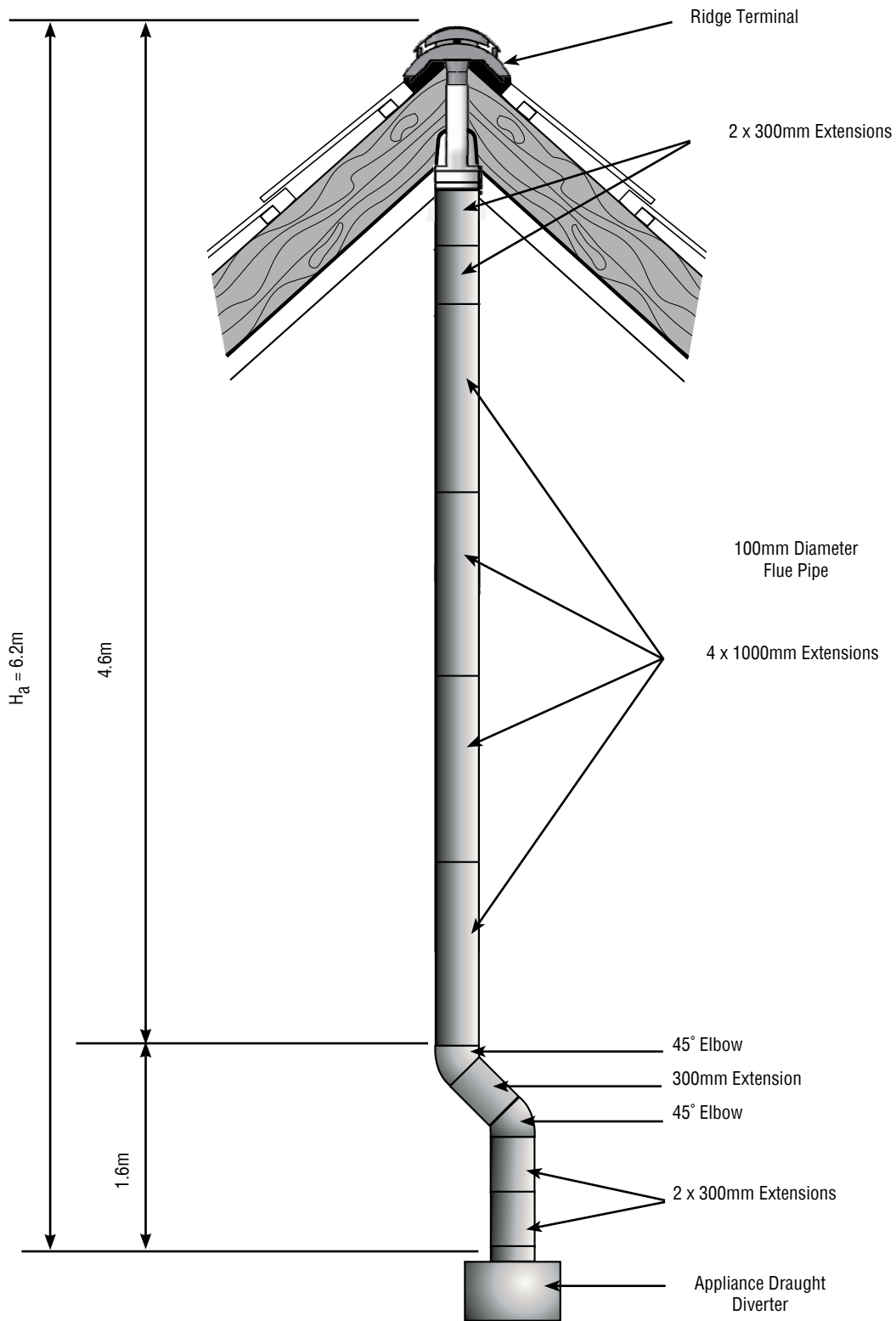

TABLE 4. WORKED EXAMPLE OF EQUIVALENT FLUE HEIGHT

10. ELECTRICAL

WARNING: THIS APPLIANCE MUST BE EARTHED!

10.1 MAINS SUPPLY

- a. The heater is supplied with mains cable (PVC sheathed, heat resisting to 85°C), 3-core Brown-Blue-Green/Yellow, 6A, 0.75mm²), connected to a terminal block and exiting through the heater at the right hand top. The cable is suitable for a 230V 50Hz supply and shall be connected to the fixed wiring using a double pole switched, fused spur, incorporating a protective earth link. The fuse fitted shall be rated 5A to BS 1362. Connections shall be in accordance with the current edition of I.E.E Regulations BS 7671.
- b. Fan Delay Control and Limit Switch are not adjustable and are set as follows:
 - i. **BASIC Models** Fan delay control closes at 54°C± 4.5°C; opens at 40°C±3°C.
 - ii. **All Models** Limit Switch opens at 80°C; closes at 60°C.
- c. **SYSTEM E-T MODELS** An electronic controller (Thermista-stat) is supplied which acts as a room thermostat.
- d. **BASIC MODELS** A 24V room thermostat (not supplied), that complies with BS 800, BS 3955 and BS 4201 is essential to ensure close control of comfort conditions. An anticipator is located within the thermostat and is graded in amps. The anticipator should be checked and adjusted to 0.2A.

10.2 THERMISTA-STAT & IT'S LOCATION

- a. The thermista-stat should be located where there is free air circulation and positioned approximately 1.5m (5ft) from the floor.
- b. Avoid the following locations:
 - i. In a room where temperature is greatly affected by the sun or any other heat source, e.g. radiant fire, wall light fittings or TV set.
 - ii. Near an outside door or windows, or on an outside wall.
 - iii. Where it will be affected by warm air ducts, diffusers, waste pipes or the heater itself.
 - iv. Where it will be subjected to vibration.
- c. Connect the thermista-stat wires to terminals '7' and '8' on the terminal block, see Figure 14 & 15..

11. GAS (See BS 5864 and BS 6891)

- 11.1 The local gas supply conditions MUST be adequate for the specified burner pressures as stated in the technical specification (paragraph. 1.3)
- 11.2 An independent gas supply pipe from the meter is to be preferred wherever possible. Where this is not possible, the pipe must be capable of taking the complete input of the heater and all other gas appliances being served by the same pipe. This supply should be suitably sized to conform to British Standards requirements of no more than 1.0 mbar (0.4" wg) pressure drop (See Table of discharge in BS 6891).
- 11.3 The ½" union gas cock (supplied) MUST be fitted to the gas inlet of the heater for easy isolation during servicing. The gas pipe should be fitted and installed so as to be durable, substantial and gas tight. To assist in determining where a gas connection may not be tight, a leak detection fluid should be applied around the connection. Under no circumstances should a flame be used to locate a gas leak. Gas entry to the air heater is through either side to a a Rp ½ (½" BSP. internal [parallel] thread).

12. FITTING INSTRUCTIONS

CAUTION: This appliance exceeds the recommended weight for a one man lift as detailed in the Manual Handling Operations, 1992 Regulations.

It should be noted that this appliance could contain sharp edges and care MUST be taken when handling.

12.1 FITTING THE APPLIANCE

- 12.1.1 Making sure the plenum is clear from all debris, lift the appliance into place.
- 12.1.2 Using a spirit level it is important the appliance is completely level, this appliance MUST NOT lean or tilt in any direction. This will cause problems with the condense draining.
- 12.1.3 Seal the unit to the plenum, using ducting tape (not supplied). Ensure a good seal is made.
- 12.1.4 Fix all connections to the appliance ready for commissioning.

13. COMMISSIONING

13.1 PREPARATION

After installation of the appliance, you **MUST** do the following:

- 13.1.1 Test for gas leakage using proprietary detection fluid and seal any leaks found.
- 13.1.2 Carry out preliminary electrical system checks.
- 13.1.3 Ensure that:
 - a. filter, fan and fan compartments are free from obstructions.
 - b. all registers or grilles are open and conform to design specifications.
 - c. return, relief and ventilation air installations are adequate.



FIGURE 5.
ELECTRICAL DOOR ASSEMBLY

13.2 SYSTEM BALANCING

- 13.2.1 Set the air heater electrical supply **ON**.
- 13.2.2 Set the thermista-stat to the "SUMMER AIRFLOW" position 'I'.
- 13.2.3 Balance the system to provide the required volume proportions at the warm air outlets.

NOTE: If the system includes ceiling diffusers, the air through these should be **NOT LESS THAN 1.5m/s (300ft/min)**, except for very small rooms, (i.e. bathrooms etc.). Outlet faces may require partial blanking in order to achieve this.

- 13.2.4 Set the SUMMER AIRFLOW switch to '0'.

13.3 LIGHTING IGNITION & MAIN BURNER

WARNING: If the pilot light is extinguished either intentionally or unintentionally, no attempt should be made to relight the gas for a minimum of 3 minutes. Ensure Electrical supply, time control and Selector switches are set to '**OFF**'.

- 13.3.1 Set the Thermista-stat/room thermostat to its lowest or **OFF** setting.
- 13.3.2 On the Multifunctional Control, remove the Outlet Pressure test point cover, and fit a pressure test gauge, refer Figure 9.
- 13.3.3 Turn the heater Gas supply **ON**, test for gas tightness and purge the whole gas pipe as described in BS 6891.
- 13.3.4 Referring to Figure 9, press and hold the OPERATING CONTROL, and whilst observing the Pilot Burner, repeatedly press the Piezo igniter button until the Pilot Burner ignites.
- 13.3.5 After 20 seconds release the Multifunctional Control OPERATING CONTROL and let it spring out; ensure that the Pilot Burner remains alight. If the Pilot Burner extinguishes, rotate the OPERATING CONTROL clockwise to the '●' position and ensure that the OPERATING CONTROL is fully reset. Wait three minutes and repeat steps 13.3.4 and 13.3.5, holding the OPERATING CONTROL depressed for a longer period, until the Pilot burner remains alight.
- 13.3.6 With the Pilot Burner lit, depress the OPERATING CONTROL and turn it to the position indicated by the flame symbol.
- 13.3.7 Ensure that the pilot flame envelops the thermocouple tip, see Figure 7.
- 13.3.8 Set the Heater Electricity supply **ON**.
- 13.3.9 Set the Time Control to the required Heating On periods.
- 13.3.10 Set the Selector switch to 'TIMED'.
- 13.3.11 Set the Thermista-stat or room thermostat to **MAXIMUM**.
- 13.3.12 Ensure that the Main Burner has now ignited.
- 13.3.13 Test for gas leakage at the supply, Multifunctional Control, Pilot and Main Burners using proprietary detection fluid, sealing any leaks found.
- 13.3.14 Allow the heater to operate for a minimum of 15 minutes to ensure stability.

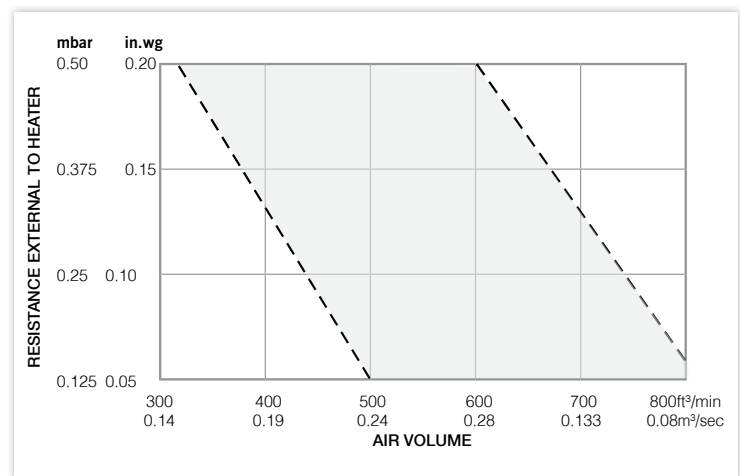

FIGURE 6. FAN PERFORMANCE GRAPH

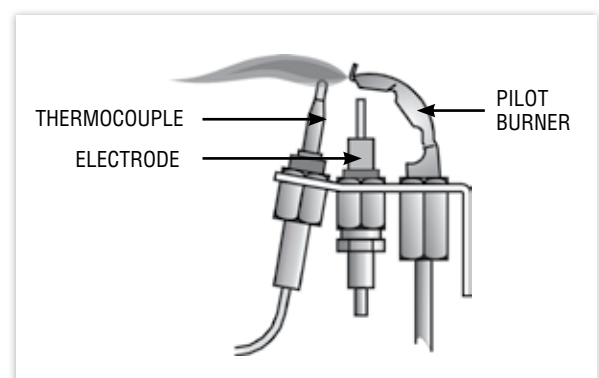

FIGURE 7. ELECTRICAL DOOR ASSEMBLY

13.4 MAIN BURNER PRESSURE TEST

NOTE: AIR HEATER BURNERS ARE FACTORY SET TO PROVIDE A NOMINAL HIGH RATE OUTPUT AS DETAILED IN PARAGRAPH 2.2

13.4.1 Referring to Table 1 and Figure 9 below, ensure that the pressure test gauge indicates the correct burner pressure, resetting if required as follows:

AT THE MULTIFUNCTIONAL CONTROL

- i. Remove the Burner Pressure Adjuster cover.
- ii. Set the Burner Pressure Adjuster to provide a pressure test gauge indication for the correct burner pressure as detailed in Table 1.
- iii. Refit the Burner Pressure Adjuster cover.

13.4.2 Apply the pressure set arrow to indicate the appropriate burner pressure on the data badge.

13.5 EXTINGUISHING OF PILOT AND MAIN BURNERS

13.5.1 On the Multifunctional Control, rotate the OPERATING CONTROL clockwise to the '●' position and ensure that the OPERATING CONTROL fully resets, and both the Pilot and Main Burners are extinguished.

13.5.2 On the Multifunctional Control, remove the pressure test gauge and refit the Outlet Pressure test point cover.

13.6 TEMPERATURE RISE CHECKS

13.6.1 Ignite the Pilot and Main Burners and allow 15 minutes for stability before continuing.

13.6.2 Check the temperature rise across heater is between 45°C - 55°C, setting the fan speed as follows:

i. SYSTEM E-T HEATER

System E-T provides a fan speed corresponding to the above temperature rise, if the appliance is to be set to operate at the minimum rate and the ducting has been sized accordingly, set the 'RATE SWITCH' to 'MIN', thus reducing the fan speed.

ii BASIC HEATER

The fan speed is adjusted by selecting the fan speed at control panel (decrease voltage selection to decrease fan speed).

NOTE: Tapping 1 = 210V, tapping 2 = 200V, tapping 3 = 190V, tapping 4 = 180V, tapping 5 = 170V.

13.7 AUTOMATIC CONTROLS CHECK

13.7.1 Ignite the Pilot and Main Burners and allow to operate for 15 minutes to ensure stability.

13.7.2 Set the TIME CONTROL to 'ON'.

13.7.3 Turn the Thermosta-stat or room thermostat slowly clockwise until the Main Burner ignites.

13.7.4 Ensure that the fan starts to operate after a short period, approximately 1-2 minutes.

SYSTEM E-T MODELS

13.7.5 Ensure that the fan speed increases to full speed.

13.7.6 When the temperature reaches the control setting, check that the Main Burner cycles ON and OFF, at approximately 75 to 120 seconds.

BASIC MODELS

13.7.7 When the temperature reaches the control setting, ensure that the Main Burner extinguishes followed by the fan switching off after a short period.

13.7.8 When the temperature falls below the control setting, ensure that the Main Burner re-ignites followed by fan operation.

13.8 SAFETY CHECK

13.8.1 Check for gas soundness within the appliance.

13.8.2 SPILLAGE TEST

Carry out a full spillage test as follows, and ensure that the flue operates effectively with all doors closed and any extractor fans in operation.

NOTE: If an extractor fan is situated in an adjoining or adjacent room, carry out the spillage test with the interconnecting doors open.

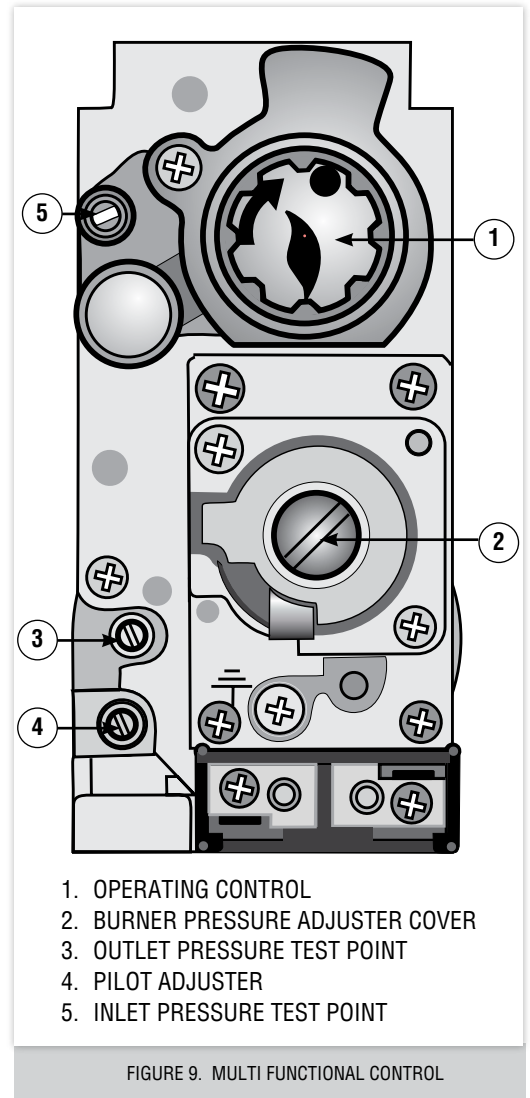

IF THE DRAUGHT DIVERTER IS ACCESSIBLE

- a. Introduce smoke into the draught diverter adjacent to an exit from the heat exchanger, by means a smoke match or puffer.
- b. Ensure that there is no spillage present (indicated by displacement of smoke downwards and out of the draught diverter).

IF THE DRAUGHT DIVERTER IS NOT ACCESSIBLE

- a. Introduce smoke, by means of **part** of a smoke pellet on a non-combustible support, into the heat exchanger.
- b. Extinguish the Main and Pilot burners.
- c. Ensure that there is no spillage evident by visually observing the draught diverter location on the air heater.
- d. If spillage is evident, further investigation and rectification is required before re-testing the appliance.
- e. **Repeat spillage tests but with the fan running, or Summer Airflow switch set to ON.**

WARNING: The appliance shall not be left connected to the gas supply unless it has successfully passed the above spillage test.

- 13.8.3 Turn OFF the gas supply at the service cock and ensure that the Multifunctional control fail-safe operates within 60 seconds (indicated by loud click from Multifunctional control).
- 13.8.4 Turn gas supply ON at service cock.
- 13.8.5 Switch the appliance electrical supply OFF.
- 13.8.6 Disconnect the Air Circulation Fan at the flying lead socket.
- 13.8.7 Switch the appliance electrical supply ON.
- 13.8.8 Ignite the Pilot and Main Burners as detailed in 6.3.1 to 6.3.5.
- 13.8.9 Ensure that the Limit Switch operates, indicated by the main burner extinguishing, within 120 and 180 seconds.
- 13.8.10 Switch the appliance electrical supply OFF.
- 13.8.11 Reconnect the Air Circulation Fan.
- 13.8.12 Switch the appliance electrical supply ON.
- 13.8.13 Ensure that the Main Burner re-ignites when the appliance temperature reduces, (note: with the Air Circulation Fan disconnected, there may be some delay before the Main Burner re-ignites).

14. USERS INSTRUCTIONS

- 14.1 If the building is unoccupied, ensure that the user instructions are left taped to the air heater for the user's reference and that the installation instructions are left at or near the air heater for use on future service calls.
- 14.2 If the building is occupied, hand the user instructions over and ensure that the user understands:
 - 14.2.1 How to ignite the pilot and burner.
 - 14.2.2 How to operate the Thermista-stat/room thermostat, time and heater ON/OFF switch and summer air circulation switch, and that the time control must be reset following a power failure.
 - 14.2.3 How to extinguish the pilot and main burner at the Multifunctional control, and switch off the electrical supply to the heater.
 - 14.2.4 How to remove, clean and refit the air filter and at what intervals (i.e. fortnightly, or weekly for new houses).
 - 14.2.5 How to control the heating system by opening and closing warm air outlets.
 - 14.2.6 How to obtain summer air circulation.
 - 14.2.7 That the air grilles on the heater or heater compartment; grilles and ventilators in the walls, windows or doors of the building **MUST NOT BE OBSTRUCTED.**
 - 14.2.8 That the heater must be serviced at least once a year by a competent person to ensure efficient and safe operation.
 - 14.2.9 That the red instructions for safe use have been pointed out and understood.
 - 14.2.10 That expert help must be obtained if persistent failure of the pilot burner occurs.

NOTE

This appliance is not intended for use by persons (including children) with reduced physical, sensory or mental capabilities, or lack of experience and knowledge, unless they have been given supervision or instruction concerning use of the appliance by a person responsible for their safety.

Children should be supervised to ensure that they do not play with the appliance.



REMINDER: At the time of commissioning, complete all relevant sections of the Benchmark Checklist located on the inside back pages of this document prior to handing over the appliance to the occupier.

15. SERVICING & MAINTENANCE

IMPORTANT: Ensure that the gas and electricity supplies are isolated before commencing any servicing & maintenance or replacement of components. Because the appliance is room sealed, it is also imperative that if at any stage of repairs the gasket on the sealing plate is damaged it **MUST** be replaced! After completion of any maintenance, always test for gas tightness and carry out a complete functional test of the appliance in accordance with the Commissioning Instructions at paragraphs 13.1 to 13.6 inclusive.

15.1 ROUTINE MAINTENANCE

- 15.1.1 Operate the appliance and check for the correct function of the burner and controls.
- 15.1.2 Turn OFF the gas and electrical supplies to the appliance.
- 15.1.3 Remove the air heater front panel.
- 15.1.4 Remove and check the return air filter/cleaner for cleanliness, remove and clean the Air Circulation fan as detailed in paragraph 15.8.
- 15.1.5 Remove the Burner and Controls Assembly as detailed in para 8.2. Inspect and clean the Main Burner and injector as necessary. Examine the Main Burner for cracks, including hairline cracks, exchanging the burner as necessary.
- 15.1.6 Inspect and clear the pilot burner orifice.
- 15.1.7 Clean the heat exchanger flueways by thoroughly brushing from above and below.
- 15.1.8 By viewing through the Fan Aperture, and using a torch or similar, examine the heat exchanger externally for signs of cracks or holes, particularly around welded joints.
- 15.1.9 Using a torch or similar, introduce a light source into the heat exchanger burner aperture and upper access port, and again examine the heat exchanger for signs of cracks or holes, particularly around welded joints, whilst again viewing through the Fan Aperture.
- 15.1.10 Refit the Air Circulation fan, Burner and Controls Assembly, and air filter/air cleaner.
- 15.1.11 Light the appliance and note the main burner flame profile. If the flame profile is affected when the Air Circulation fan switches on, check for any air leaks between the air heater and the base plenum, paying particular attention to heaters with rear draught diverters. Rectify any air leaks before continuing with this procedure.
- 15.1.12 Allow the air heater to operate for approximately 15 minutes to ensure stability, and with the main burner lit, ensure that the operation of Air Circulation fan does not affect the main burner flame profile.

15.2 BURNER & CONTROL ASSEMBLY REMOVAL

- 15.2.1 Ensure that the Gas and Electrical supplies are switched OFF
- 15.2.2 Remove the appliance lower door.
- 15.2.3 Disconnect the igniter at the Piezo unit.
- 15.2.4 Disconnect the Multifunctional Control electrical connections.
- 15.2.5 Disconnect the gas supply by breaking the union at the input side of the Multifunctional Control.
- 15.2.6 Release the burner assembly fixing screw at the left hand side of the burner bar and withdraw the Burner and Controls Assembly
- 15.2.7 Refit the Burner and Controls Assembly in reverse order.

15.3 BURNER & CONTROLS ASSEMBLY CLEANING

- 15.3.1 Remove the Burner and Controls Assembly as detailed in 15.2.
- 15.3.2 Remove the 2 screws securing the gas feed pipe to the burner bar, and remove the burner bar.
- 15.3.3 Clean the burner thoroughly both inside and out with a soft brush. **DO NOT ENLARGE, DISTORT OR DAMAGE BURNER HOLES.**
- 15.3.4 Reassemble in reverse order.

15.4 MAIN INJECTOR REMOVAL, CLEANING & REPLACEMENT

- 15.4.1 Remove the Burner and Controls Assembly as detailed in 15.2.
- 15.4.2 Unscrew the main injector from the housing.
- 15.4.3 Clean as necessary. **DO NOT ENLARGE, DISTORT OR DAMAGE THE MAIN INJECTOR HOLE.**
- 15.4.4 If the injector is to be replaced, ensure that it is correctly marked, referring to the data badge for details.
- 15.4.5 Refitment or replacement is in reverse order.

15.5 PILOT BURNER, THERMOCOUPLE & ELECTRODE REMOVAL AND REPLACEMENT

- 15.5.1 Remove the Burner and Controls Assembly as detailed in 15.2
- 15.5.2 Disconnect the Igniter lead from the Electrode.
- 15.5.3 Release the Pilot Feed Pipe from the pilot injector.
- 15.5.4 Release the retaining nut and withdraw the Thermocouple from the Pilot Burner Assembly, taking care to avoid causing damage to the capillary.
- 15.5.5 Release the Electrode securing nut from the Pilot Burner Assembly and withdraw the Electrode.

15.5.6 Release the two screws securing Pilot Burner Assembly to the main burner, and remove Pilot Burner Assembly.

15.5.7 Refitting or replacement is in reverse order.

NOTE: When refitting or replacing Thermocouple, tighten only to FINGER TIGHT + 1 FLAT.

15.6 MULTIFUNCTIONAL CONTROL REMOVAL

15.6.1 Remove the Burner and Controls Assembly as detailed in 15.2

15.6.2 Disconnect the Thermocouple at the Multifunctional Control, avoiding damage to the capillary.

15.6.3 Disconnect the Pilot Feed Pipe from the Multifunctional Control.

15.6.4 Disconnect Multifunctional Control input and output supply feeds.

15.6.5 Refitting or replacement is in reverse order.

NOTE: When refitting or replacing the Multifunctional Control, the 'O' ring seal is to be replaced.

15.7 PIEZO UNIT REMOVAL

15.7.1 Disconnect the 2 conductors from Piezo unit.

15.7.2 Release the retaining nut and remove the Piezo unit from its mounting bracket.

15.7.3 Refitting or replacement is in reverse order.

17.8 AIR CIRCULATING FAN, REMOVAL & CLEANING

15.8.1 Ensure that the electrical supply is isolated.

15.8.2 Remove the appliance upper and lower doors, release the securing screw and hinge down the fan chamber door.

15.8.3 Disconnect the fan flying leads from the Fan Assembly.

15.8.4 Release the Fan Assembly securing screw and withdraw the Fan Assembly from the Heater cabinet, avoiding damage to the fan blades.

15.8.5 Remove all dust from both the impeller and motor, taking care to not disturb the balance of the fan.

15.8.6 Refitting or replacement is in reverse order.

15.9 ELECTRICAL ASSEMBLY REMOVAL

15.9.1 Ensure that the electrical supply is isolated.

15.9.2 Remove the appliance upper and lower doors, release the securing screw and hinge down the fan chamber door.

SYSTEM E-T models

15.9.3 Disconnect the following

- a. Air circulation fan flying leads from the capacitor,
- b. 230V mains 'L', 'N' and 'E' from connection block terminals '1' and '2', and Earth Stud respectively,
- c. Thermista-stat connections from connection block terminals '7' and '8',
- d. Limit Switch from connection block terminals '13' and '14',
- e. Fan Delay Control from connection block terminals '18' and '17',
- f. Multifunctional Control from connection block terminals '16' (N) and '15' (L),
- g. Water heater from connection block terminals '10' (L) and '9' (N),
- h. Water Pump from connection block terminals '12' (L) and '11' (N),
- i. Cleanflow from connection block terminals '19' (24V) and '20' (0V),
- j. Earth lead from the fan chamber floor,

BASIC models

17.9.4 Disconnect the following

- a. Air circulation fan flying leads from the Fan assembly,
- b. 230V mains 'L', 'N' and 'E' from connection block terminals '1' and '2', and Earth Stud respectively,
- c. Room thermostat connections from connection block terminals '7' and '8',
- d. Limit Switch from connection block terminals '13' and '14',
- e. Fan Delay Control from connection block terminals '18' and '17',
- f. Multifunctional Control from connection block terminals '16' (N) and '15' (L),
- g. Water heater from connection block terminals '10' (L) and '9' (N),
- h. Water Pump from connection block terminals '12' (L) and '11' (N),
- i. Cleanflow from connection block terminals '19' (24V) and '20' (0V),
- j. Earth lead from the fan chamber floor,

BOTH MODEL TYPES

17.9.5 Disconnect the 2 x Spillage switch connections from terminal block terminal '15', and the relay module 'COMM' terminal.

17.9.6 Release the 2 x screws from the hinged access door and withdraw the Electrical Assembly, releasing wiring from cable clamps and grommets as required..

17.9.7 Refitting or replacement is in reverse order.

15.10 ELECTRONIC MODULE REMOVAL (SYSTEM E-T models only)

- 15.10.1 Ensure that the electrical supply is isolated.
- 15.10.2 Remove the appliance upper and lower doors, release the securing screw and hinge down the fan chamber door.
- 15.10.3 Disconnect terminals '21' to '33' from the Electronic Module.
- 17.10.4 Release the 2 x screws and nuts securing the Electronic Module to the Electrical Assembly and remove the module.
- 15.10.5 Refitting or replacement is in reverse order.

15.11 TRANSFORMER REMOVAL (BASIC models only)

- 15.11.1 Ensure that the electrical supply is isolated.
- 15.11.2 Remove the appliance upper and lower doors, release the securing screw and hinge down the fan chamber door.
- 15.11.3 Disconnect the conductors from the Transformer.
- 15.11.4 Release 2 x screws and nuts securing Transformer to Electrical Assembly, and remove the Transformer.
- 15.11.5 Refitting or replacement is in reverse order.

15.12 TIME CONTROL & SWITCH REMOVAL

- 15.12.1 Ensure that the electrical supply is isolated.
- 15.12.2 Remove the appliance upper and lower doors, release the securing screw and hinge down the fan chamber door.

TIME CONTROL REMOVAL

- 15.12.3 Disconnect conductors 'C1', 'C2', 'C3' and 'C5' from the Time Control.
- 15.12.4 Release the 2 x fixing screws, and withdraw the Time Control.
- 15.12.5 Refitting or replacement is in reverse order.
- 15.12.6 Set the Time Control to the required ON and OFF times.
- 15.12.7 Set the Time Control to the correct time.

SWITCH REMOVAL

- 15.12.8 Disconnect the conductors from the switch terminals.
- 15.12.9 Depress the retaining clips and press the switch out of the fascia panel.
- 15.12.10 Refitting or replacement is in reverse order.

WARNING: The fascia panel is held in place by push fit retainers which must be removed with caution to avoid causing damage to the support pins. Removal of the fascia is not advised unless it is intended to be replaced.

15.13 FAN DELAY CONTROL/LIMIT SWITCH REMOVAL

- 15.13.1 Ensure that the electrical supply is isolated.
- 15.13.2 Remove the appliance upper and lower doors, release the securing screw and hinge down the fan chamber door.
- 15.13.3 Disconnect the following at the Electrical panel:
 - a. Limit Switch from connection block terminals '13' and '14',
 - b. Fan Delay Control from connection block terminals '18' and '17',
 - c. Earth connection from common earth stud.
- 15.13.4 Release 2 x 4mm screws securing the Limit switch mounting plate, and withdraw the control from the appliance by drawing the conductors through the grommet in the fan chamber floor.
- 8.13.6 Refitting or replacement is in reverse order.

15.14 SPILLAGE MONITORING DEVICE (TTB) REMOVAL

- 15.14.1 Ensure that the electrical supply is isolated.
- 15.14.2 Remove the appliance louvre door, release the securing screw and hinge down the fan chamber door.
- 15.14.3 Disconnect the TTB from its conductors.
- 15.14.4 Release 2 x screws securing the TTB Bracket to the fan chamber floor, and withdraw the TTB Bracket.
- 15.14.5 Refitting or replacement is in reverse order.

15.15 HEAT EXCHANGER ACCESS

- 15.15.1 Ensure that the electrical supply is isolated.
- 15.15.2 Remove the appliance louvre door.
- 15.15.3 Remove the 4 screws and withdraw the Heat Exchanger access plate.
- 15.15.4 Remove the 4 screws and withdraw the Heat Exchanger Cover plate.
- 15.15.5 Remove the Heat Exchanger 'U' baffle.
- 15.15.6 Refitting is in reverse order.

16. DEFECT DIAGNOSIS

16.1 IMPORTANT: If an electrical defect occurs after installation of the appliance; preliminary earth continuity, polarity, and resistance to earth checks should be carried out with a multimeter. On completion of any maintenance/fault-finding task that has required the breaking and remaking of electrical connections, then checks of continuity, polarity, and resistance to earth must be repeated.

16.2 WARNINGS

16.2.1 When purging or checking gas supplies, ensure that ventilation to the room or cupboard is adequate, and that all naked lights are extinguished.

16.2.2 SYSTEM E-T models

- a. When carrying out any electrical testing, a test meter MUST be used, since low resistance test devices can cause damage to the Electronics module.
- b. Before commencing defect diagnosis, ensure that the Thermista-stat is set to maximum, mains supply is 'ON' and the time control is at an 'ON' position.
- c. Care is to be taken during the replacement and handling of electronic assemblies, (i.e., electronic panel, airflow sensor or Thermista-stat). It is not practical to rectify defects on these assemblies, except at the manufacturer, and any attempt to do so may render the guarantee or factory replacement arrangement invalid.

DEFECT DIAGNOSIS				
ITEM	SYMPTOM	POSSIBLE CAUSE	REMEDY	
1	Pilot will not light.	No gas supply to heater.	Check for gas at inlet pressure test point on Multifunctional Control.	
		Gas supply pipe not purged.	Purge gas supply pipe in accordance with BS 6891.	
		Pilot orifice restricted.	Clear pilot orifice or replace pilot injector.	
		Piezo system faulty.	Check igniter, lead, and electrode.	
		Excessive gas supply pressure.	Check that mains gas pressure is 20mbar, and reduce if necessary	
2	Pilot lights but goes out on releasing START	Connection between thermo couple and Multifunctional button during initial light-up, or after normal operation.	Check connection is secure.	
		Faulty Multifunctional Control	Control not secure.	
		Faulty Thermocouple.	Replace Thermocouple	
3	Main burner operating intermittently with fan running	Gas rate or burner pressure setting high	Check gas rate and burner pressure setting	
		Temperature rise excessive	Adjust fan speed or gas rate accordingly.	
		Air filter or return air path restricted	Check filter is clean and air path is clear	
		Excessive number of outlets closed	Open additional outlets	
		Spillage of flue gases.	Carry out spillage test and rectify.	
		Spillage monitor device (TTB) faulty	Replace Spillage device (TTB)	
SYSTEM E-T	4	Incorrect operation of fan or main burner.	Fault related to SYSTEM E-T Control system (refer to pages 17-21)	Consult diagnostic chart and follow recommended procedure.

BASIC MODELS	5	Pilot alight but main burner not igniting	Mains electrical supply not connected to heater	Check mains supply.
			Controls not demanding heat	Check that time control and room thermostat are operating correctly.
			T3.15A fuse failed.	Replace. If failure occurs again, check wiring for short circuits.
			Loose connection to room thermostat, limit switch, gas control lead, time control, or transformer.	Check connections.
			230V/24V transformer failure.	Check 24V side with test meter, if voltage missing, replace transformer.
			Faulty relay module	Check 230V at white wire from switch S5
			Multifunctional Control faulty.	Replace Multifunctional Control.
			Limit switch faulty.	Short circuit control and replace if necessary.
			Room thermostat or external wiring faulty.	Fit temporary loop in heater thermostat socket. If heater ignites, external circuit or room thermostat is faulty.
			Spillage device faulty	Check Spillage device and wiring for open circuit.
6	Main burner lights but fan fails to run after approximately 3 min.	Loose electrical connection at fan control.	Check connections.	
		Fan Delay Control faulty.	Replace.	
		Faulty fan assembly.	Replace, taking care not to damage impeller.	
		Burner pressure setting incorrect.	Check gas rate and burner pressure setting	
7	Main burner operating with intermittent fan operation.	Gas rate or burner pressure setting too low.	Check gas rate and burner pressure setting	
		Fan Delay Control faulty	Replace.	
8	Noisy operation.	Gas pressure too high.	Check burner pressure setting.	
		Noisy fan motor.	Replace fan assembly.	
		Fan speed setting too high.	Adjust fan speed.	
9	Fan runs for excessive period or operates intermittently after main burner shuts down.	Fan delay control faulty.	Replace.	

FIGURE 9. DEFECT DIAGNOSIS

16.3 The **SYSTEM E-T** module is fitted with a diagnostic light emitting diode (LED) which is visible through a hole in the module cover, as shown in Fig. 4 below. If the LED is flashing, this means that :

- 18.3.1 The fan is not connected, or
- 18.3.2 The capacitor is not connected, or
- 18.3.3 There is a short circuit in the fan supply.

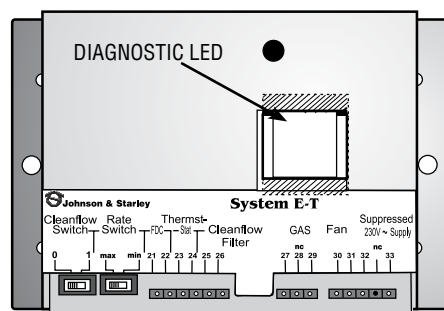

FIGURE 9. SYSTEM E-T CONTROL PANEL

17. DIMENSIONS

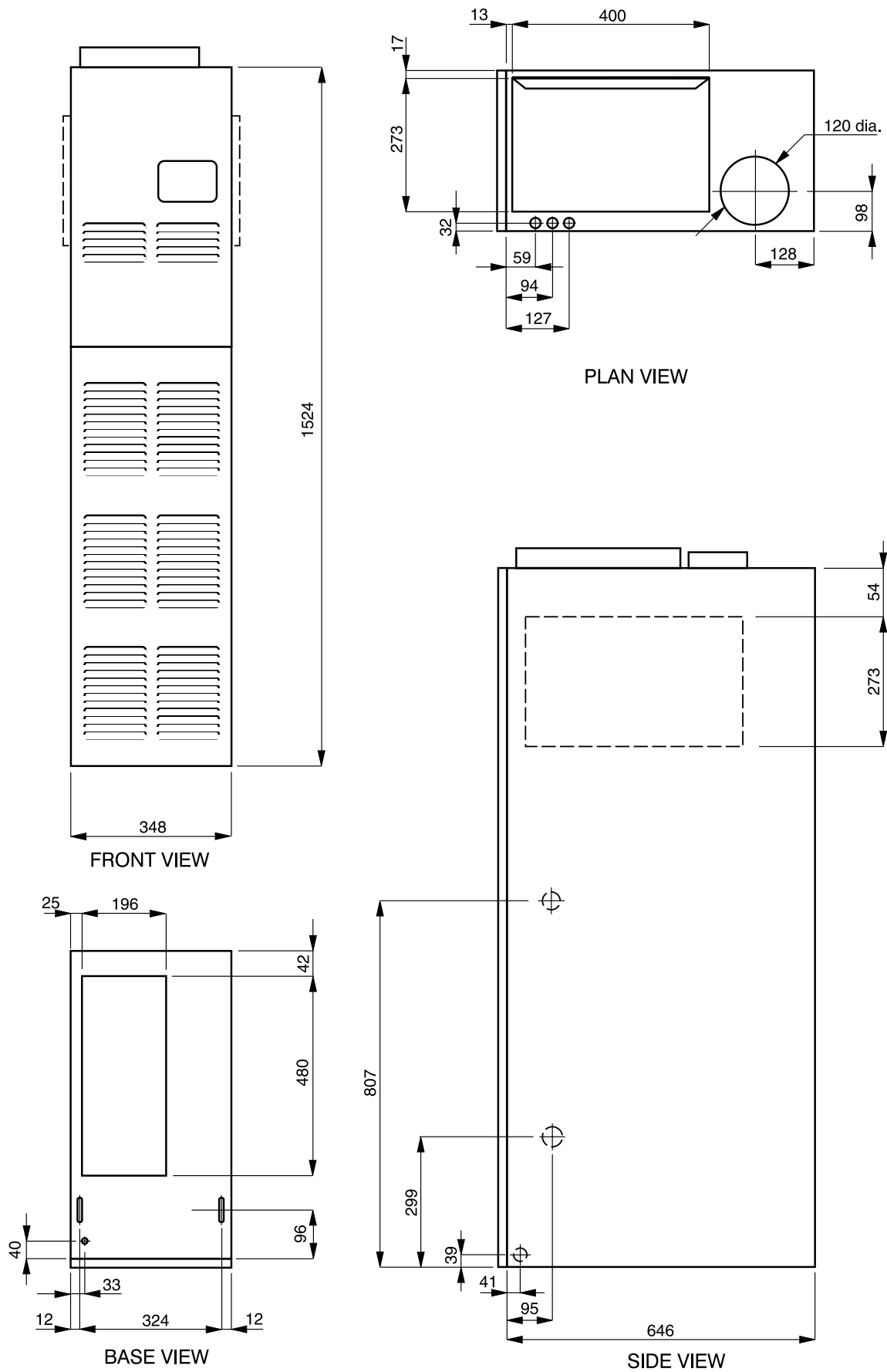
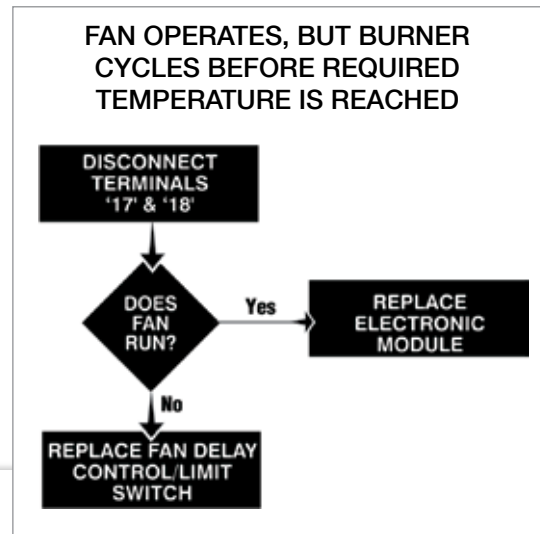
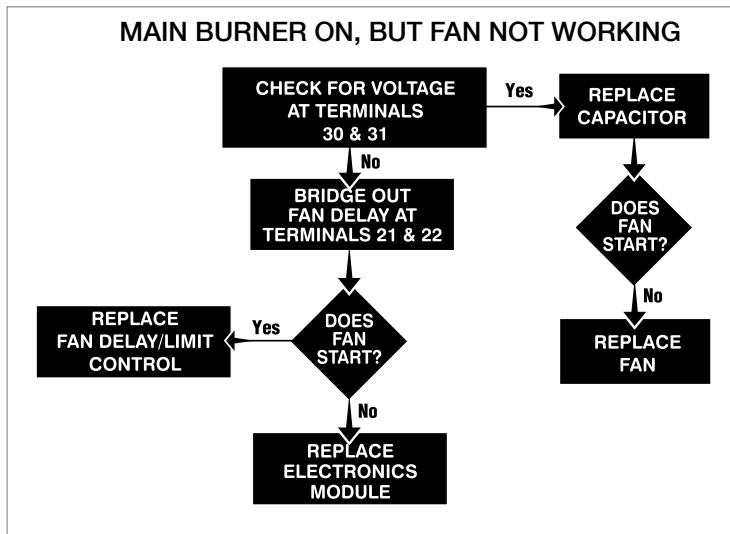
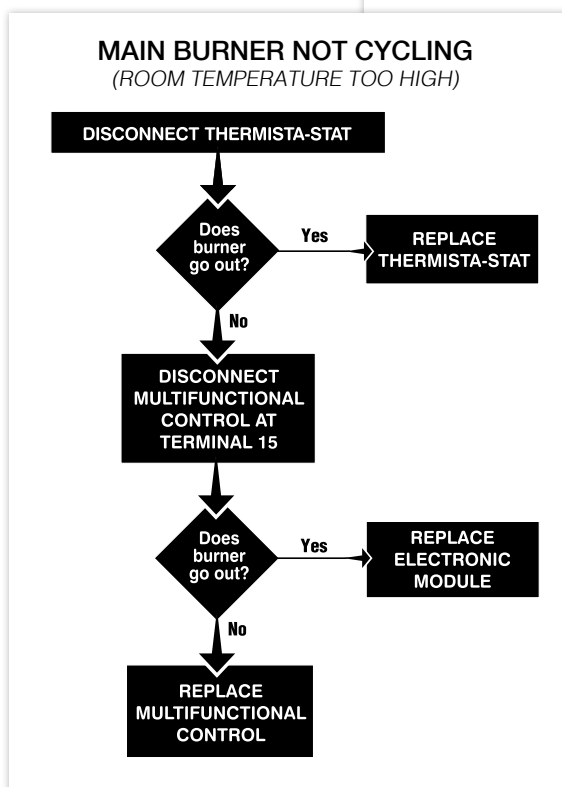
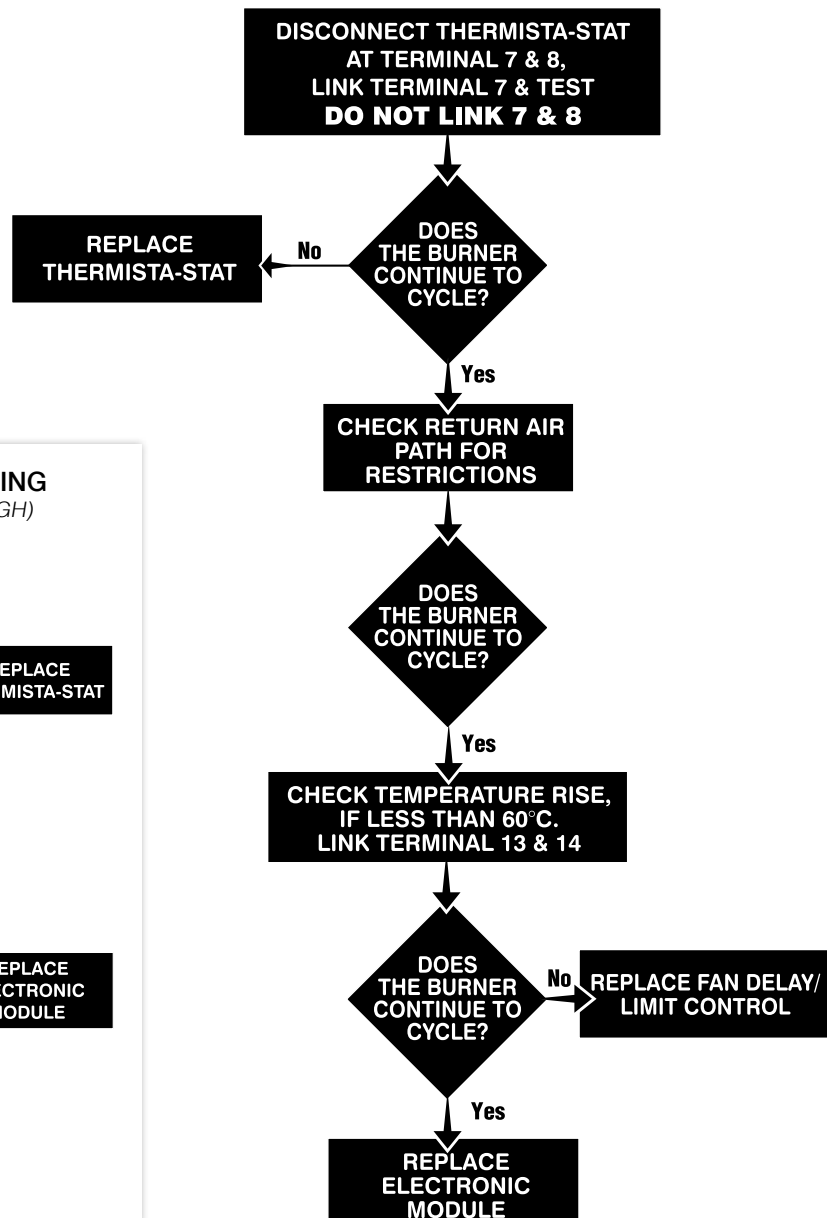

FIGURE 11. HI-SPEC J40 DIMENSIONS

18. FAULT FINDING FLOWCHARTS



FAN CONTINUES TO RUN, OR CYCLES AFTER HEATING IS TURNED OFF



MAIN BURNER NOT OPERATING

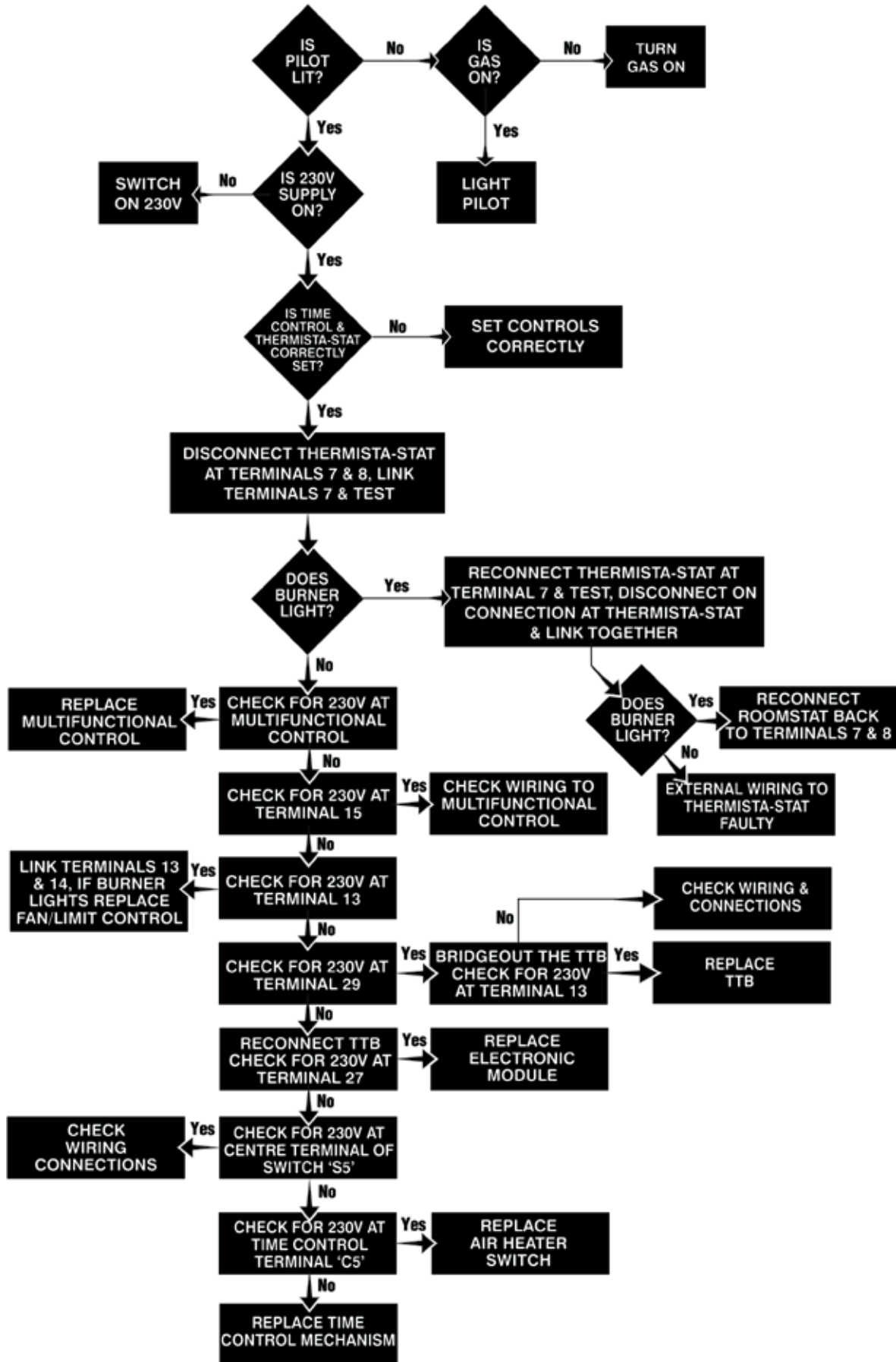

20. DEFECT DIAGNOSIS FLOWCHART

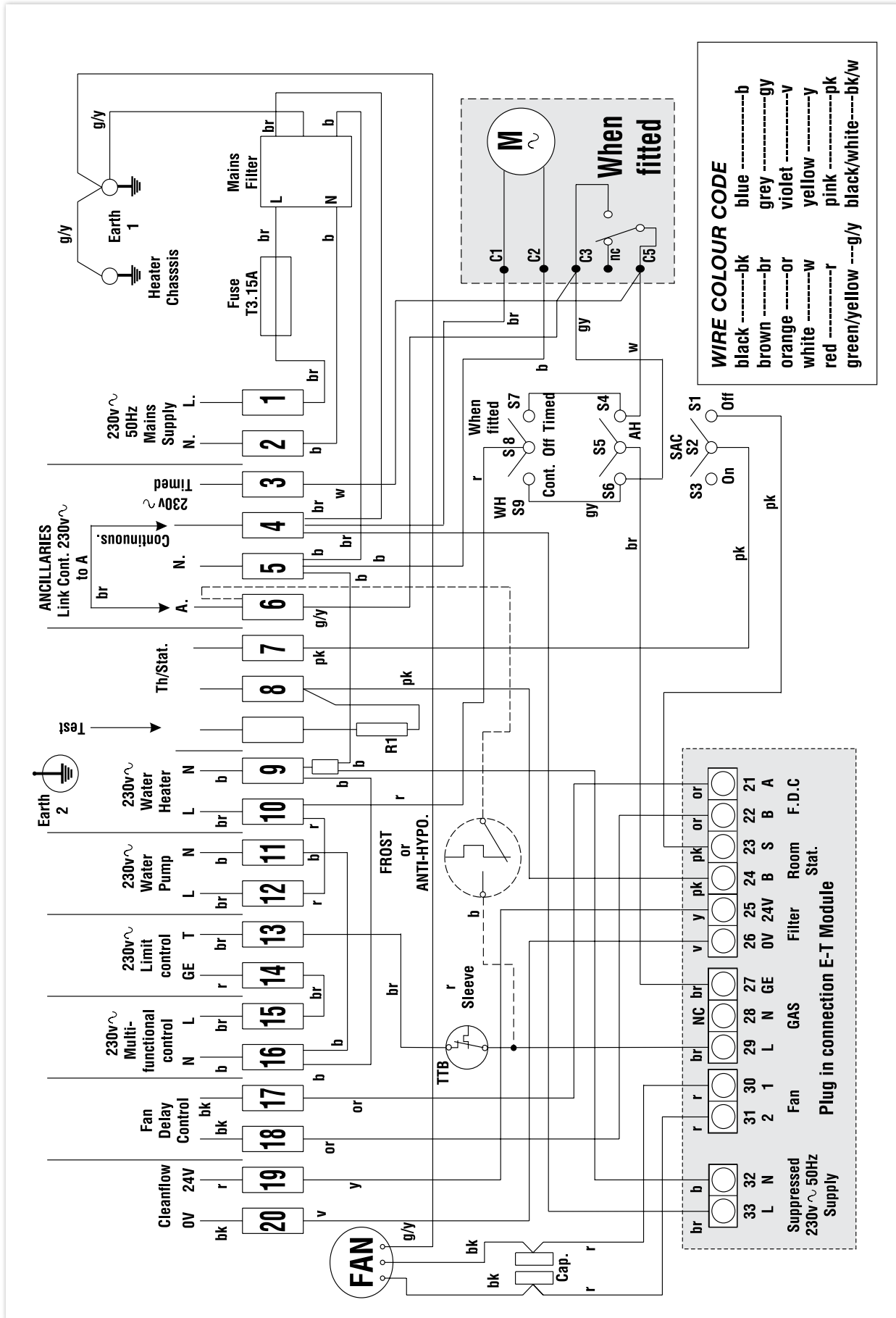

WIRE COLOUR CODE

black	-----bk	blue	-----b
brown	-----br	grey	-----gy
orange	-----or	violet	-----v
white	-----w	yellow	-----y
red	-----r	pink	-----pk
green/yellow	----g/y	black/white	----bk/w

FIGURE 12. SYSTEM E-T FUNCTIONAL DIAGRAM

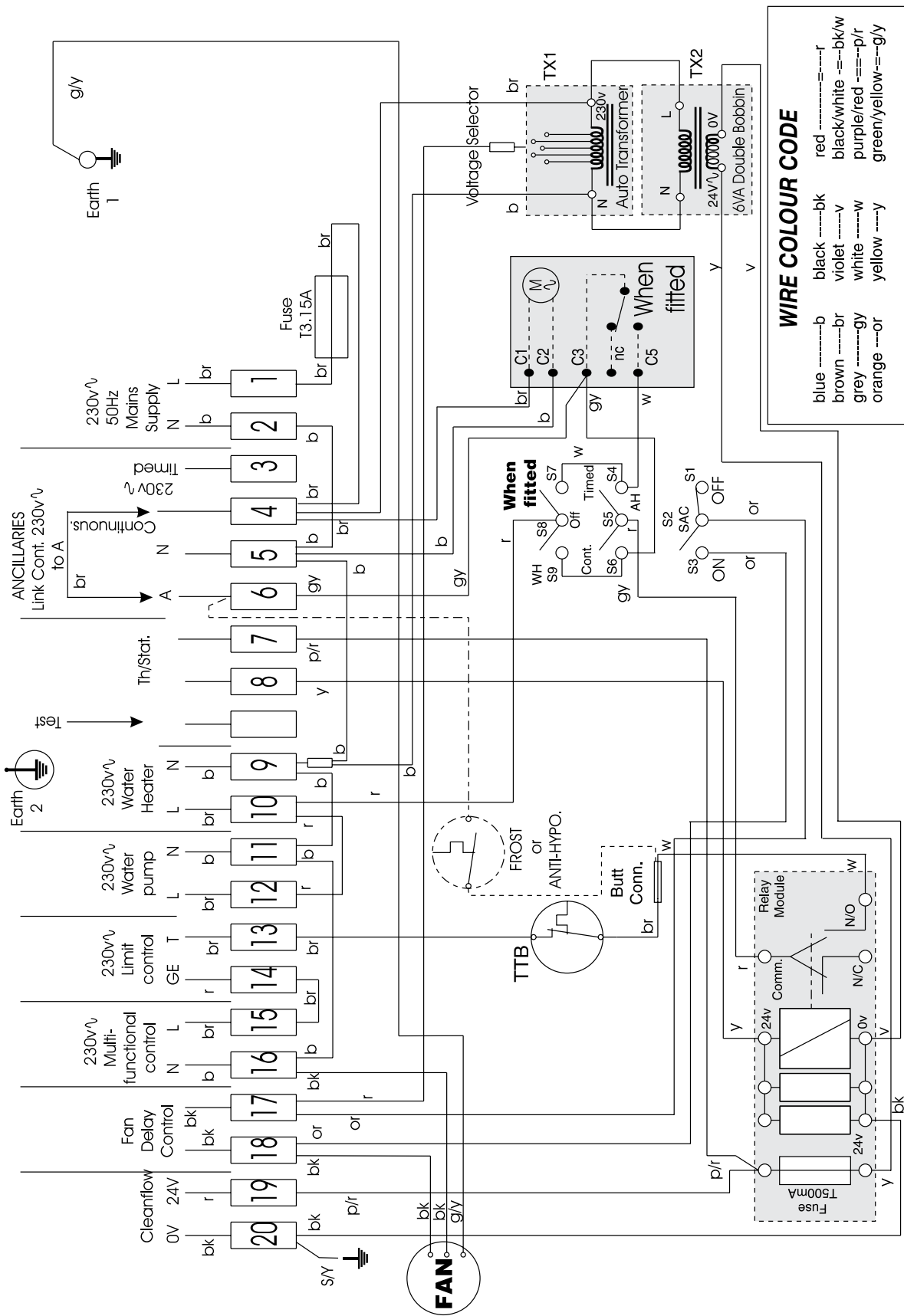

FIGURE 13. BASIC FUNCTIONAL DIAGRAM

21. LOGIC DIAGRAM

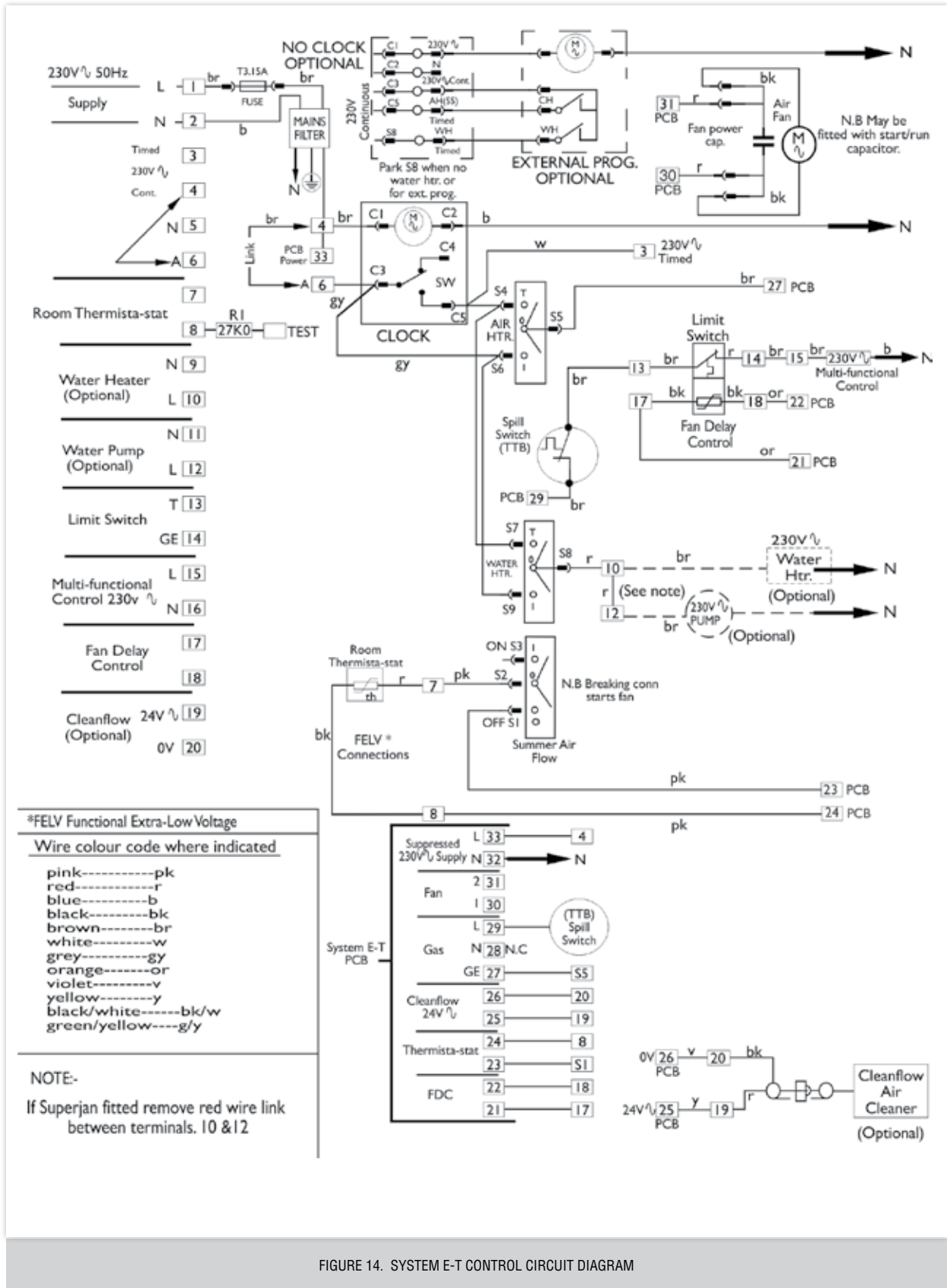

FIGURE 14. SYSTEM E-T CONTROL CIRCUIT DIAGRAM

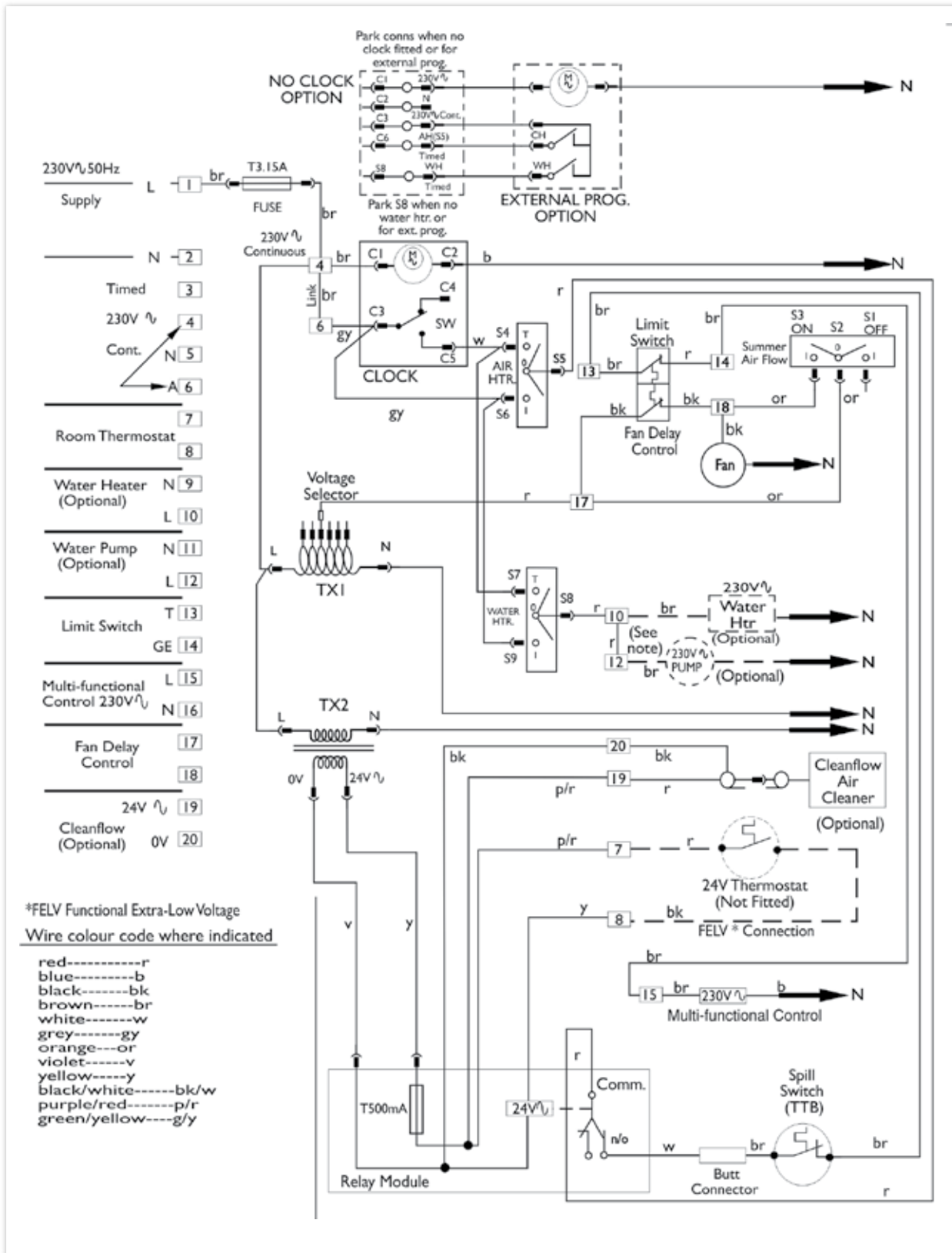

FIGURE 15. BASIC CONTROL CIRCUIT DIAGRAM

22. SORT LIST OF SPARES

	ITEM	G.C. No.	PART No.	DESCRIPTION	QTY
HI-SPEC J40	1	245 502	1000-0516580	Fan Assembly	1
	2	381 627	1000-0701140	Multifunctional Control (Honeywell)	1
	3	232 903	BOS 02061	O Ring Seal	2
	4		A432-0852000	Pilot Mounting Bracket	1
	5	173 096	1000-0704810	Pilot Burner Assembly	1
	6	381 712	1000-0705140	Pilot Injector	1
	7		S01496	Pilot Feed Pipe Kit	1
	8	395 67	1000-0701800	Hook Nut 4mm	1
	9	386 775	1000-0701790	Hook Olive 4mm	1
	10	386 775	BOS 01970	Igniter Electrode	1
	11	387 819	BOS 02394	Igniter Lead	1
	12	381 626	1000-0704830	Thermocouple	1
	13	382 775	1000-0701810	Shear Off 4mm	1
	14	244 898	BOS 02406	Electrode Retaining Nut	1
	15	378 466	BOS 02031	Time Control	1
	16	245 526	A432-0760000	Burner and Controls Assembly	1
	17	245 526	A4300/0751	Main Burner Arm	1
	18	E00 409	1000-0700270	Main Injector (Bray 23/1050)	1
	19	395 945	1000-0700570	Piezo Unit (High Energy)	1
	20	245 509	1000-0513820	Fuse T3.15A anti-surge	1
	21		A432-0182000	Filter Tray	1
	22	364 835	S00832	Solenoid Valve	1
	23		A4300/0300WE	Heat Exchanger	1
	24	245 542	1000-0515970	Capacitor 15 uF	1
	25	245 500	1000-0516010	Spillage Monitor Device (TTB) up to & including Serial No: 16001719	1
	26	E83-211	1000-0521880	Spillage Monitor Device (TTB) from Serial No: 16001720	1
	27		A432-0161000	Lower Cabinet Door	1
SYSTEM E-T	28	245 513	ET 004	Electronic Panel Assembly with daughter board	1
	29	245 514	1000-0515620	Thermista-stat	1
	30	245 516	1000-0516370	Fan Delay Control/Limit Switch	1
	31	E05 328	1000-0515090	Mains Filter	1
	32		A432-0157000	Fan Chamber Door	1
BASIC MODEL	33	245 524	1000-0501000	Electrical Panel Assembly	1
	34	245 521	1000-0516360	Fan Delay Control/Limit Switch	1
	35	245 523	1000-0516540	Transformer Fan Speed	1
	36	245 525	1000-0515730	Transformer 24 volt	1
	37	245 413	1000-0511760	Relay Module	1
	38	245 423	1000-0502240	Fuse T500mA anti-surge	1
	39		A432-0156000	Fan Chamber Door	1

23. EXPLODED DIAGRAM

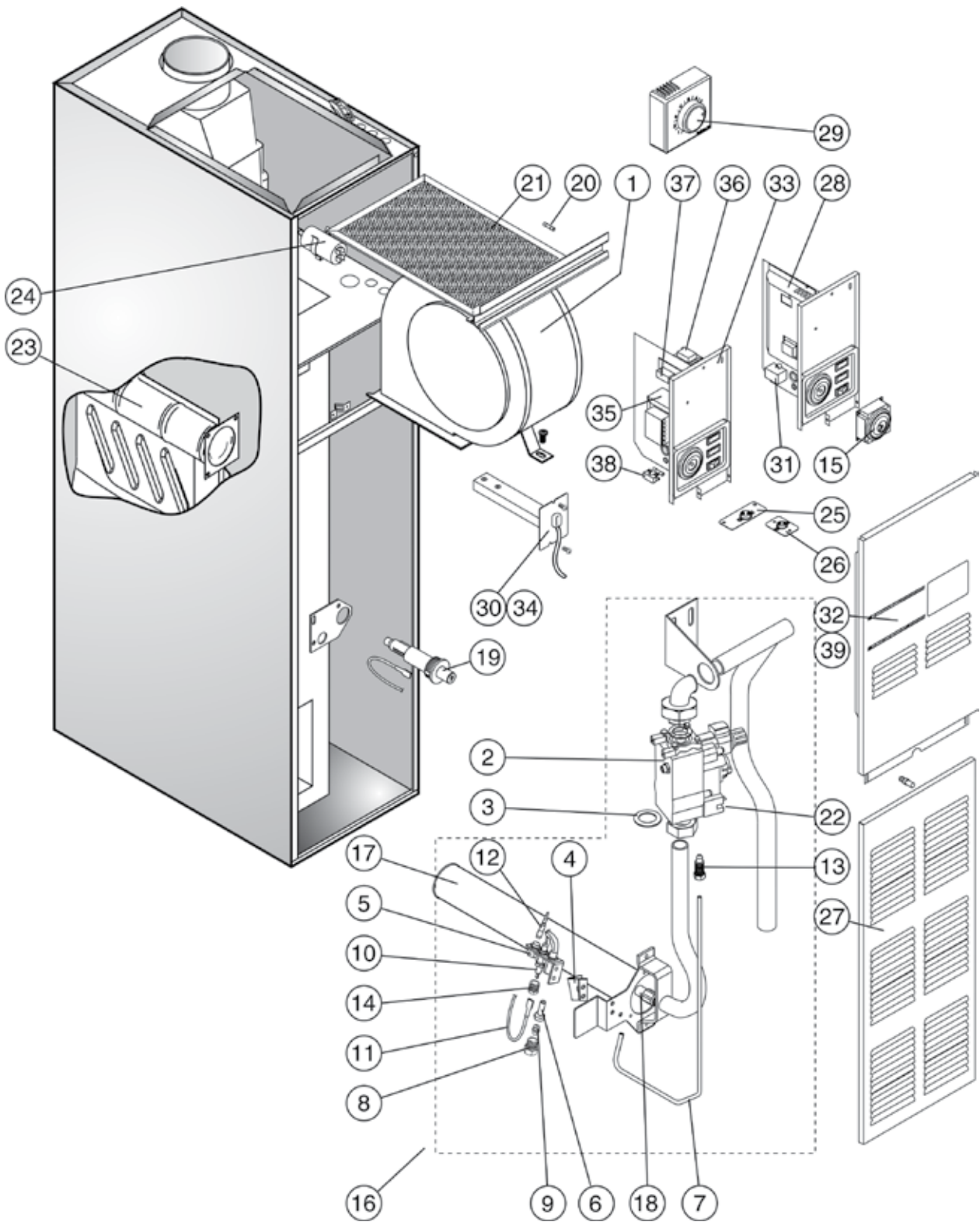

FIGURE 16. HI-SPEC J40 EXPLODED DIAGRAM

CONDENSING WARM AIR HEATING AND WATER HEATING COMMISSIONING CHECKLIST

This Commissioning Checklist is to be completed in full by the competent person who commissioned the wsnn air unit and associated equipment as a means of demonstrating compliance with the appropriate Building Regulations and then handed to the customer to keep for future reference

Failure to Install and commission this equipment to the manufacturer's instructions may Invalidate the warranty but does not affect statutory rights.

Customer name:										Telephone number:														
Address:																								
Warm Air Unit Make and Model:																								
Warm Air Unit Serial Number:																								
Commissioned by (PRINT NAME):										Gas safe register number:														
Company name:										Telephone number:														
Company address:																								
										Commissioning date:														
To be completed by the customer on receipt of a Building Regulations Compliance Certificate*:																								
Building Regulations Notification Number (if applicable)																								
CONTROLS (tick the appropriate boxes)																								
Time and temperature control to heating										Room thermostat and programmer/timer					Programmable Roomstat									
										Load/weather compensation					Optimum start control									
Heating zone control										Fitted					Not required									
WARM AIR HEATER																								
Has the system been balanced in accordance with the heater manufacture's instructions?															Yes				No					
Was an anemometer used?															Yes				No					
Have balancing dampers been fitted?															Yes				No					
WARM AIR HEATING: measure and record:																								
Bumer operating pressure (at maximum rate)																				mbar				
Heat input																				kW				
Temperature difference between return air inlet and nearest outlet																				°C				
WATER HEATING: (If fitted)																								
Water inlet temperature																				°C				
Water outlet temperature																				°C				
CONDENSATE																								
The condensate drain has been installed in accordance with the manufacture's instructions and/or BS 5546/BS6798																				Yes				
INSTALLATION																								
The heating and hot water system complies with the appropriate Building Regulations																				Yes				
The system and associated products have been installed and commissioned in accordance with the manufacturers instructions																				Yes				
The efficient operation of system and its controls have been demonstrated to and understood by the customer																				Yes				
The manufacturer's literature, including Benchmark Checklist and Service Record, has been explained and left with the customer																				Yes				
Commissioning Engineer's Signature																								
Customer's Signature																								
(To confirm satisfactory demonstration and receipt of manufacturer's literature)																								

*All installations in England and Wales must be notified to Local Authority Building Control (LABC) either directly or through a Competent Persons Scheme. A Building Regulations Compliance Certificate will then be issued to the customer.



SERVICE RECORD

It is recommended that your heating system is serviced regularly and that the appropriate Service Interval Record is completed.

Service Provider

Before completing the appropriate Service Record below, please ensure you have carried out the service as described in the manufacturer's instructions. Always use the manufacturer's specified spare part when replacing controls.

SERVICE 01		Date:	
Engineer name:			
Company name:			
Telephone No:			
Gas safe register No:			
Record:	At max. rate:	CO	ppm AND CO ₂ %
	At min. rate: (Where Possible)	CO	ppm AND CO ₂ %
Comments:			
Signature			

SERVICE 02		Date:	
Engineer name:			
Company name:			
Telephone No:			
Gas safe register No:			
Record:	At max. rate:	CO	ppm AND CO ₂ %
	At min. rate: (Where Possible)	CO	ppm AND CO ₂ %
Comments:			
Signature			

SERVICE 03		Date:	
Engineer name:			
Company name:			
Telephone No:			
Gas safe register No:			
Record:	At max. rate:	CO	ppm AND CO ₂ %
	At min. rate: (Where Possible)	CO	ppm AND CO ₂ %
Comments:			
Signature			

SERVICE 04		Date:	
Engineer name:			
Company name:			
Telephone No:			
Gas safe register No:			
Record:	At max. rate:	CO	ppm AND CO ₂ %
	At min. rate: (Where Possible)	CO	ppm AND CO ₂ %
Comments:			
Signature			

SERVICE 05		Date:	
Engineer name:			
Company name:			
Telephone No:			
Gas safe register No:			
Record:	At max. rate:	CO	ppm AND CO ₂ %
	At min. rate: (Where Possible)	CO	ppm AND CO ₂ %
Comments:			
Signature			

SERVICE 06		Date:	
Engineer name:			
Company name:			
Telephone No:			
Gas safe register No:			
Record:	At max. rate:	CO	ppm AND CO ₂ %
	At min. rate: (Where Possible)	CO	ppm AND CO ₂ %
Comments:			
Signature			

SERVICE 07		Date:	
Engineer name:			
Company name:			
Telephone No:			
Gas safe register No:			
Record:	At max. rate:	CO	ppm AND CO ₂ %
	At min. rate: (Where Possible)	CO	ppm AND CO ₂ %
Comments:			
Signature			

SERVICE 08		Date:	
Engineer name:			
Company name:			
Telephone No:			
Gas safe register No:			
Record:	At max. rate:	CO	ppm AND CO ₂ %
	At min. rate: (Where Possible)	CO	ppm AND CO ₂ %
Comments:			
Signature			

SERVICE 09		Date:	
Engineer name:			
Company name:			
Telephone No:			
Gas safe register No:			
Record:	At max. rate:	CO	ppm AND CO ₂ %
	At min. rate: (Where Possible)	CO	ppm AND CO ₂ %
Comments:			
Signature			

SERVICE 10		Date:	
Engineer name:			
Company name:			
Telephone No:			
Gas safe register No:			
Record:	At max. rate:	CO	ppm AND CO ₂ %
	At min. rate: (Where Possible)	CO	ppm AND CO ₂ %
Comments:			
Signature			

*All installations in England and Wales must be notified to Local Authority Building Control (LABC) either directly or through a Competent Persons Scheme. A Building Regulations Compliance Certificate will then be issued to the customer.





sustainable solutions
under one roof

Johnson & Starley Ltd

Rhosili Road, Brackmills,
Northampton NN4 7LZ

sales@johnsonandstarley.co.uk

marketing@johnsonandstarley.co.uk

Reception/Customer Service

01604 762881

Fax

01604 767408

