



These instructions are to be left with the User or adjacent to the Gas Meter

HI-SPEC J32P and HI-SPEC J32RP
WARM AIR HEATERS
with Conventional Control
INSTALLATION, COMMISSIONING & SERVICING INSTRUCTIONS
G.C. No 42 451 07 HI-SPEC J32P
G.C. No 42 451 08 HI-SPEC J32RP

Publication No. ZZ 982/7
February 2007

These appliances have been tested and certified by B G Technology for use with PROPANE gas G31.

Note: If a HIJAN 6P circulator is fitted, the relevant Installation, Commissioning and Servicing instructions provided with that appliance must also be observed.

1. BRIEF DESCRIPTION

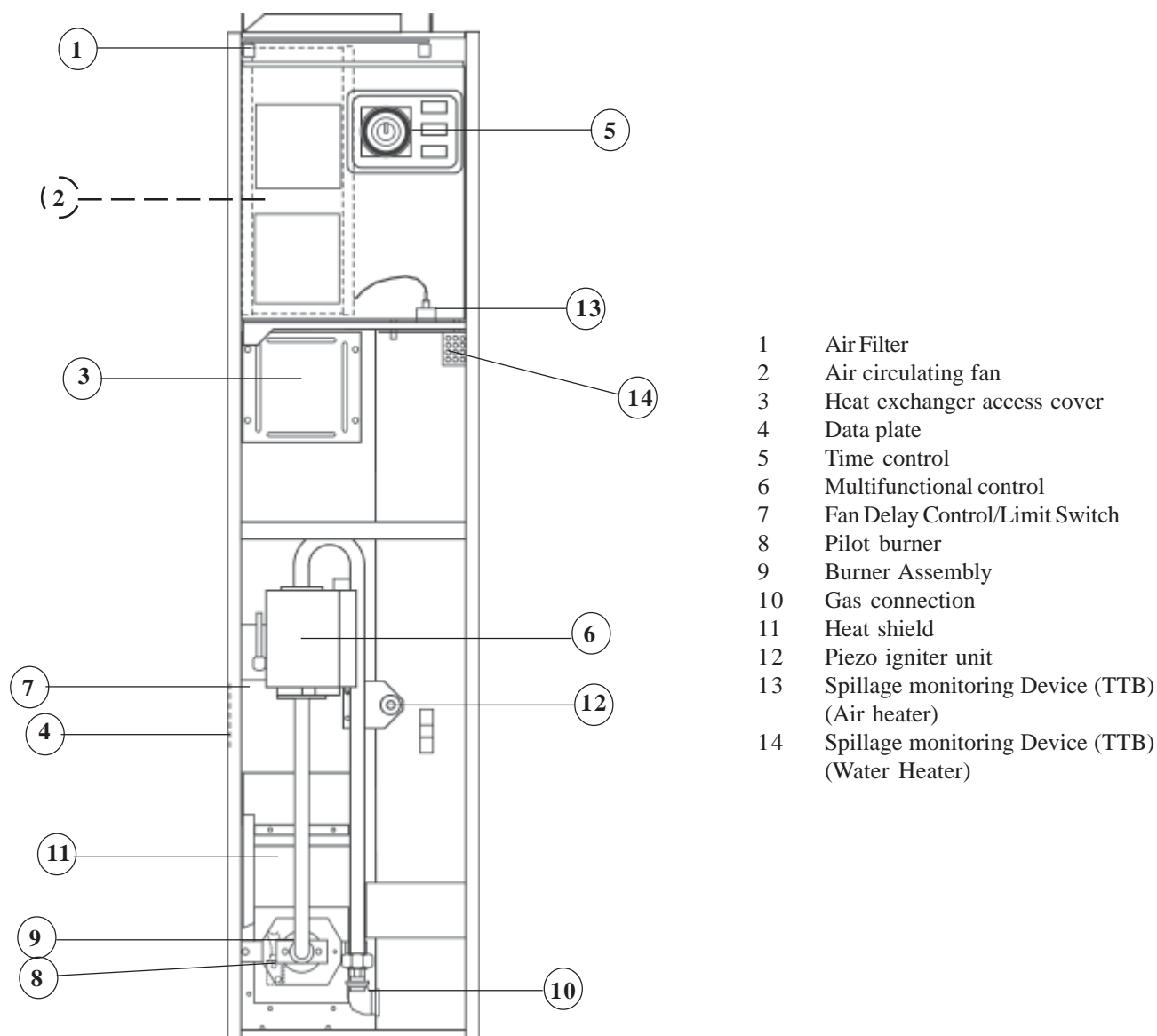

Fig. 1

- 1.1 HI-SPEC J32P is an open-flued, fan assisted downflow, ducted warm air heater, supplied with conventional control. A HIJAN 6P circulator is available as an option. HI-SPEC J32RP, which has an integral rear rising duct is also available as an option. A Spillage Monitoring Device (TTB) is fitted which senses the temperature in the draught diverter, and shuts down the appliance when this temperature rises due to the presence of flue gases.
- 1.2 The Air heater output is 8.30kW (29.88MJ/h, 28,320Btu/h) . “Summer air circulation” of unheated air is available by manual selection (see User’s Instructions). HIJAN 6P output is 3.56kW (12.8MJ/h, 12,150Btu/h).

THIS APPLIANCE CONFORMS TO BS EN 55014

Installation shall be in accordance with the current editions of:-

Building Standards (Scotland) (Consolidation) Regulations
Building Regulations
Gas Safety (Installation and Use) Regulations (as amended)
BS 7671 Institute of Electrical Engineers (I.E.E.) Wiring Regulations
BS 5482 Pt. 1 Domestic Butane- and Propane-gas-burning installations.
BS 5440 Pt. 1 (Flues for Gas Appliances)
BS 5440 Pt. 2 (Air Supply for Gas Appliances)
BS 5864 Installation of Gas Fired Ducted Air Heaters
British System Design Manual "Gas Fired Warm Air Heating"
Model and Local Authority Bye-laws
BS 5546 Installation of Domestic Hot Water Supplies.

IMPORTANT: STATUTE LAW DEFINES THAT ALL GAS APPLIANCES MUST BE INSTALLED BY COMPETENT PERSONS, (i.e. CORGI REGISTERED INSTALLERS) IN ACCORDANCE WITH THE GAS SAFETY (INSTALLATION AND USE) REGULATIONS (CURRENT EDITION). FAILURE TO COMPLY WITH THESE REGULATIONS MAY LEAD TO PROSECUTION.

2. HEATER COMPARTMENT AND CLEARANCES (See BS 5864)

- 2.1 **IMPORTANT:** If the heater is to be fitted to an existing base duct (warm air plenum), always ensure that installation is carried out such that the rear left hand corner of the heater is aligned with the rear left hand corner of the base duct, so that any overhang or blanking off will be at the front and/or right hand side. In any event, blanking plates must be mechanically secured and all joints sealed.
- 2.2 When the heater is fitted into a compartment, a minimum clearance from the compartment walls of 3mm at the sides and rear, and 75mm (3 in) at the front must be left. Consideration should also be given to the space required for the removal and replacement of the filter tray and the entry of the gas, water and electrical supplies. If gas and /or water connections are made from a side entry, a minimum clearance of 75mm is required at that side.
- 2.3 For service access, a minimum of 450mm (18ins) is required at the front of the heater. Space must also be allowed, in a compartment installation, to permit the removal of the heater. The clearance between the appliance and the compartment should be not less than 75mm (3 in). However, if clearances are less than 75mm, the internal surface of the compartment must be lined with non-combustible material. The compartment must be of a fixed rigid structure.
- 2.4 In airing cupboard installations, the part used as the air heater compartment must comply with the relevant section of BS5864 and must be completely separated by either a non-combustible partition or a perforated metal partition with the perforations not exceeding 13mm (1/2in). The secondary flue must be a tight fit where it passes through the partition and must be suitably protected (see BS5440:Part 1).
- 2.5 In free-standing installations, (see instructions packed with TC32 or TC32R Top Closure Kit), only one or two walls will be in close proximity to the air heater; these must be non-combustible.
- 2.6 If the Air Heater is to be installed onto a combustible surface, a suitable base tray is required (BT32 for J32 model appliances) is required. However, when a base duct is used, this provides sufficient protection for combustible material and no further insulation is required.
- 2.7 For Slot Fix applications (see instructions packed with the Slot Fix Kit), it is important to ensure that the draught diverter relief is maintained on both sides of the application.

3. VENTILATION AND COMBUSTION AIR

- 3.1 The room or internal space in which the heater is installed requires a permanent air vent of minimum effective area 41cm² (6in²). The air vent should be either direct to outside air or to an adjacent room or internal space (other than a toilet or bathroom) that itself has an equivalent air vent direct to outside.
- 3.2 Combustion air may be introduced, via a 100mm (4in) nominal bore pipe, connected to a return air duct or plenum from a ventilated area and fitted with a lockable damper. The damper should be adjusted to control combustion airflow to 0.0099m³/s (21cfm), (i.e. 1.26m/s [250ft/min] velocity in a 100mm [4in] bore pipe). If this arrangement is used, a non-closeable warm air register **MUST** be provided in the same area as the front of the air heater or heater compartment if a return air grille is not located in that area.
- 3.3 When installed in a compartment, two permanent ventilation openings into the compartment are required, one at high level and one at low level, both communicating either directly with outside air or with a ventilated room or space. The minimum effective areas specified in Table 1 are related to the rated heat input of the Air Heater, and assuming that a HIJAN 6P circulator is fitted.
- 3.4 If any room or area from which air is drawn for ventilation or combustion contains an extract fan, the permanent vents must be sized to ensure that the operation of the appliance(s) at full rate is/are not adversely affected. A spillage test as specified in sub-para 6.8 (Safety Checks) is carried out and any remedial work undertaken.

VENTILATED FROM INSIDE BUILDING	Low level grille	288cm ² (44in ²)
	High level grille	144cm ² (22in ²)
VENTILATED FROM OUTSIDE BUILDING	Low level grille	144cm ² (22in ²)
	High level grille	72cm ² (11in ²)

Table 1: Minimum Effective Areas

4. DUCT SYSTEM

(See British Design Manual - Gas fired Warm Air Heating)

4.1 RETURN AIR

- 4.1.1 All return air shall be POSITIVELY ducted from outside the compartment to the top of the unit via a return air duct, or if appropriate, using a J & S Side Return Air Kit, and mechanically secured. It is recommended that the return air duct be not routed directly from the main living area, but from a convenient central area serving the remainder of the dwelling.
- 4.1.2 The return air system should be constructed of fire-resistant material. The flue shall not be run through an area serving as a return air path. It is extremely important that the correct size of return air grilles and ducting is used. For heaters on maximum output the return air duct size should not be less than the equivalent of 250mm x 200mm (10" x 8"). If flexible duct is used the duct diameter should not be less than 300mm (12") dia. The return air grille should have a free area of not less than 860cm² (137in²).
- 4.1.3 An adequate and unobstructed return air path is essential from areas not served by a directly ducted return and to which warm air is delivered. All such rooms should be fitted with relief grilles which have a free area of 0.0088m²/kW (1in²/250Btu/h) of heat supplied to the room. The only exceptions are kitchens, bathrooms and WC.'s.
- 4.1.4 The return air duct should allow for ease of removal for access to the flue.
- 4.1.5 All duct work in the room or internal space in which the heater is installed shall be mechanically secured, and sealed with ducting tape.

4.2 WARM DELIVERED AIR

- 4.2.1 All duct work, including riser ducts, should be fully insulated with 50mm (2in) fibreglass or similar. If short extended duct runs are taken below floor level these should be similarly insulated, and in addition wrapped with a sound vapour proof barrier, and protected from crushing.
- 4.2.2 The duct system should be carefully designed (as given in the guidelines in the British System Design Manual) to suit the needs of its specific heating requirements and building layout. The type of duct system, (i.e. radial/extended plenum/stepped) should be installed using the least number of fittings to minimise airflow resistance. The base duct, which equalises the air pressure to supply ducts, shall be constructed to support the weight of the heater, which shall be secured to the plenum with screws on at least two sides, and sealed using self-adhesive foam strip, ducting tape or sealing compound. All ducting and blanking plates shall be mechanically secured and sealed.

5. INSTALLATION REQUIREMENTS

Note: For circulator Installation Instructions, refer to the relevant instructions provided with the circulator.

5.1 FLUES (see British Standards BS 5440 Pt. 1 Flues)

- 5.1.1 All joints shall be soundly sealed.
- 5.1.2 The flue should be kept as short and warm as possible.
- 5.1.3 Sufficient support brackets shall be installed to bear the weight of the total flue system.
- 5.1.4 The spigot connection of the heater draught diverter will accept internally the spigot end of a non-asbestos flue to BS 567 or twin wall metal flue to BS 715 of nominal 100mm (4in) diameter.
- 5.1.5 A split collar should be fitted to provide for flue maintenance or inspection.
- 5.1.6 The flue shall be in accordance with the Building Regulations and British Gas Materials and Installations specification (3rd edition) with regard to clearance and shielding from combustible materials.
- 5.1.7 All materials shall be in accordance with Building Regulations requirements.

- 5.1.8 The flue should run as vertically as possible. Horizontal runs should be avoided if at all possible and any directional change should be as gentle as possible. If there is any doubt about the flue configuration, the equivalent flue height should be determined (see 5.1.10).
- 5.1.9 If the appliance to be fitted is a replacement, the old appliance should be checked for signs of spillage prior to commencement of the installation and appropriate action taken, (i.e. check flue system and renew as necessary).
- 5.1.10 It is recommended that at least 600mm of vertical flue should be provided above the appliance (for new installations this shall be incorporated into the flue design). However, when carrying out replacement installations, an existing flue system may be encountered, where the vertical flue above the appliance to the first bend is less than 600mm. In the first instance, the installer must judge whether this distance can be achieved practicably by some means. Where this is not practicable, the existing flue system may be used, providing there is no evidence of spillage from the old appliance (see 5.1.9 above). Every effort must be made, however, to ensure that the existing flue complies in every other way to BS 5440 Part 1, including the visual inspection, flue flow and spillage test described in 4.3.2 of the above standard. Flue configurations may be assessed in terms of equivalent vertical height - details are given below. For air heaters, the minimum equivalent vertical height is 1 metre. The installer must make a judgement based on his knowledge and experience and the examination and testing described above as to whether an existing flue system can be used.

Note: Ventilation of the compartment, room or internal space in which the appliance is to be installed must be checked for compliance with the requirements of BS 5440 Part 2 (Ref. Section 3 of these instructions) and upgraded as necessary.

5.1.11 **Calculation method for flue sizing: (from BS 5440: Part 1, Appendix A)**

- a. This appendix provides a procedure for estimating whether a given flue design is likely to ensure full clearance of combustion products.
- b. The procedure is based on calculating the ‘equivalent height’ of the flue under consideration, (i.e. that height of the straight vertical circular flue pipe of specific size which will produce the same flow rate as the flue under consideration). The equivalent height is calculated from the formula:

$$H_e = H_a \times \frac{(K_i + K_o)_e}{(K_i + K_o)_a - K_e H_a + \text{Sum K}}$$

where:

H_e is the height of the equivalent flue;

H_a is the vertical height of the actual or proposed flue;

K_i is the inlet resistance of the flue;

K_o is the outlet resistance from the flue;

subscript e refers to the equivalent flue diameter;

subscript a refers to the actual or proposed flue diameter;

K_e is the resistance per unit length of the equivalent flue;

Sum K is the resistance (other than the inlet and outlet resistance) of the actual or proposed flue.

Note: K and Sum K are obtained from Table 2. K_o and K_i are obtained from Table 3.

- c. Table 2 gives resistance factors for common flue components for use in the formula. Table 3 contains the appropriate inlet and outlet flue resistances, (**the flue is likely to be satisfactory of its equivalent height exceeds 1m**).

Component	Internal Size (mm)	Resistance Factor	Component	Internal Size (mm)	Resistance Factor
Flue Blocks	197 x 67	0.85 per meter	135° Bend	100 mm pipe	0.61 per
	231 x 65	0.65 run		125 mm pipe	0.25 fitting
	317 x 63	0.35		150 mm pipe	0.12
	140 x 102	0.60		197 x 67	0.30
	200 x 75	0.60		231 x 65	0.22
	183 x 90	0.45		317 x 63	0.13
Pipe	100	0.78	Raking block	Any	0.30 per block
	125	0.25	Adaptor block	Any	0.50
	150	0.12			
Chimney	213 x 213	0.02	Terminal	100 mm ridge	2.5
90° Bend	100 mm pipe	1.22 per		125 mm ridge	1.0
	125 mm pipe	0.50 fitting		150 mm ridge	0.48
	150 mm pipe	0.24		100 mm GCI	0.6
				125 mm GCI	0.25
				150 mm GCI	0.12

Table 2
Resistance factors for use in calculating equivalent heights

Appliance	Inlet Resistance (K _i)	Flue	Outlet Resistance (K _o)
100 mm dia spigot	2.5	100 mm flue	2.5
125 mm dia spigot	1.0	125 mm flue	1.0
150 mm dia spigot	0.48	150 mm flue	0.48

Table 3
Inlet and outlet resistance

d. **Worked Calculation Example:**

A warm air unit with a 100 mm diameter flue spigot, fitted with a pre-fabricated flue system leading to a ridge tile in the loft (refer Fig. 2):

From table 3:

K _{ia}	Inlet resistance of actual flue	= 2.5
K _{oa}	Outlet resistance of actual flue	= 2.5
K _{ie}	Inlet resistance of equivalent flue	= 2.5
K _{oe}	Outlet resistance of the actual flue	= 2.5

From table 2:

Other resistances of actual flue:

Terminal	= 2.5
Pipe bend (2 x 0.61)	= 1.22
Pipe (4 x 1m @ 0.78)	= 3.12
(5 x 0.3m @ 0.78)	= 1.17

Sum K = 8.01

Equivalent height :

From the formula

$$H_e = 6.2 \times \frac{(2.5 + 2.5)}{(2.5 + 2.5) - (0.78 \times 6.2) + 8.01}$$

H_e = 3.793 This flue exceeds 1.0m equivalent height and is therefore satisfactory.

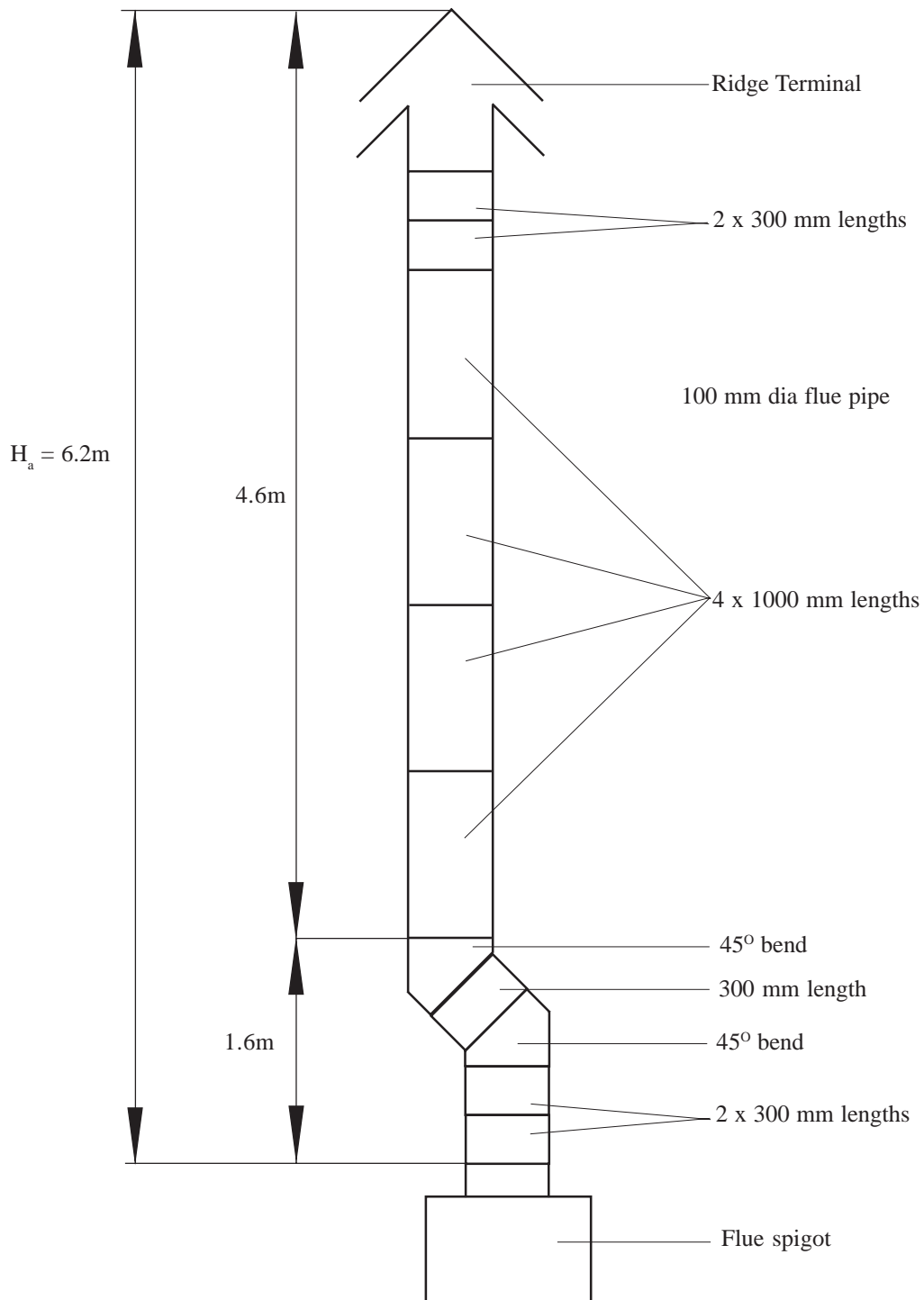

Fig. 2
Worked example of equivalent flue height

- 5.1.12 Special consideration must be given to external flues with a view to prevention of condensation and weathering problems.
- 5.1.13 An approved terminal should always be used; a ridge terminal or “GC1” terminal is specifically recommended. The latter should be positioned in a free air space where it is not shielded by any structure. A minimum of 1m (3ft.) from any vertical or inclined roof structure must be allowed for.
- 5.1.14 Where flue blocks are used, builders should ensure that no obstruction is created during erection. The installer should ensure that the connection flue does not project beyond the internal wall of the flue blocks and that there is provision for examination and servicing.

- 5.1.15 **Important:** Before installing the appliance, carry out a visual check of the flue system as directed in the relevant section of BS5440 Pt. 1, then check the flue performance as follows:-
- a. Close all doors and windows in the room in which the appliance is to be installed.
 - b. Introduce some heat into the flue, using a blow torch or other means.
 - c. Carry out a flow visualisation check with a smoke pellet at the intended position for the appliance. Ensure that there is discharge of smoke from the correct terminal only, and no spillage into the room. Smoke coming out of other than the correct terminal only, or a down draught or 'no flow' condition, indicates that the flue has failed the test, and the appliance shall not be connected until the defect has been found and rectified, and the test satisfactorily completed.

5.2 ELECTRICAL

5.2.1 Mains.

- a. The heater is supplied with mains cable (PVC sheathed, heat resisting to 85°C), 3-core Brown-Blue-Green/Yellow, 6A, 0.75mm²), connected to a terminal block and exiting through the heater at the right hand top. The cable is suitable for a 230V 50Hz supply and shall be connected to the fixed wiring using a double pole switched, fused spur, incorporating a protective earth link. The fuse fitted shall be rated 5A to BS 1362 Connections shall be in accordance with the current edition of I.E.E Regulations BS 7671.
- b. Fan Delay Controls and Limit Switch are not adjustable and are set as follows:
 - i. Fan Delay Control closes at 54°C±4.5°C; opens at 40°C±3°C.
 - ii. Limit Switch opens at 80°C; closes at 60°C.
- c. A 24V room thermostat (not supplied), that complies with BS 800 BS 3955 and BS 4201 is essential to ensure close control of comfort conditions. An anticipator is located within the thermostat and is graded in amps. The anticipator should be checked and adjusted to 0.2A.

5.2.2 Room Thermostat and its location.

- a. The Room Thermostat should be located where there is free air circulation approx. 1.5m (5ft) from the floor.
- b. Avoid the following locations:-
 - i. In a room where temperature is greatly affected by the sun or any other heat source, e.g. radiant fire, wall light fittings or TV set.
 - ii. Near an outside door or windows, or on an outside wall.
 - iii. Where affected by warm air ducts, diffusers, waste pipes or the heater itself.
 - iv. Where subject to vibration.
- c. Connect Room thermostat wires to control panel terminals '7' and '8' (see Fig. 6 or 7).

5.3 GAS (See BS5864 and BS 6891)

- 5.3.1 An independent gas supply pipe from the meter is to be preferred wherever possible. When this is not possible, the pipe must be capable of taking the complete input of the heater and all other gas appliances being served by this same pipe. This supply should be suitably sized to conform to British Standards requirements of no more than 2.5 mbar (0.4in wg) pressure drop (See table of discharge in BS 5482 Part 1.).
- 5.3.2 The 1/2in union gas cock (supplied) must be fitted to the gas inlet of the heater for easy isolation during servicing. The gas pipe should be so fitted and installed as to be durable, substantial and gas tight. To assist in determining where a gas connection may not be tight, a leak detection fluid should be applied around the connection. Under no circumstances should a flame be used to locate a gas leak. Gas entry to the air heater is through either side to a Rc1/2 (1/2in BSP. external [taper] thread).

6. COMMISSIONING

6.1 PREPARATION:

- 6.1.1 Ensure that:
- a. Gas and Electrical supplies are **OFF**.
 - b. Filter, fan and fan compartments are free from obstructions.
 - c. All registers or grilles are open and conform to design specifications.
 - d. Return, relief and ventilation air installations are adequate.

6.2 SYSTEM BALANCING:

6.2.1 Set the Air Heater electrical supply **ON**.

6.2.2 Set the SUMMER AIRFLOW switch to '1'.

6.2.3 Balance the system to provide the required volume proportions at the warm air outlets.

Note: If the system includes ceiling diffusers, the air through these should be NOT LESS THAN 1.5m/s (300ft/min), except for very small rooms, (i.e. bathrooms etc.). Outlet faces may require partial blanking in order to achieve this.

6.2.4 Set the SUMMER AIRFLOW switch to '0'.

6.3 IGNITION OF PILOT AND MAIN BURNERS:

WARNING: If the pilot light is extinguished either intentionally or unintentionally, no attempt should be made to relight the gas for a minimum of 3 minutes. Ensure that the electrical supply, Time Control and Selector switches are set to '**OFF**'.

6.3.1 Set the room thermostat to its lowest setting.

6.3.2 On the Multifunctional Control, remove the Inlet Pressure test point cover, and fit a pressure test gauge (refer fig. 4).

6.3.3 Turn the heater Gas supply **ON**, test for gas soundness and purge the whole gas pipe as described in BS 5482 Part 1.

6.3.4 Referring to Fig. 4, press and hold the OPERATING CONTROL, and whilst observing the Pilot Burner, repeatedly press the Piezo igniter button until the Pilot Burner ignites.

6.3.5 After 20 seconds release the OPERATING CONTROL and let it spring out; ensure that the Pilot Burner remains alight. If the Pilot Burner extinguishes, rotate the OPERATING CONTROL clockwise to the '●' position and ensure that the OPERATING CONTROL is fully reset. Wait three minutes and repeat steps 6.2.4 and 6.2.5 until the Pilot burner remains alight.

6.3.6 With the Pilot burner lit, depress the OPERATING CONTROL and turn it to the position indicated by the flame symbol.

6.3.7 Ensure that the pilot flame envelops thermocouple tip (refer Fig. 3).

6.3.8 Set the Heater Electricity supply **ON**.

6.3.9 Set the Time control to the required Heating On periods.

6.3.10 Set the Selector switch to 'TIMED'.

6.3.11 Set the room thermostat to **MAXIMUM**.

6.3.12 Ensure that the main burner has now ignited.

6.3.13 Test for gas leakage at the supply, Multifunctional control, Pilot and Main burners using proprietary detection fluid, sealing any leaks found.

6.3.14 Allow heater to operate for a minimum of 15 minutes to ensure stability.

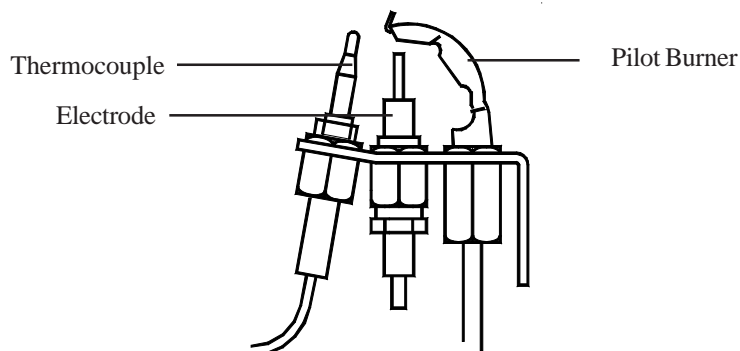

Fig. 3
PILOT BURNER ASSEMBLY

6.4 MAIN BURNER PRESSURE TEST AND TEMPERATURE RISE CHECK:

6.4.1 Referring to Table 4 and Fig. 4 below, ensure that the pressure test gauge indicates correct pressure, adjusting the supply pressure if required.

a. At the Multifunctional control:

- i. Remove the Burner Pressure Adjuster cover.
- ii. Set the Burner Pressure Adjuster to provide a pressure test gauge indication for the correct burner pressure as detailed in Table 4.
- iii. Refit the Burner Pressure Adjuster cover.

6.4.2 Check that the temperature rise across heater is between 45°C - 55°C, setting the fan speed accordingly by alteration of the voltage selection at the tap changer on the control panel, (decrease voltage to decrease fan speed thus increase temperature).

Note: Tapping 1 = 150V, Tapping 2 = 170V, Tapping 3 = 190V, Tapping 4 = 210v and Tapping 5 = 230V.

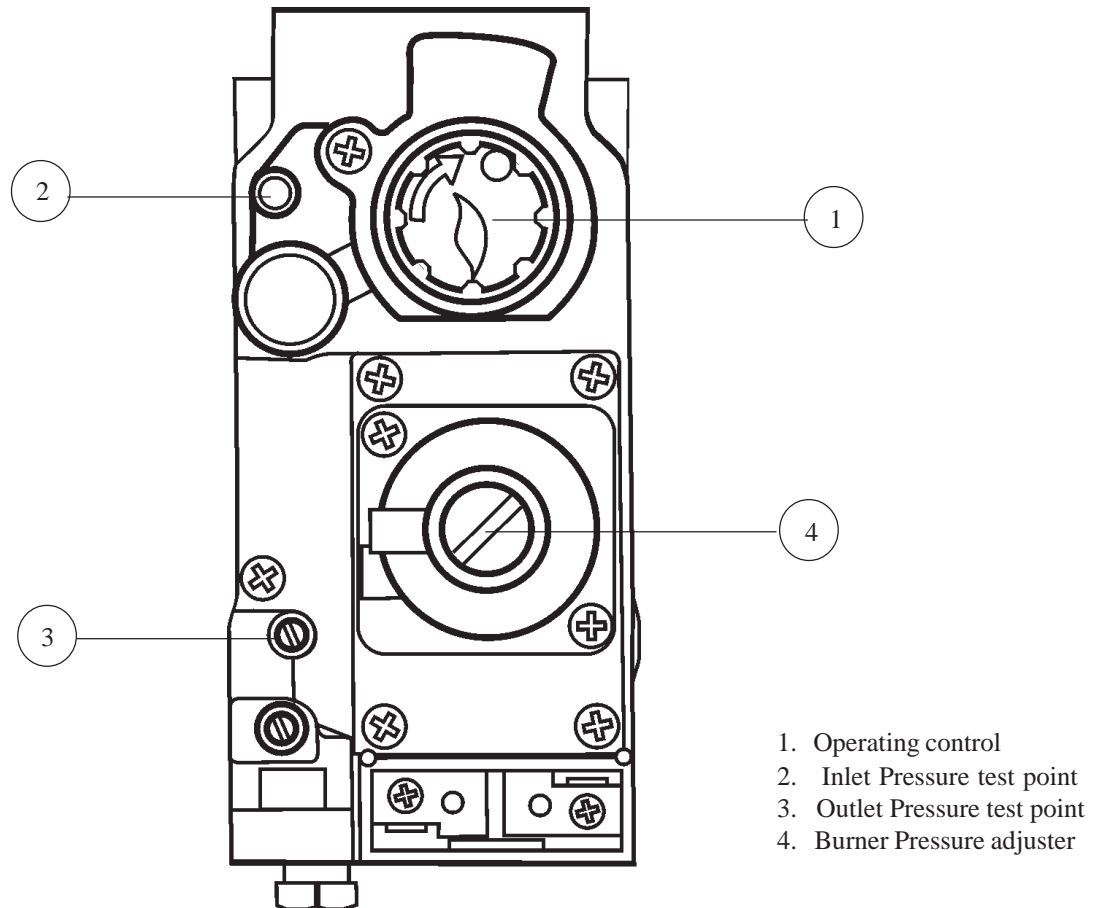

Fig. 4
MULTIFUNCTIONAL CONTROL

5 EXTINGUISHING OF PILOT AND MAIN BURNERS:

6.5.1 On the Multifunctional Control, rotate the OPERATING CONTROL clockwise to the '●' position and ensure that the OPERATING CONTROL fully resets, and both Pilot and Main Burners are extinguished.

6.5.2 On the Multifunctional Control, remove the pressure test gauge and secure the Pressure test point screw.

6.6 AUTOMATIC CONTROLS CHECK

6.6.1 Ignite the Pilot burner.

6.6.2 Set the TIME CONTROL to 'ON'.

6.6.3 Set the Room Thermostat slowly clockwise until the Main Burner ignites.

6.6.4 Ensure that the fan starts to operate after a short period.

6.6.5 When the temperature reaches the control setting, check that the Main Burner extinguishes followed by the fan switching off after a short period.

6.6.6 When the temperature falls below the control setting, ensure that the Main Burner re-ignites followed by fan operation.

6.8 **SAFETY CHECKS:**

6.8.1 Check for gas soundness within the appliance.

6.8.2 **Spillage test:** Carry out a full spillage test as follows, and ensure that the flue operates effectively with all doors closed and any extractor fans in operation.

NOTE: If an extractor fan is situated in an adjoining or adjacent room, carry out the spillage test with the interconnecting doors open.

If the draught diverter is accessible:

- a. Introduce smoke into the draught diverter adjacent to an exit from the heat exchanger, by means of a smoke match or puffer.
- b. Ensure that there is no spillage present (indicated by displacement of smoke downwards and out of the draught diverter).

If the Draught Diverter is not accessible:

- a. Introduce smoke, by means of **part** of a smoke pellet on a non-combustible support, into the heat exchanger.
- b. Extinguish the Main and Pilot burners.
- c. Ensure that there is no spillage evident by visually observing the draught diverter location on the air heater.
- d. If spillage is evident, further investigation and rectification is required before re-testing the appliance.
- e. **Repeat spillage tests but with the fan running, or Summer Airflow switch set to ON.**

WARNING: The appliance shall not be left connected to the gas supply unless it has successfully passed the above spillage test.

- 6.8.3 Turn OFF the gas supply at the service cock and ensure that the Multifunctional Control fail-safe operates within 60 secs (indicated by loud click from Multifunctional Control).
- 6.8.4 Turn gas supply ON at service cock.
- 6.8.5 Switch the appliance electrical supply OFF.
- 6.8.6 Disconnect the Air Circulation Fan at the flying lead socket.
- 6.8.7 Switch the appliance electrical supply ON.
- 6.8.8 Ignite the Pilot and Main Burners as detailed in 6.3.1 to 6.3.5.
- 6.8.9 Ensure that the Limit Switch operates, indicated by the main burner extinguishing, within 120 and 180 seconds.
- 6.8.10 Switch the appliance electrical supply OFF.
- 6.8.11 Reconnect the Air Circulation Fan.
- 6.8.12 Switch the appliance electrical supply ON.
- 6.8.13 Ensure that the Main Burner re-ignites when the appliance temperature reduces, (note: with the Air Circulation Fan disconnected, there may be some delay before the Main Burner re-ignites).

	kW	MJ/h	Btu/h
INPUT	11.1	40.0	38,000
OUTPUT	8.30	29.88	28,320
Gas rate Propane G31	0.418 m ³ /h (14.77 ft ³ /h)		
Burner setting pressure (hot)	33 mbar (13.2 in wg)		
Main Injector	Bray 1.78mm		

Table 4
Main Burner Pressure Settings

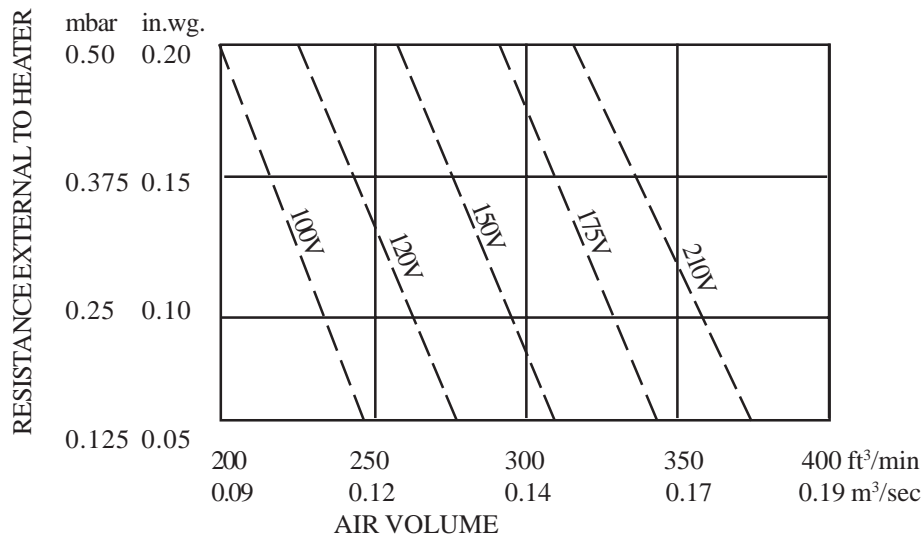

Table 5
Fan Performance Curve

7. INSTRUCTIONS FOR USERS

- 7.1 If the building is unoccupied, ensure that the Instructions for User are left taped to the air heater for the User, and Installation Instructions are left at or near the air heater for use on future service calls.
- 7.2 If the building is occupied, hand the User Instructions over and ensure the User understands:
 - 7.2.1 How to ignite the pilot and burner.
 - 7.2.2 How to operate the room thermostat, time and heater ON/OFF switch and summer air circulation switch, and that the time control must be reset following a power failure.
 - 7.2.3 How to extinguish the pilot and main burner at the Multifunctional control, and switch off electrical supply to the heater.
 - 7.2.4 How to remove, clean and refit the air filter and at what intervals (i.e. fortnightly, or for new houses, weekly).
 - 7.2.5 How to control the heating system by opening and closing warm air outlets.
 - 7.2.6 How to obtain summer air circulation.
 - 7.2.7 That the air grilles on the heater or heater compartment; grilles and ventilators in the walls, windows or doors of the building must not be obstructed.
 - 7.2.8 That the heater must be serviced at least once a year by a competent person to ensure efficient and safe operation.
 - 7.2.9 That the red instructions for safe use have been pointed out and understood.
 - 7.2.10 That expert help must be obtained if persistent failure of the pilot burner occurs.

8. MAINTENANCE

IMPORTANT: Ensure gas and electricity supplies are isolated before commencing any maintenance or replacement of components. After completion of any maintenance, always test for gas soundness and carry out a complete functional test of the appliance in accordance with Commissioning Instructions at Sect 6.1 to 6.8 inclusive.

8.1 ROUTINE MAINTENANCE:

- 8.1.1 Operate the appliance and check for the correct function of the burner and controls.
- 8.1.2 Turn OFF the gas and electrical supplies to the appliance.
- 8.1.3 Remove the air heater front panel.
- 8.1.4 Remove and check the return air filter/cleaner for cleanliness, remove and clean the Air Circulation fan as detailed in para 8.7.
- 8.1.5 Remove the Burner and Controls Assembly as detailed in para 8.2. Inspect and clean the main burner and injector as necessary. Examine the main burner for cracks, including hairline cracks, exchanging the burner as necessary.
- 8.1.6 Inspect and clear the pilot burner orifice.
- 8.1.7 Clean the heat exchanger flueways by thoroughly brushing from above and below.
- 8.1.8 By viewing through the Fan Aperture, and using a torch or similar, examine the heat exchanger externally for signs of cracks or holes, particularly around welded joints.

- 8.1.9 Using a torch or similar, introduce a light source into the heat exchanger burner aperture and upper access port, and again examine the heat exchanger for signs of cracks or holes, particularly around welded joints, whilst again viewing through the Fan Aperture.
- 8.1.10 Refit the Air Circulation fan, Burner and Controls Assembly, and air filter/air cleaner.
- 8.1.11 Light the appliance and note the main burner flame profile. If the flame profile is affected when the Air Circulation fan switches on, check for any air leaks between the air heater and the base plenum, paying particular attention to heaters with rear draught diverters. Rectify any air leaks before continuing with this procedure.
- 8.1.12 Allow the air heater to operate for approximately 15 minutes to ensure stability, and with the main burner lit, ensure that the operation of Air Circulation fan does not affect the main burner flame profile.
- 8.2 **BURNER AND CONTROL ASSEMBLY REMOVAL:**
- 8.2.1 Ensure that the Gas and Electrical supplies are switched OFF
- 8.2.2 Remove the appliance louvre door.
- 8.2.3 Disconnect the igniter at the Piezo unit.
- 8.2.4 Disconnect the Multifunctional Control electrical connections.
- 8.2.5 Disconnect the gas supply by breaking the union at the input side of the Multifunctional Control, and water heater union (if applicable).
- 8.2.6 Whilst supporting the Burner and Control Assembly, remove 3 x Burner Assembly fixing screws and withdraw the Burner and Control Assembly
- 8.2.7 Refit the Burner and Control Assembly in reverse order.
- 8.3 **BURNER AND CONTROL ASSEMBLY CLEANING:**
- 8.3.1 Remove the Burner and Controls Assembly as detailed in 8.2.
- 8.3.2 Disconnect the Pilot Feed Pipe and Thermocouple from the Multifunctional Control.
- 8.3.3 Release the single screw, nut and washer securing the Pilot Assembly to the Burner and Controls Assembly, and remove the Pilot Assembly.
- 8.3.4 Release the 2 screws, nuts and washers securing the Main Burner to the mounting bracket, and remove the Main Burner.
- 8.3.5 Clean burner thoroughly both inside and out with a soft brush. **DO NOT ENLARGE, DISTORT OR DAMAGE BURNER HOLES.**
- 8.3.6 Reassemble in reverse order.
- 8.4 **PILOT BURNER, THERMOCOUPLE AND ELECTRODE, REMOVAL AND REPLACEMENT:**
- 8.4.1 Remove the Burner and Controls Assembly as detailed in 8.2
- 8.4.2 Disconnect the Igniter lead from the Electrode.
- 8.4.3 Disconnect the Thermocouple from the Multifunctional Control, taking care to avoid damage to the thermocouple capillary.
- 8.4.4 Release the Pilot Feed Pipe from the Multifunctional Control.
- 8.4.5 Release the single screw, nut and washer securing the Pilot Assembly to the Burner and Controls Assembly, and remove the Pilot Assembly.
- 8.4.6 Release the Thermocouple securing nut from the Pilot Burner Assembly and withdraw the Thermocouple, taking care to avoid damage to the Thermocouple capillary.
- 8.4.7 Release the Electrode securing nut from the Pilot Burner Assembly and withdraw the Electrode.
- 8.4.8 Release the Pilot Feed Pipe securing nut from the Pilot Burner Assembly and withdraw the Pilot Feed Pipe and Pilot Injector from the Pilot Burner assembly, and disconnect the Pilot Injector from Pilot Feed Pipe hook.
- 8.4.9 Release the 2 screws securing the Pilot Burner Bracket to the Pilot Mounting bracket, and remove the Pilot Burner Bracket.
- 8.4.10 Refitting or replacement is in reverse order.
- NOTE: When refitting or replacing the Thermocouple, tighten only to FINGER TIGHT + 1 FLAT.**

8.5 **MULTIFUNCTIONAL CONTROL REMOVAL:**

- 8.5.1 Remove the Burner and Controls Assembly as detailed in 8.2
- 8.5.2 Disconnect the Thermocouple at the Multifunctional Control, avoiding damage to the capillary.
- 8.5.3 Disconnect the Pilot Feed Pipe from the Multifunctional Control.
- 8.5.4 Disconnect the Multifunctional Control input and output supply feeds.
- 8.5.5 Refitting or replacement is in reverse order.

NOTE: When refitting or replacing the Multifunctional Control, the 'O' ring seal is to be replaced.

8.6 **PIEZO UNIT REMOVAL:**

- 8.6.1 Disconnect the 2 conductors from Piezo unit.
- 8.6.2 Release the retaining nut and remove the Piezo unit from its mounting bracket.
- 8.6.3 Refitting or replacement is in reverse order.

8.7 **AIR CIRCULATING FAN, REMOVAL AND CLEANING:**

- 8.7.1 Ensure that the electrical supply is isolated.
- 8.7.2 Remove the appliance louvre door, release the 2 x securing screws and hinge down the fan chamber door.
- 8.7.3 Disconnect the fan flying leads from the Fan Assembly.
- 8.7.4 Release the Fan Assembly securing screw and withdraw the Fan Assembly from the Heater cabinet, avoiding damage to the fan blades.
- 8.7.5 Remove all dust from both the impeller and motor, taking care to not disturb the balance of the fan.
- 8.7.6 Refitting or replacement is in reverse order.

8.8 **ELECTRICAL ASSEMBLY REMOVAL:**

- 8.8.1 Ensure that the electrical supply is isolated.
- 8.8.2 Remove the appliance louvre door, release the 2 x securing screws and hinge down the fan chamber door.
- 8.8.3 Disconnect the following:
 - a. Air circulation fan flying leads from the Fan assembly,
 - b. 230V mains 'L', 'N' and 'E' from connection block terminals '1' and '2', and **Earth stud** respectively,
 - c. Room thermostat connections from connection block terminals '7' and '8',
 - d. Limit Switch from connection block terminals '13' and '14',
 - e. Fan Delay Control from connection block terminals '18' and '17',
 - f. Multifunctional Control from connection block terminals '16 (N) and '15' (L),
 - g. Water heater from connection block terminals '10' (L) and '9' (N),
 - h. Water Pump from connection block terminals '12' (L) and '11' (N),
 - i. Cleanflow from connection block terminals '19' (24V) and '20' (0V),
 - j. Earth lead from the fan chamber floor,

8.8.4 Disconnect 2 x Spillage monitoring device connections from the terminal block on the fan compartment diaphragm.

8.8.5 Release the 2 x hinge pins and withdraw the Electrical Assembly, releasing wiring from cable clamps and grommets as required..

8.8.6 Refitting or replacement is in reverse order.

8.9 **TRANSFORMER REMOVAL:**

- 8.9.1 Ensure that the electrical supply is isolated.
- 8.9.2 Remove the appliance louvre door, release the 2 x securing screws and hinge down the fan chamber door.
- 8.9.3 Disconnect the conductors from the large Transformer.
- 8.9.4 Release 2 x screws and nuts securing Transformer to Electrical assembly, and remove Transformer..
- 8.9.5 Refitting or replacement is in reverse order.

8.10 **TIME CONTROL and SWITCH REMOVAL:**

8.10.1 Ensure that the electrical supply is isolated.

8.10.2 Remove the appliance louvre door, release the 2 x securing screws and hinge down the fan chamber door.

Time Control removal:

8.10.3 Disconnect conductors 'C1', 'C2', 'C3' and 'C5' from the Time control.

8.10.4 Release the 2 x fixing screws, and withdraw the Time control.

8.10.5 Refitting or replacement is in reverse order.

8.10.6 Set the Time Control to the required ON and OFF times.

8.10.7 Set the Time Control to the correct time.

Switch removal:

8.10.8 Disconnect the conductors from the switch terminals.

8.10.9 Depress the retaining clips and press the switch out of the fascia panel.

8.10.10 Refitting or replacement is in reverse order.

WARNING: The fascia panel is held in place by push fit retainers which must be removed with caution to avoid causing damage to the support pins. Removal of the fascia is not advised unless it is intended to be replaced.

8.11 **FAN DELAY CONTROL/LIMIT SWITCH REMOVAL:**

8.11.1 Ensure that the electrical supply is isolated.

8.11.2 Remove the appliance louvre door, release the 2 x securing screws and hinge down the fan chamber door.

8.11.3 Disconnect the following at the Electrical panel:

- a. Limit Switch from connection block terminals '13' and '14',
- b. Fan Delay Control from connection block terminals '18' and '17',
- c. Earth connection from common earth stud.

8.11.4 Release 2 x 4mm screws securing Limit Switch mounting plate, and withdraw the control from the appliance by drawing the conductors through the grommet in the fan chamber floor.

8.11.5 Refitting or replacement is in reverse order.

8.12 **SPILLAGE MONITORING DEVICE (TTB) REMOVAL:**

8.12.1 Ensure that the electrical supply is isolated.

8.12.2 Remove the appliance louvre door, release the 2 x securing screws and hinge down the fan chamber door.

8.12.3 Disconnect the TTB from its conductors.

8.12.4 Release 2 x screws securing the TTB Bracket to the fan chamber floor, and withdraw TTB Bracket.

8.12.5 Refitting or replacement is in reverse order.

8.13 **HEAT EXCHANGER ACCESS:**

8.13.1 Ensure that the electrical supply is isolated.

8.13.2 Remove the appliance louvre door.

8.13.3 Remove the Burner and Controls Assembly as detailed in sect 8.2.

8.13.4 Release the 4 screws securing the combustion chamber heat shield, and withdraw the heat shield.

8.13.5 Release the 4 screws securing the top access cover plate, and withdraw the cover plate and gasket

8.13.6 Release the 4 screws securing the heat exchanger top sealing plate, and withdraw the sealing plate and gasket.

8.13.7 Reassembly is in reverse order.

NOTE: When reassembling, ensure that the gaskets are soundly sealed, and fully re-commission the heater.

- 9.1 **IMPORTANT:** If an electrical defect occurs after installation of the appliance; preliminary earth continuity, polarity, and resistance to earth checks should be carried out with a multimeter. On completion of any maintenance/fault-finding task that has required the breaking and remaking of electrical connections, then checks of continuity, polarity, and resistance to earth must be repeated.
- 9.2 **WARNING:** When purging or checking gas supplies, ensure that the ventilation to the room or cupboard is adequate, and that all naked lights are extinguished.

SYMPTOM	POSSIBLE CAUSE	REMEDY
a. Pilot will not light.	i. No gas supply to heater. ii. Gas supply pipe not purged. iii. Pilot orifice restricted. iv. Piezo system faulty. v. Excessive gas supply pressure.	Check for gas at inlet pressure test point on Multifunctional Control. Purge gas supply pipe in accordance with BS 6891. Clear pilot orifice or replace pilot injector. Check igniter, lead, and electrode. Check that mains gas pressure is 37mbar, and reduce if necessary.
b. Pilot lights but goes out on releasing START button during initial light-up, or after normal operation.	i. Connection between thermocouple and Multifunctional Control not secure. ii. Faulty Multifunctional Control. iii. Faulty Thermocouple.	Check connection is secure. Replace Multifunctional Control. Replace Thermocouple.
c. Main burner operating intermittently with fan running.	i. Gas rate or burner pressure setting high. ii. Temperature rise excessive. iii. Air filter or return air path restricted. iv. Excessive number of outlets closed. v. Spillage of flue gases. vi. Spillage monitor device (TTB) faulty.	Check gas rate and burner pressure setting. Adjust fan speed or gas rate accordingly. Check filter is clean and air path is clear. Open additional outlets. Carry out spillage test and rectify. Replace Spillage device (TTB)
d. Pilot alight but main burner not igniting.	i. Mains electrical supply not connected to heater. ii. Controls not demanding heat iii. T3.15A fuse failed. iv. Loose connection to room thermostat, Limit Switch, gas control lead, time control, or transformer. v. 230V/24V transformer failure. vi. Faulty relay module vii. Multifunctional Control faulty. viii. Limit Switch faulty. ix. Room thermostat or external wiring faulty. x. Spillage device faulty circuit.	Check mains supply. Check that time control and room thermostat are operating correctly. Replace. If failure occurs again, check wiring for short circuits. Check connections. Check 24V side with test meter, if voltage missing, replace transformer. Check 230V at white wire from switch S5 Replace Multifunctional Control. Short circuit control and replace Fan Delay/ Limit control if necessary. Fit temporary loop in heater thermostat socket. If heater ignites, external circuit or room thermostat is faulty. Check Spillage device and wiring for open

e.	Main burner lights but fan fails to run after approx. 3 min.	<ul style="list-style-type: none"> i. Loose electrical connection at fan control. ii. Fan delay control faulty. iii. Faulty fan assembly. iv. Burner pressure setting incorrect. 	<p>Check connections.</p> <p>Replace Fan Delay/Limit Switch.</p> <p>Replace, taking care not to damage impeller.</p> <p>Adjust pressure as necessary.</p>
g.	Main burner operating with intermittent fan operation.	<ul style="list-style-type: none"> i. Gas rate or burner pressure setting too low. ii. Fan delay control faulty 	<p>Check gas rate and burner pressure setting.</p> <p>Replace Fan Delay/Limit control.</p>
h.	Noisy operation.	<ul style="list-style-type: none"> i. Gas pressure too high. ii. Noisy fan motor. iii. Fan speed setting too high. 	<p>Check burner pressure setting.</p> <p>Replace fan assembly.</p> <p>Adjust fan speed.</p>
i.	Fan runs for excessive period or operates intermittently after main burner shuts down.	<ul style="list-style-type: none"> i. Fan delay control faulty. 	<p>Replace Fan Delay/Limit control.</p>

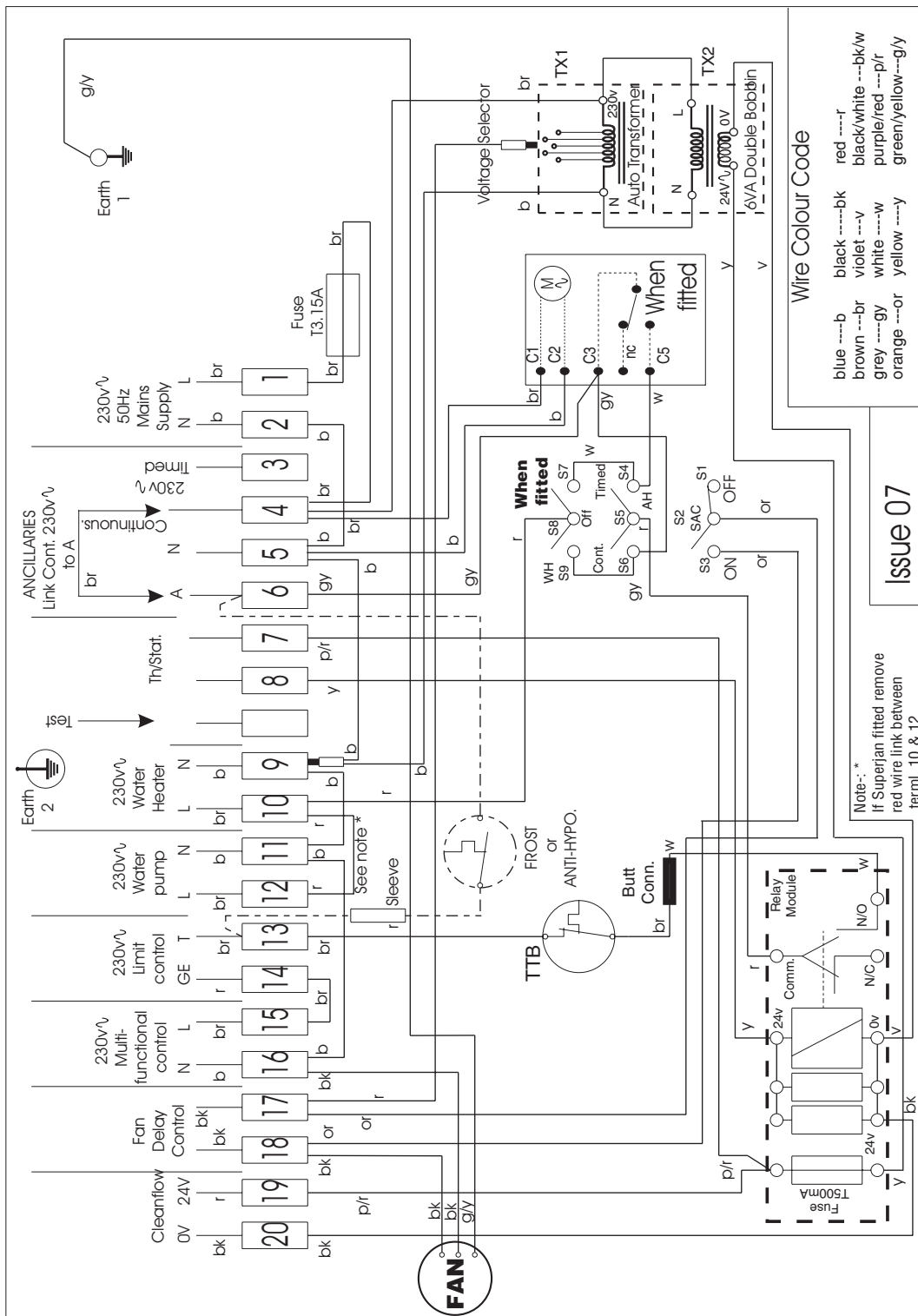

Fig. 5, CIRCUIT DIAGRAM

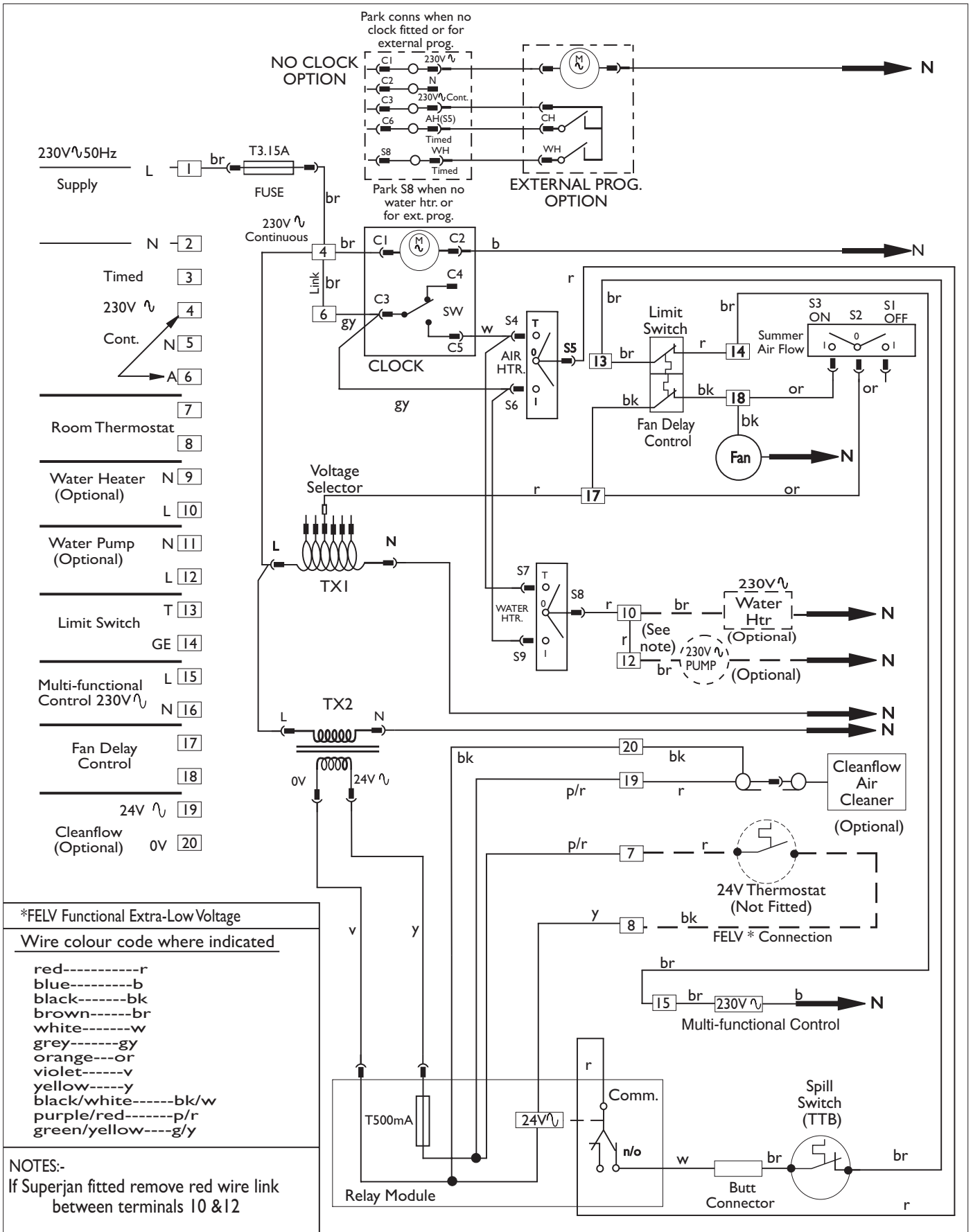
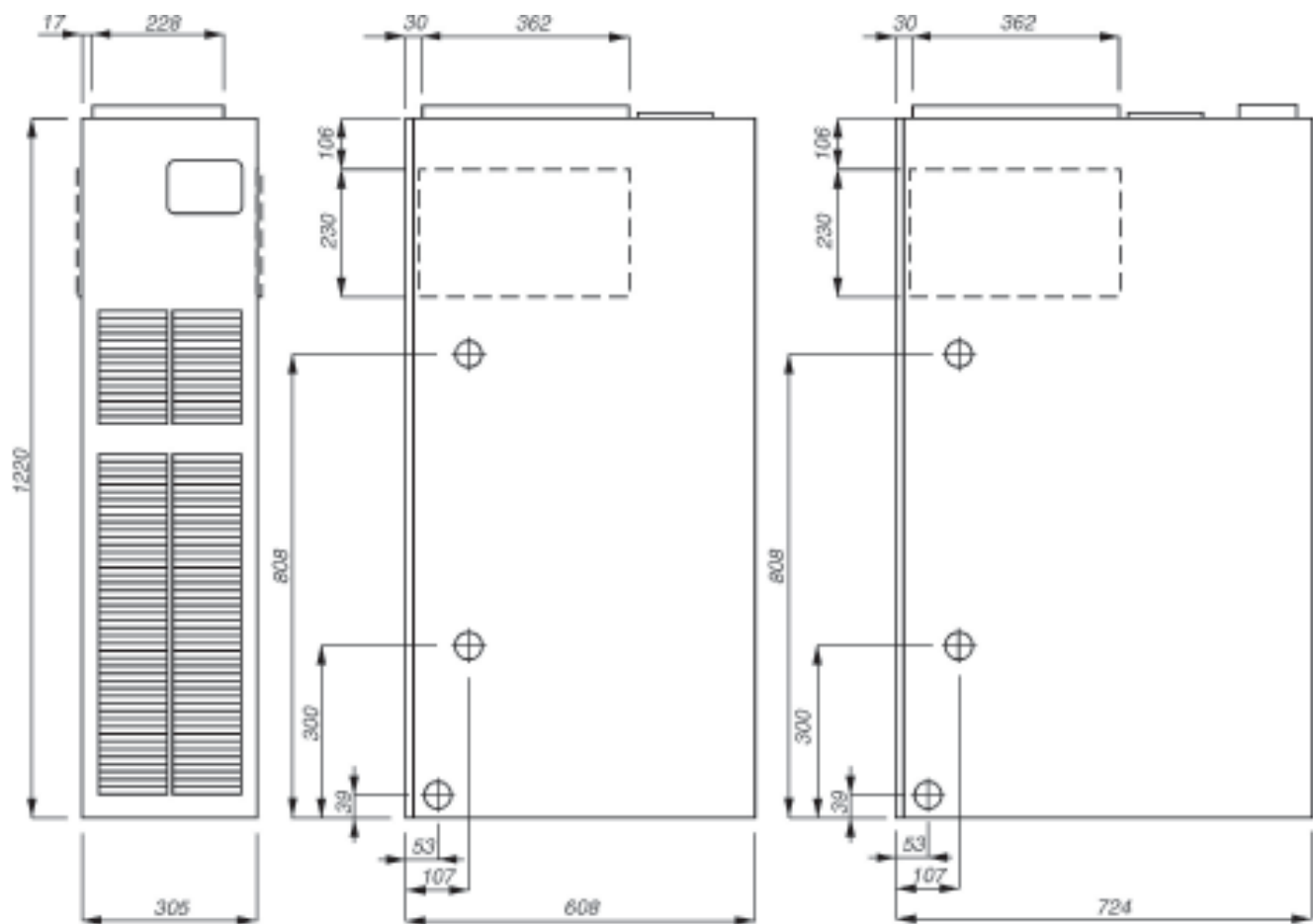

Fig. 6, FUNCTIONAL DIAGRAM



HI-SPEC J32 & J32R
FRONT VIEW

HI-SPEC J32
SIDE VIEW

HI-SPEC J32R
SIDE VIEW

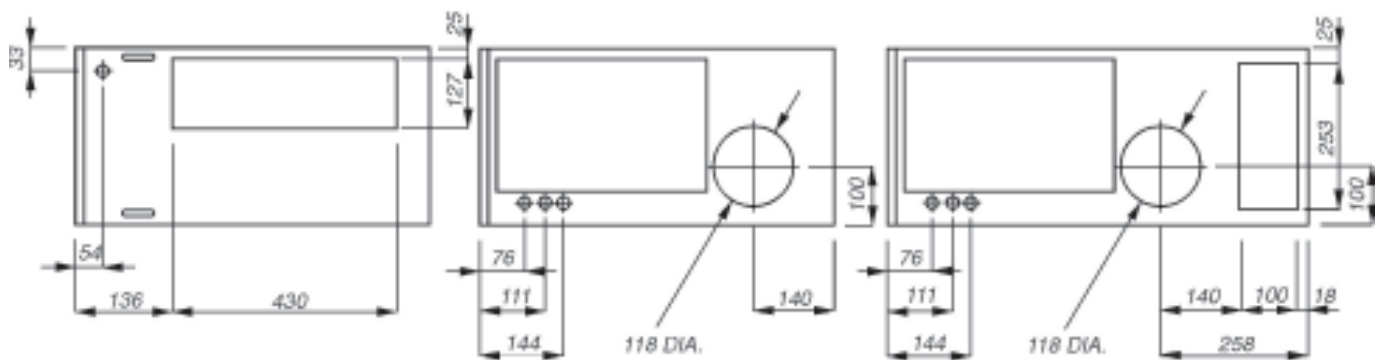

HI-SPEC J32 & J32R
BASE VIEW

HI-SPEC J32
PLAN VIEW

HI-SPEC J32R
PLAN VIEW

Fig. 7, PRINCIPAL DIMENSIONS (mm)

10.

SHORT LIST OF SPARES

HI-SPEC J32P and HI-SPEC J32RP

KEY	G.C No	MFR'S No	DESCRIPTION	QTY
1	245 501	1000-0500370	Fan Assembly	1
2	H26-712	1000-0709640	Multifunctional Control Honeywell V8600C 1129	1
		BOS 02397/2	Pilot Burner	1
		1000-0701440	Pilot Injector (No 19)	1
		1000-0704730	Pilot Feed Pipe	1
	390 210	BOS 01970	Igniter Electrode	1
		BOS 02394	Igniter Lead	1
	381 626	1000-0704830	Thermocouple	1
4	378 466	BOS 02031	Time Control	1
5		1000-0708020	Burner Bar Assembly	1
6		1000-0708040	Main Injector (Bray 1.78mm)	1
7	395 945	1000-0700570	Piezo Unit (High Energy)	1
8	245 509	1000-0513820	Fuse T3.15A anti-surge	1
13	386 634	1000-0503730	Spillage Monitor Device (TTB)	1
14		J304-0511000	Electrical Panel	1
15	245 520	1000-0516125	Fan Delay/Limit Control	1
16		1000-0515190	Transformer Fan Speed	1
17	245 525	1000-0515730	Transformer 24 volt	1
18	245 413	1000-0511760	Relay Module	1
19		J304-0769000	TTB Assembly (water heater)	1

Johnson and Starley prides itself on its ability to supply spare parts quickly and efficiently. If you have a problem in obtaining a spare part, please contact Johnson and Starley Spares Department at the address below.

Telephone: (01604) 762881

Fax: (01604) 767408

JOHNSON & STARLEY LTD.
Rhosili Road,
Brackmills,
Northampton NN4 7LZ